

TECHNICAL MANUAL

**OPERATOR'S, UNIT, DIRECT SUPPORT,
AND GENERAL SUPPORT MAINTENANCE
MANUAL**

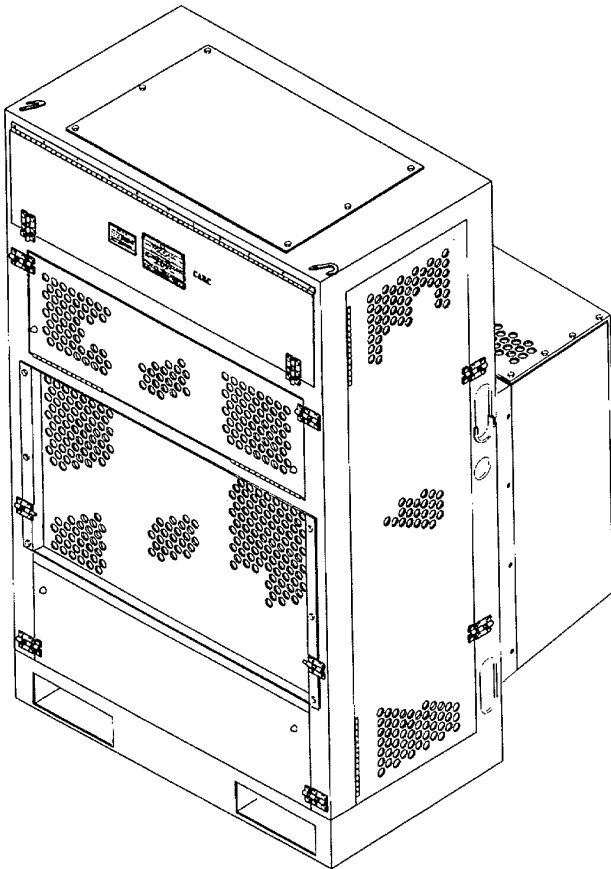

**REFRIGERATION UNIT, MECHANICAL,
5K BTU, ELECTRIC
MODEL F5000RE**

(4110-01-389-9180)

OPERATING INSTRUCTIONS	2-1
OPERATOR PREVENTIVE MAINTENANCE CHECKS AND SERVICES (PMCS)	2-6
UNIT MAINTENANCE INSTRUCTIONS	4-1
UNIT PREVENTIVE MAINTENANCE CHECKS AND SERVICES (PMCS)	4-10
UNIT TROUBLESHOOTING	4-24
DIRECT SUPPORT MAINTENANCE INSTRUCTIONS	5-1
GENERAL SUPPORT MAINTENANCE INSTRUCTIONS	6-1
MAINTENANCE ALLOCATION CHART	B-1

DISTRIBUTION STATEMENT A: Approved for public release, distribution is unlimited

**HEADQUARTERS, DEPARTMENT OF THE ARMY
23 MAY 1996**

WARNING

- High voltage and exposed rotating parts are contained in the refrigeration unit. Personal injury can result if access doors are open when power is connected.
- Dangerous chemical refrigerant under pressure is used in the refrigeration unit. Sudden and Irreversible tissue damage can result from contact with liquid refrigerant. When exposed to high heat or flame, irritating, toxic, and corrosive gases may be released. Wear gloves and a face protector or safety glasses in any situation where skin or eye contact with refrigerant is possible. Do not allow refrigerant to come in contact with high heat or flame. All refrigerant must be discharged from the system and the entire system must be purged with dry nitrogen before beginning any brazing operation.
- Do not attempt any disassembly of refrigerant system components with a refrigerant charge in the system. Refrigerant will be sprayed out dangerously.
- Never introduce high discharge pressure into a refrigerant cylinder. This can cause the cylinder to rupture and injure personnel.
- Never pressurize refrigerant lines with oxygen, mixture with oil could cause an explosion.
- Nitrogen is an inert gas that can cause suffocation and must be discharged in a well ventilated area.
- The pressure in a nitrogen cylinder can exceed 2000 psi. A nitrogen pressure regulator should be used at all times to avoid personal injury.
- Acetone and methyl-ethyl ketone (MEK) are flammable and their vapors can be explosive. Repeated or prolonged skin contact or inhalation of vapors can be toxic. Use in a well ventilated area, wear gloves, and keep away from sparks or flame.
- Solder, brazing alloys, and flux contain materials which are hazardous to health. Avoid breathing vapors or fumes from soldering or brazing operations. Perform operations only in well-ventilated areas. Wash hands with soap and water after handling solder, brazing alloys, or flux. Wear thermal gloves and protective goggles or face shield to protect against burns.
- Compressor lubricating oil used in this refrigeration system is caustic. Wear gloves and a face protector or safety glasses in any situation where skin or eye contact is possible. If oil does contact skin, wash with soap and water.

a/(b blank)

**OPERATOR'S, UNIT, DIRECT SUPPORT, AND
GENERAL SUPPORT MAINTENANCE MANUAL
FOR
REFRIGERATION UNIT, MECHANICAL,
5K BTU, ELECTRIC
MODEL F5000RE
4110-01-389-9180**

REPORTING ERRORS AND RECOMMENDING IMPROVEMENTS

You can help improve this manual. If you find any mistakes, or if you know of a way to improve these procedures, please let us know. Mail your letter or DA Form 2028 (Recommended Changes to Publications and Blank Forms), or DA Form 2028-2 located in the back of this manual directly to: Commander, US Army Aviation and Troop Command, ATTN: AMSAT-I-MP, 4300 Goodfellow Blvd., St. Louis, MO 63120-1798. You may also submit your recommended changes by E-mail directly to <mpmto/oavma28@st-louis-emh7.army.mil>. A reply will be furnished directly to you. Instructions for sending an electronic 2028 may be found at the back of this manual immediately preceding the hard copy 2028.

DISTRIBUTION STATEMENT A: Approved for public release, distribution is unlimited

TABLE OF CONTENTS

		Page
CHAPTER 1	INTRODUCTION.....	1-1
Section I	General Information.....	1-1
Section II	Equipment Description.....	1-3
Section III	Principles of Operation.....	1-6
CHAPTER 2	OPERATING INSTRUCTIONS	2-1
Section I	Description and Use of Operator's Controls and Indicators.....	2-1
Section II	Preventive Maintenance Checks and Services (PMCS)	2-6
Section III	Operation Under Usual Conditions.....	2-17
Section IV	Operation Under Unusual Conditions.....	2-22

TABLE OF CONTENTS - Continued

CHAPTER 3	OPERATOR MAINTENANCE INSTRUCTIONS.....	3-1
Section I	Lubrication	3-1
Section II	Troubleshooting Procedures	3-2
Section III	Operator's Maintenance Procedures	3-5
CHAPTER 4	UNIT MAINTENANCE INSTRUCTIONS	4-1
Section I	Repair Parts, Tools, Special Tools, Test, Measurement, and Diagnostic Equipment (TMDE), and Support Equipment	4-1
Section II	Service Upon Receipt	4-1
Section III	Unit Preventive Maintenance Checks and Services (PMCS)	4-10
Section IV	Unit Troubleshooting Instructions	4-24
Section V	Unit Maintenance Procedures	4-29
Section VI	Preparation for Storage or Shipment.....	4-113
CHAPTER 5	DIRECT SUPPORT MAINTENANCE INSTRUCTIONS	5-1
Section I	Direct Support Troubleshooting Instructions	5-1
Section II	Direct Support Maintenance Procedures	5-3
CHAPTER 6	GENERAL SUPPORT MAINTENANCE INSTRUCTIONS	6-1
APPENDIX A	REFERENCES	A-1
APPENDIX B	MAINTENANCE ALLOCATION CHART	B-1
Section I	Introduction.....	B-1
Section II	Maintenance Allocation Chart for Refrigeration Unit.....	B-5
Section III	Tool and Test Equipment Requirements for Refrigeration Unit.....	B-9
Section IV	Remarks for Refrigeration Unit.....	B-9
APPENDIX C	COMPONENTS OF END ITEM (COEI) AND BASIC ISSUE ITEMS LIST	C-1
Section I	Introduction.....	C-1
Section II	Components of End Item	C-1
Section III	Basic Issue Items List	C-2

TABLE OF CONTENTS - Continued

APPENDIX D ADDITIONAL AUTHORIZATION LISTD-1

APPENDIX E EXPENDABLE AND DURABLE ITEMS LISTE-1

 Section I IntroductionE-1

 Section II Expendable and Durable Items ListE-2

APPENDIX F ILLUSTRATED LIST OF MANUFACTURED ITEMSF-1

 Section I F-1

 Section II F-1

APPENDIX G MANDATORY REPLACEMENT PARTS.....G-1

ALPHABETICAL INDEX..... Index-1

LIST OF ILLUSTRATIONS

Figure	Title	Page
1-0	Refrigeration Unit	1-0
1-1	Major Components	1-4
1-2	Electrical System	1-6
1-3	Electrical Schematic.....	1-7
1-4	Electrical Wiring Diagram (Sheet 1 of 2)	1-8
1-4	Electrical Wiring Diagram (Sheet 2 of 2)	1-9
1-5	Refrigeration System.....	1-10
1-6	Refrigeration Schematic.....	1-11
1-7	Air Flow.....	1-12
2-1	Operating Controls and Indicators	2-3
2-2	Fault Controls and Indicators	2-5
2-3	Operator's PMCS Routing Diagram	2-7
2-4	Operating Controls and Indicators	2-18
2-5	Decals and Instruction Plates (Sheet 1 of 2)	2-20
2-5	Decals and Instruction Plates (Sheet 2 of 2)	2-21
4-1	Wall Opening Dimensions	4-2
4-2	Installation.....	4-3
4-3	Input Power Connection	4-5
4-4	Refrigeration Valve Settings for Normal Operation	4-6
4-5	Compressor Mount.....	4-7
4-6	Preliminary Adjustment	4-8
4-7	Lubrication	4-11
4-8	Barrel Bolts	4-30
4-9	Top Panel	4-31
4-10	Access Panel	4-32
4-11	Cover Panel (Coil Guard Rear)	4-33
4-12	Coil Guard Front Panel	4-34
4-13	Unit Mounting Bolt Assembly.....	4-36
4-14	Control Box Assembly.....	4-38
4-15	Wires, Cables and Harnesses	4-41
4-16	Circuit Breaker	4-47
4-17	Resistor R1 Assembly	4-49
4-18	Lamp DS1 Assembly.....	4-51
4-19	Fuses.....	4-53
4-20	Motor Starter	4-55
4-21	Contractor	4-58
4-22	Control Relays.....	4-61
4-23	Hourmeter.....	4-63
4-24	Toggle Switch	4-65
4-25	Repeat Cycle Timer	4-67
4-26	Remote Bulb Thermostat (Temperature Control).....	4-70
4-27	Terminal Board TB1	4-74
4-28	Ground Strap (Control Panel).....	4-76
4-29	Dummy Stowage Connector and Cover.....	4-77

LIST OF ILLUSTRATIONS - Continued

Figure	Title	Page
4-30	Reset Button	4-79
4-31	Power Distribution Block	4-82
4-32	Push (Door) Switches.....	4-84
4-33	V-Belt	4-86
4-34	Pulley.....	4-87
4-35	Ground Strap (Motor).....	4-88
4-36	AC Motor.....	4-90
4-37	Condenser Fan	4-93
4-38	Evaporator Fan.....	4-94
4-39	Sheave	4-95
4-40	Flange Bearing (Evaporator Fan)	4-97
4-41	Flange Bearing (Condenser Fan)	4-98
4-42	Solenoid Valve (Liquid Line).....	4-100
4-43	Solenoid Valve L2 (Defrost Line).....	4-102
4-44	Refrigeration Temperature Gage (Thermometer)	4-104
4-45	Grease Fitting Extension.....	4-106
4-46	Defrost Temperature Switch.....	4-108
4-47	Ground Strap (Compressor)	4-110
4-48	Heat Shield Gaskets.....	4-112
4-49	Refrigeration System Pump Down.....	4-114
4-50	Compress or Mount.....	4-115
5-1	Circuit Breaker Cover.....	5-4
5-2	Control Panel and Operating Instruction Plate	5-6
5-3	Fan Drive Shaft.....	5-7
5-4	Service Manifold Installation	5-9
5-5	Discharging Refrigerant.....	5-13
5-6	Nitrogen Tank Connection.....	5-15
5-7	Evacuation of Refrigerant System	5-20
5-8	Refrigerant Charging (Total System)	5-23
5-9	Refrigerant Charging (Partial System /Small Quantity Charge).....	5-25
5-10	Dehydrator	5-30
5-11	Strainer	5-32
5-12	Isolation Valves.....	5-34
5-13	Receiver	5-37
5-14	Condenser Coil	5-39
5-15	Pressure Regulator Valve.....	5-40
5-16	Metal Hose Assembly	5-42
5-17	Pressure Regulator Valve.....	5-43
5-18	Metal Hose Assembly.....	5-45
5-19	Accumulator.....	5-48

LIST OF ILLUSTRATIONS - Continued

Figure	Title	Page
5-20	Solenoid Valve.....	5-49
5-21	Solenoid Valve.....	5-51
5-22	Stop Valve.....	5-53
5-23	Stop Valve.....	5-55
5-24	Sight Indicator.....	5-57
5-25	Differential Oil Pressure Switch S5.....	5-59
5-26	Dual Pressure Control Switch.....	5-62
5-27	Dual Pressure Control Switch Settings.....	5-63
5-28	Compound Gage (Suction Pressure).....	5-64
5-29	Pressure Gage (Discharge Pressure).....	5-66
5-30	Heat Exchanger.....	5-68
5-31	Expansion Valve.....	5-70
5-32	Evaporator Coil.....	5-74
5-33	Compressor (Sheet 1 of 2).....	5-76
5-33	Compressor (Sheet 2 of 2).....	5-77
5-34	Tubing And Fittings.....	5-83
5-35	Left and Right Side Doors.....	5-87
5-36	Front Bottom Door.....	5-89
5-37	Front Top Door.....	5-91
5-38	Control Box Cover.....	5-93
C-1	Basic Issue Items.....	C-2
F-1	Tube, Copper Straight, Various.....	F-4
F-2	Tubing-Copper, Straight Flared, Various.....	F-4
F-3	Insulation Sleeving.....	F-5
F-4	Grommet, Part Number 500K1662-3-3 36.....	F-5
F-5	Gasket, Various.....	F-6
F-6	Chain, Sash, Part Number 12290-8-8000.....	F-6
F-7	Gasket, Top/Bottom, Part Number 148K0143.....	F-7
F-8	Gasket, Right/Left, Part Number 148K0144.....	F-7
F-9	Tube, Coil to Heat Exchanger, Part Number 148K0168.....	F-8
F-10	Tube Expansion, Valve to Heat Exchanger, Part Number 148K0169-1/T.....	F-8
F-11	Tube, Expansion, Valve Bypass, Part Number 148K0171.....	F-9
F-12	Tube, 0 375 Tee to Defrost Coil, Part Number 148K0173.....	F-9
F-13	Tube, Heat Exchanger to 0 375 Elbow, Part Number 148K0174.....	F-10
F-14	Tubing, Insulation, Part Number 149K000-1/99.....	F-10
F-15	Insulation Sound and Temperature, Part Number 149K0000-1/162.....	F-11
F-16	Gasket, Control Box, Top, Part Number 149K0032.....	F-11
F-17	Tube Assembly Inlet, Receiver, Part Number 149K0052-1/T.....	F-12
F-18	Tube Assembly, Outlet Receiver, Part Number 149K0053-1/T.....	F-12
F-19	Tube, Elbow to Elbow, Sight Glass Outlet, Part Number 149K0074.....	F-13

LIST OF ILLUSTRATIONS - Continued

Figure	Title	Page
F-20	Tube, Outlet, Accumulator, Part Number 149K0057	F-13
F-21	Tube, Outlet, Suction Pressure Regulator Valve, Part Number 149K0058	F-14
F-22	Tube, Outlet, Compressor, Part Number 149K0059-1/T	F-14
F-23	Tube, Outlet, Condenser Coil, Part Number 149K0075	F-15
F-24	Tube, Outlet, Discharge Pressure Regulator Valve, Part Number 149K0061	F-15
F-25	Tube Assembly, Outlet Strainer, Part Number 149K0063-1/T	F-16
F-26	Tube Assembly, Outlet, Solenoid Valve, Part Number 149K0064-1/T	F-16
	Tube, Inlet, Shut-Off Valve, Part Number 149K0065	F-17
F-28	Gasket, Cover, Control Box, Part Number 149K0072-1	F-17
F-29	Gasket, Circuit Breaker Panel, Part Number 151K0031	F-18
F-30	Contact Cradle, Sensing Bulb, Part Number 152K0194	F-18

LIST OF TABLES

Table	Title	Page
2-1	Operator Preventive Maintenance Checks and Services	2-8
4-1	Unit Preventive Maintenance Checks and Services	4-13
4-2	Monthly Mandatory Replacement Parts	4-23
4-3	Semi-Annually Mandatory Replacement Parts	4-23
4-4	Annual Mandatory Replacement Parts	4-23
5-1	Pressure Temperature Relationship of Saturated Refrigerant R-134a	5-27
5-2	Nominal Operating Pressure at Suction and Discharge Shut Off Valves	5-29

HOW TO USE THIS MANUAL

Be sure to read all Warnings before using this equipment.

This manual contains instructions for operation and maintenance of the Refrigeration Unit.

The front cover index of this manual lists the areas of the manual used most often and guides you to those sections. Follow the black mark on the cover index edge through the pages to the edge mark on the section you want. The subjects on the front cover index are also boxed in the table of contents. A detailed alphabetical index is located at the back of the manual.

Chapter 1 - Introduces you to the equipment and gives you information such as weight and dimensions used and general theory of operation including principles of operation.

Chapter 2 - Provides the operator with information necessary to identify and service the equipment. Operating instructions for usual and unusual conditions.

Chapter 3 - Provides operator lubrication tasks, and troubleshooting procedures for identifying common equipment malfunctions. Maintenance procedures for performing operator maintenance tasks.

Chapter 4 - Provides unit maintenance personnel with procedures for lubrication and service upon receipt of equipment and instructions for performing repairs on equipment as authorized by the maintenance allocation chart.

Chapter 5 - Provides direct support maintenance personnel with instructions for performing repairs on equipment as authorized by the maintenance allocation chart.

Chapter 6 - Provides general support maintenance personnel with instructions for performing repairs on equipment as authorized by the maintenance allocation chart.

Appendix A - Provides a list of frequently used forms and publications referenced or used in this manual.

Appendix B - The maintenance allocation chart identifies repairable components and the maintenance level authorized to perform the repairs.

Appendix C - List of components of end item and basic issue items to help you inventory the equipment.

Appendix D - List additional items that you are authorized for the support of the refrigeration unit.

Appendix E - List expendable and durable items needed to operate and maintain the refrigeration unit.

Appendix F - Provides you with instructions for making items authorized to be manufactured or fabricated at unit, direct support or general support maintenance.

Appendix G - List all mandatory replacement parts.

Alphabetical Index - Lists subject matter contained in manual in alphabetical order with the paragraph number.

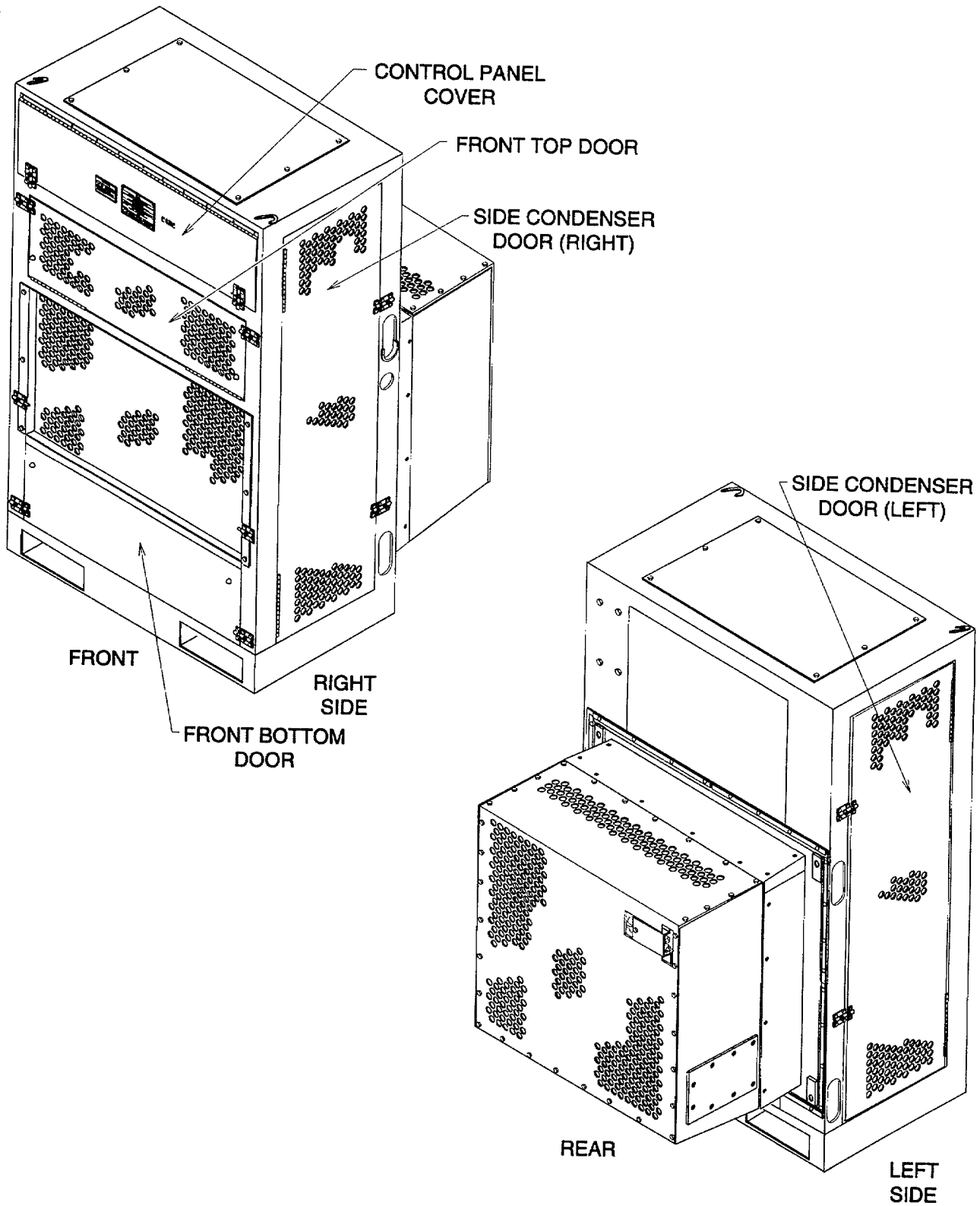

Figure 1-0. Refrigeration Unit

CHAPTER 1**INTRODUCTION****SECTION I GENERAL INFORMATION****1-1. SCOPE.**

- a. Type of Manual. Operator's, Unit, Direct Support and General Support Maintenance Manual.
- b. Model Number and Equipment Name. The Model F5000RE, Mechanical, Electric motor driven, 5,000 btu per hour Refrigeration Unit.
- c. Purpose of Equipment. The portable, field use refrigeration unit is intended to be used with a 150 cubic foot refrigerator covered by MIL-R-12571 and a 70 cubic foot refrigerator covered by MIL-R-43024.

1-2. MAINTENANCE FORMS, RECORDS AND REPORTS.

Department of the Army forms and procedures used for equipment maintenance will be those prescribed by DA Pam 738-750, The Army Maintenance Management System.

1-3. DESTRUCTION OF ARMY MATERIAL TO PREVENT ENEMY USE.

Refer to TM 750-244-3 for specific instructions on the destruction of army material to prevent enemy use.

1-4. PREPARATION FOR STORAGE OR SHIPMENT.

Refer to Chapter 4 for specific information under the same heading.

1-5. QUALITY ASSURANCE.

Requirement for specific quality assurance steps are not applicable to this equipment.

1-6. OFFICIAL NOMENCLATURE. NAMES AND DESIGNATIONS

The following listings include the nomenclature cross-reference list, list of abbreviations, and explanation of terms (glossary) used in this manual.

Nomenclature Cross-Reference List. A shortened nomenclature is used in this manual to make procedures easier for you to read A cross-reference between the shortened nomenclature and the official nomenclature is shown in the following table.

Manual Nomenclature	Official Nomenclature
Refrigeration Unit	Refrigeration Unit Mechanical, 5K btu, Electric, Model F5000RE
Refrigerator Enclosure	Prefabricated Panel Type Refrigerator

1-7. REPORTING EQUIPMENT IMPROVEMENT RECOMMENDATIONS (EIR)

If your refrigeration unit needs improvement, let us know Send us an EIR You, the user, are the only one who can tell us what you don't like about your equipment Let us know why you don't like the design or performance Put it on an SF 368 (Product Quality Deficiency Report) Mail it to:

Commander
 U S. Army Aviation and Troop Command
 ATTN- AMSAT-I-MDO
 4300 Goodfellow Blvd.
 St Louis, MO 63120-1798

1-8. WARRANTY INFORMATION

Refer to TB 9-4110-254-24 for specific warranty information.

1-9. CORROSION PREVENTION AND CONTROL

Corrosion Prevention and Control (CPC) of Army material is a continuing concern It is important that any corrosion problems with this item be reported so that the problem can be corrected and improvements can be made to prevent the problem in future items.

a. While corrosion is typically associated with rusting of metals, it can also include deterioration of other materials, such as rubber and plastic Unusual cracking, softening, swelling, or breaking of these materials may be corrosion problem.

b. If a corrosion problem is identified, it can be reported using Standard Form 368, Product Quality Deficiency Report Use of keywords such as "corrosion," "rust," "deterioration," or "cracking" will ensure that the information is identified as a CPC problem.

c. The form should be submitted to the address specified in DA Pam 738-750.

SECTION II EQUIPMENT DESCRIPTION

1-10. EQUIPMENT CHARACTERISTICS, CAPABILITIES AND FEATURES

a. Characteristics. The Keco Model F500ORE, is a self-contained, electric, three phase, motor driven, panel-mounted refrigeration unit used with a prefabricated panel type refrigerator. It requires a 208/230 volt ac, 50/60 Hertz power source.

b. Capabilities. The unit is capable of starting and operating in ambient temperature of 0° F to 125° F (-17° C to 52° C) and to automatically maintain a refrigerator temperature of 0° F to 35° F (-17° C to 20° C).

c. Features. The portion of the condensing unit exposed to weather is capable of operating in rainfall of three inches per hour without functional damage or impaired operation. This unit is designed to use R-134a refrigerant.

1-11. LOCATION AND DESCRIPTION OF MAJOR COMPONENTS

- 1 CONTROL BOX ASSEMBLY. Houses the automatic and manual electrical control components.
- 2 EVAPORATOR COIL . Absorbs heat from the air being circulated through the refrigerator enclosure causing the low pressure liquid refrigerant in the coil to evaporate.
- 3 COMPRESSOR. Moves the refrigerant through the refrigeration system by raising the pressure of the incoming gas from the evaporator coil and discharging it as a high pressure gas.
- 4 CONDENSER COIL. Releases heat from the high pressure gas coming from the compressor causing the gas to condense into a high pressure liquid.
- 5 AC MOTOR. Drives the air handling components.
- 6 EVAPORATOR FAN. Circulates air through the refrigerator and across the evaporator coil.
- 7 CONDENSER FAN. Circulates ambient, outside air, across the condenser coil.
- 8 DUAL PRESSURE CONTROL SWITCH. Provides over/under pressure protection for the refrigeration system. The switch has a manual reset for overpressure conditions.
- 9 DIFFERENTIAL OIL PRESSURE SWITCH. Provides protection against loss of lubricating oil in the compressor. The switch has a manual reset for low oil conditions.

1-11. LOCATION AND DESCRIPTION OF MAJOR COMPONENTS. - Continued

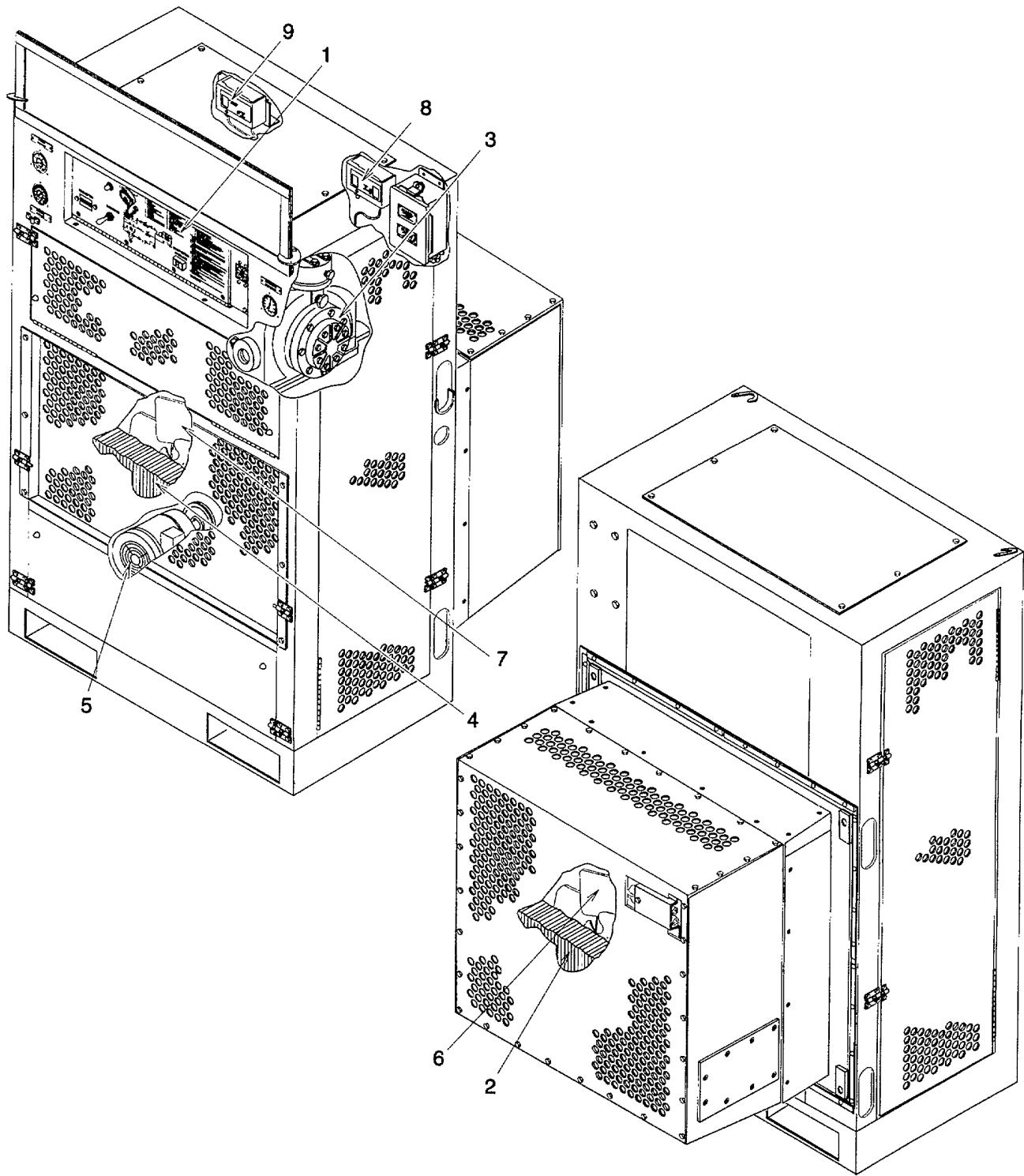

Figure 1-1. Major Components

1-12. EQUIPMENT DATA.

WEIGHTS AND DIMENSIONS

Weight 790 lb (358 Kg)

Width35.0 m (88. 9 cm)

Height56.5 m. (143.5 cm)

Depth 35.1 in. (89. 2 cm)

PERFORMANCE

Cooling Capacity

0° F (-18° C).....5,000 btuh

35° F (2° C).....7,500 btuh

ELECTRICAL CHARACTERISTICS

Voltage208/230 Vac

Frequency 50/60 Hz

Current12 amp

FLUID CAPACITIES

Refrigerant R134a 10. 0 lb (4.5 Kg)

SECTION III PRINCIPLES OF OPERATION**1-13. ELECTRICAL SYSTEM**

The refrigeration unit requires electrical power to operate. A power supply cable (not supplied) must be connected between the enclosure assembly and a source of electrical power. The circuit breaker receives power from the electrical cable assembly and distributes it to the various components and circuits in the control box assembly. The control box assembly houses various automatic and manual components which control the compressor, and ac motor. The compressor causes refrigerant flow through the refrigeration system, and the ac motor drives the air handling system.

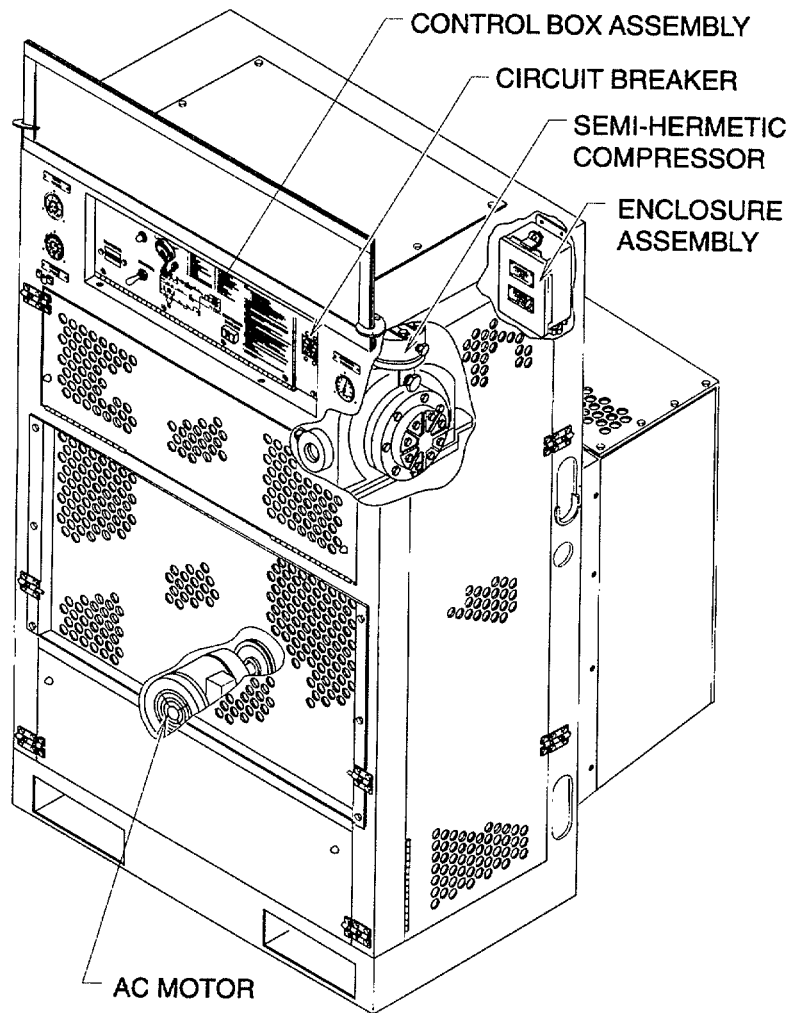
**Figure 1-2. Electrical System**

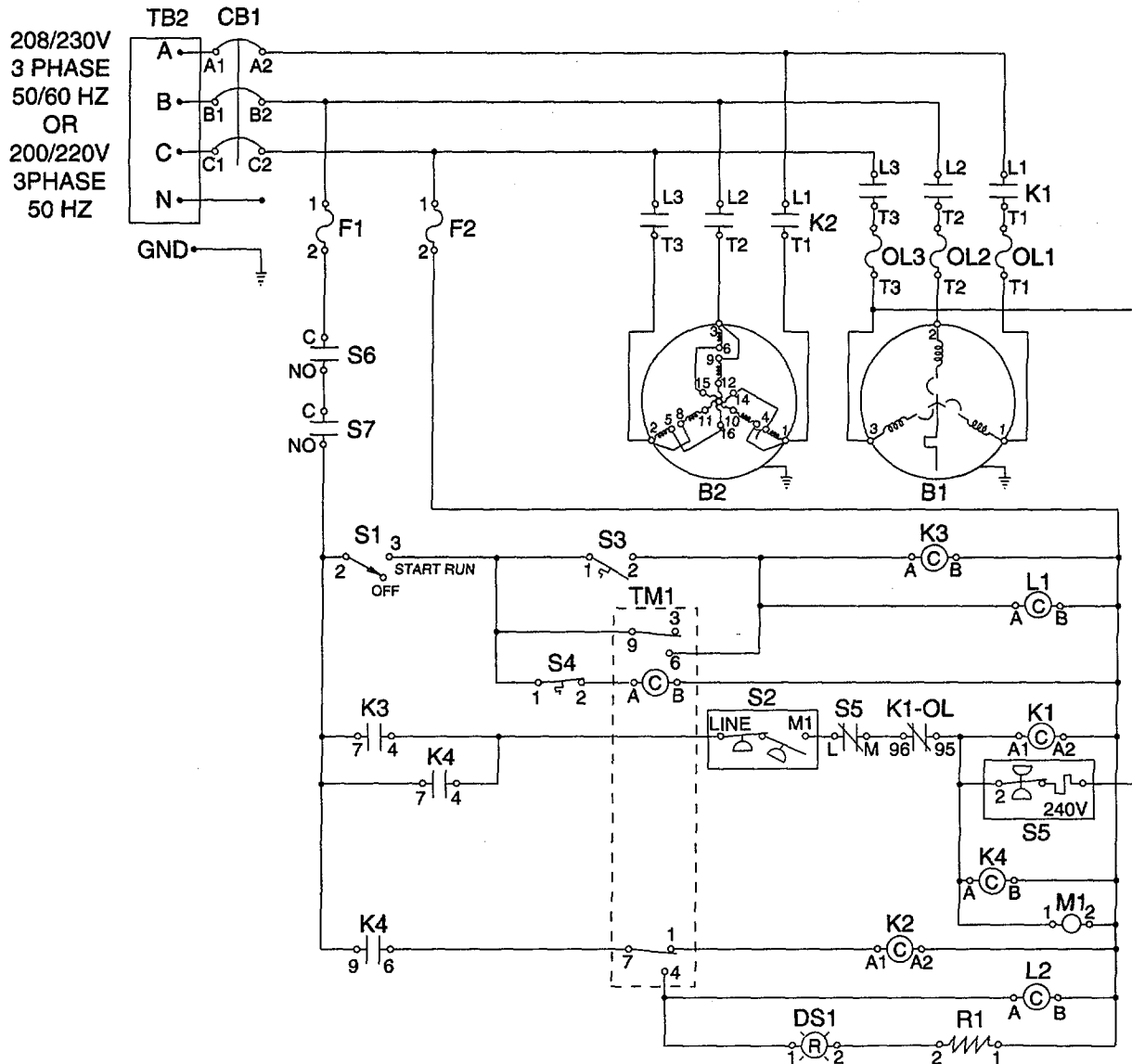

LEGEND			
ITEM	DESCRIPTION	ITEM	DESCRIPTION
B1	COMPRESSOR, SEMI-HERMETIC	M1	HOURMETER
B2	MOTOR, A.C. (FAN)	OL1-3	HEATER, OVERLOAD
CB1	CIRCUIT BREAKER (MAIN)	R1	RESISTOR, 10 WATT
DS1	LIGHT, INDICATOR (DEFROST IN PROGRESS)	S1	SWITCH, TOGGLE (START/RUN-OFF)
F1,2	FUSE (6 AMP)	S2	SWITCH, REFRIGERANT PRESSURE
K1	STARTER, MOTOR	S3	THERMOSTAT, REMOTE BULB
K2	RELAY, POWER (FAN)	S4	SWITCH, TEMP (DEFROST TERMINATION)
K3,4	RELAY, CONTROL	S5	SWITCH, DIFFERENTIAL OIL PRESSURE
L1	SOLENOID VALVE, NC (LIQUID LINE)	S6,7	SWITCH, PUSHBUTTON (DOOR)
L2	SOLENOID VALVE, NC (DEFROST)	TB2	TERMINAL BLOCK
		TM1	TIMER, DEFROST

Figure 1-3. Electrical Schematic

1-13. ELECTRICAL SYSTEM. - Continued

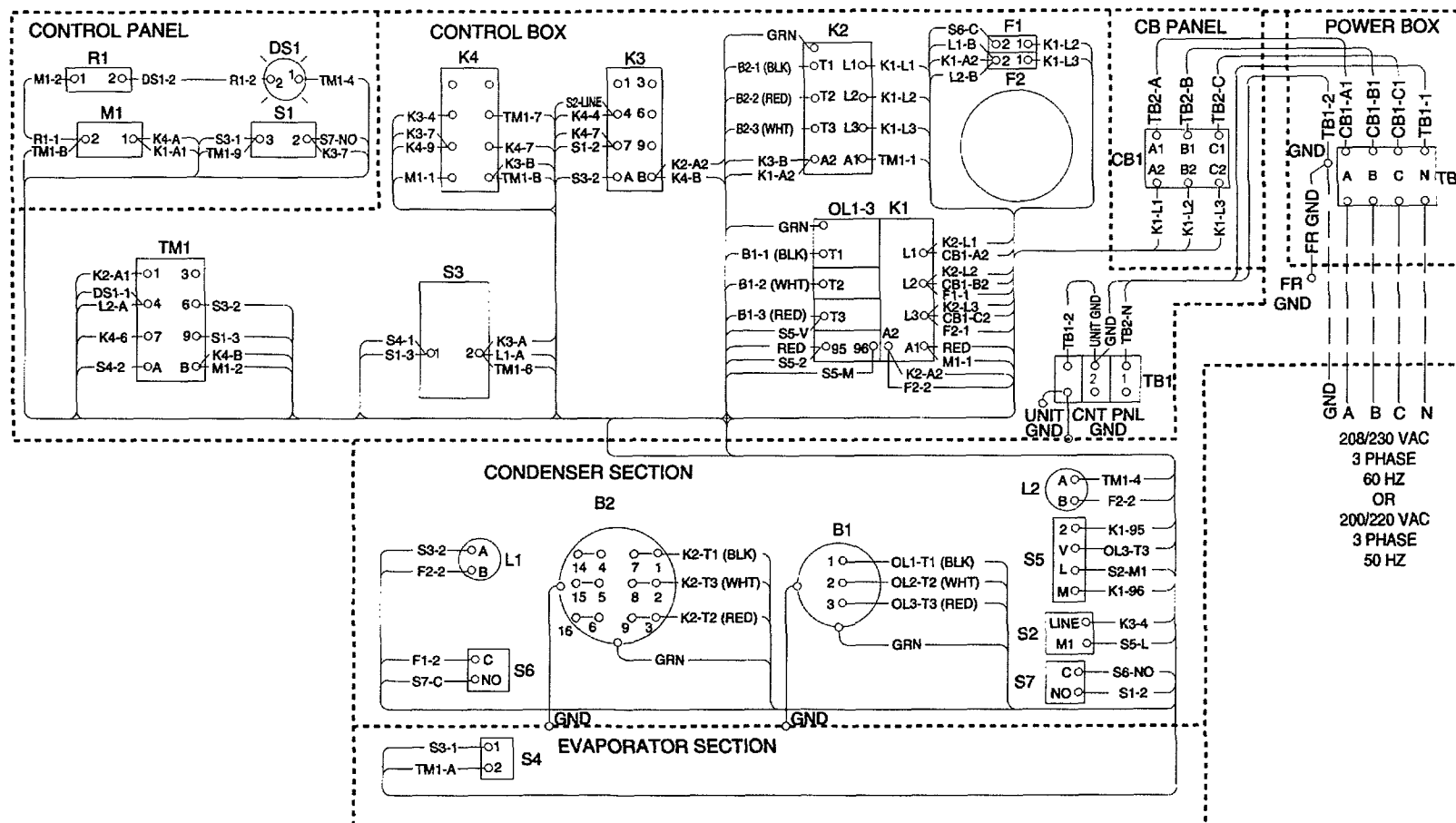

Figure 1-4. Electrical Wiring Diagram (Sheet 1 of 2)

LEGEND			
ITEM	DESCRIPTION	ITEM	DESCRIPTION
B1	CONDENSER	OL1-3	HEATER, OVERLOAD
B2	MOTOR, A.C. (FAN)	R1	RESISTOR, 10 WATT
CB1	CIRCUIT BREAKER (MAIN)	S1	SWITCH, TOGGLE (START/RUN-OFF)
DS1	LIGHT, INDICATOR (DEFROST IN PROGRESS)	S2	SWITCH, REFRIGERANT PRESSURE
F1,2	FUSE (6 AMP)	S3	THERMOSTAT, REMOTE BULB
K1	STARTER, MOTOR	S4	SWITCH, TEMP (DEFROST TERMINATION)
K2	RELAY, POWER (FAN)	S5	SWITCH, DIFFERENTIAL OIL PRESSURE
K3,4	RELAY, CONTROL	S6,7	SWITCH, PUSHBUTTON (DOOR)
L1	SOLENOID VALVE, NC (LIQUID LINE)	TB1	TERMINAL BOARD
L2	SOLENOID VALVE, NC (DEFROST)	TB2	TERMINAL BLOCK
M1	HOURMETER	TM1	TIMER, DEFROST

Figure 1-4. Electrical Wiring Diagram (Sheet 2 of 2)

1-14. REFRIGERATION SYSTEM.

a. Cooling Cycle. Heat is absorbed from the refrigerator enclosure and released to the outside ambient air using refrigerant flowing through the refrigeration system. The compressor moves the refrigerant through the refrigeration system by raising the pressure of the incoming gas from the evaporator coil (evaporator) and discharging it as a high pressure gas. The high pressure gas passes through the condenser coil (condenser) where heat is released to the outside ambient air causing the high pressure gas to condense to a high pressure liquid. The high pressure liquid, which may contain some gas, is collected in the receiver. The receiver contains a dip tube that allows only liquid to flow from it. The high pressure liquid passes through the heat exchanger where it is cooled by low pressure gas returning to the compressor. The high pressure liquid passes through the expansion valve (thermostatic expansion valve) which causes a pressure drop and automatically meters the amount of liquid passing through it. The rapid drop in pressure causes the liquid to cool. The cool, low pressure liquid passes through the evaporator coil where heat is absorbed from the refrigerator enclosure air causing the low pressure liquid to evaporate to a low pressure gas. The low pressure gas passes through the heat exchanger where it absorbs heat from the high pressure liquid going into the expansion valve. The low pressure gas, which may contain some liquid, is collected in the accumulator (suction accumulator). The accumulator separates the low pressure gas from any liquid and allows only gas to flow from it. The low pressure gas returns to the compressor to begin the cycle again.

b. Defrost Cycle. By lowering the temperature in the refrigerator enclosure to a temperature below freezing, any moisture that accumulates on the evaporator coil will freeze and prevent proper air circulation through the coil. The defrost cycle is automatically controlled by a temperature sensor and electronic timer in the electrical system. The evaporator coil is defrosted when high pressure gas is sent from the compressor directly into the coil. To prevent water from freezing in the evaporator coil drip pan, the warm high pressure gas tubing is routed through the drain hole in the drip pan. The high pressure gas tubing then serpentine across the bottom of the drip pan before entering the coil. The high pressure gas is then returned to the compressor to begin the cycle again. The defrost cycle will continue until either the temperature sensor or electronic timer terminates it.

1-14. REFRIGERATION SYSTEM. - Continued

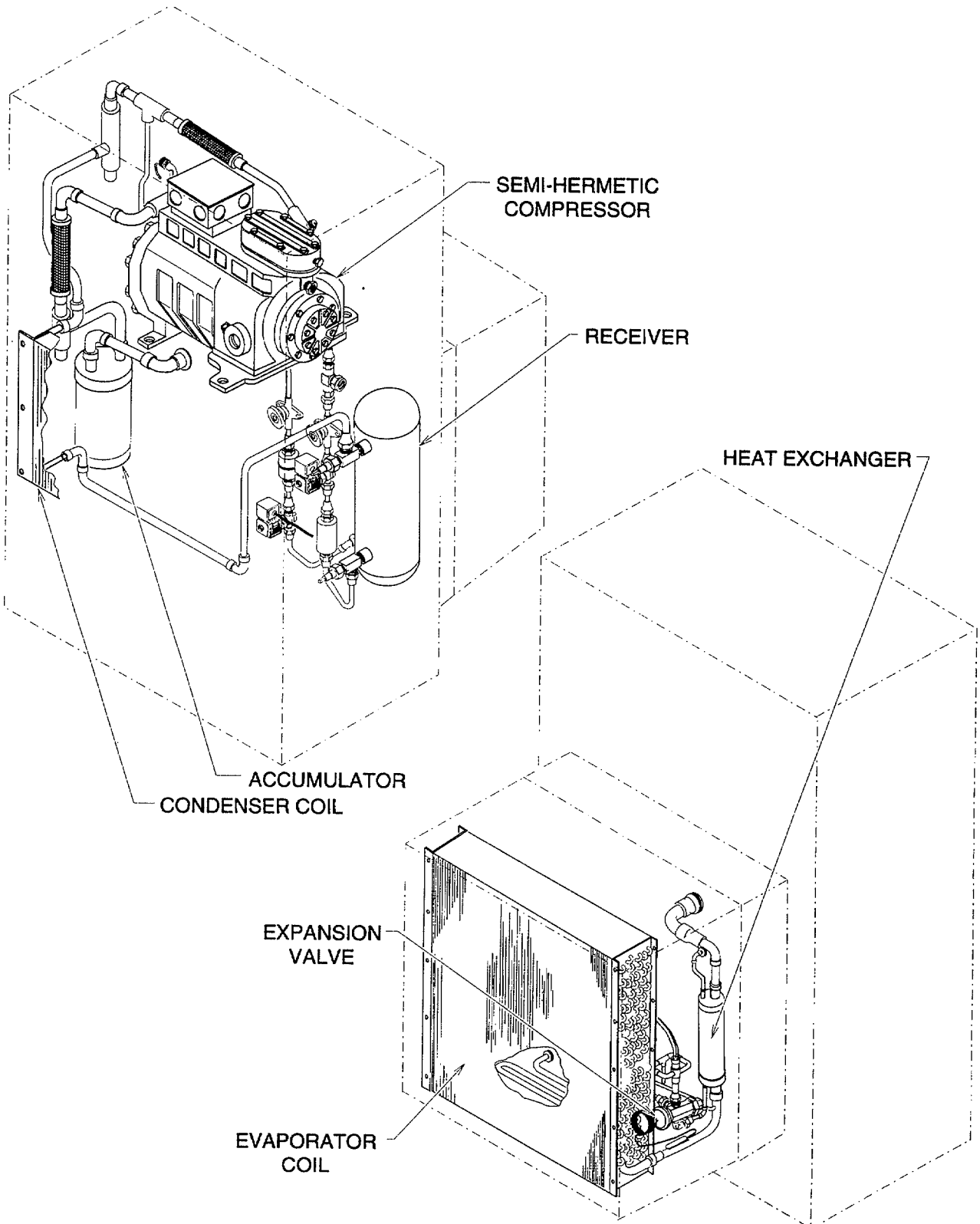
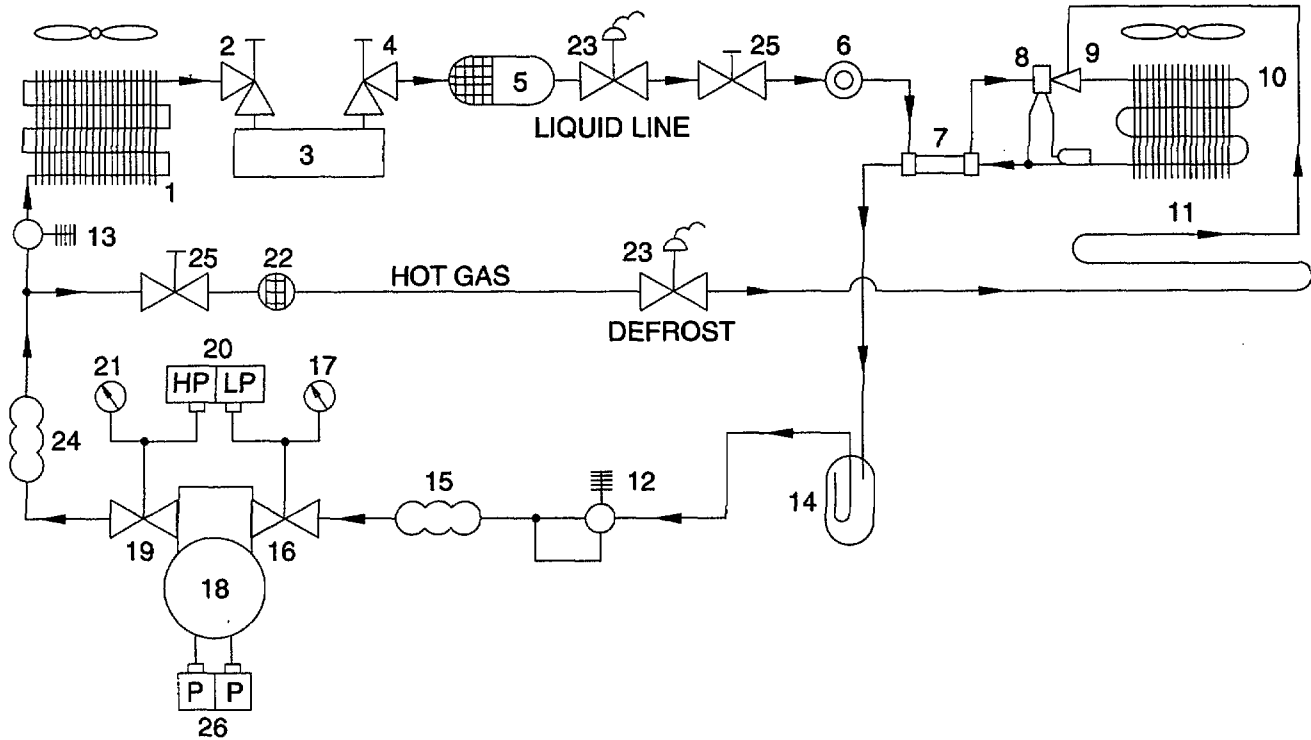

Figure 1-5. Refrigeration System



LEGEND			
ITEM	DESCRIPTION	ITEM	DESCRIPTION
1	CONDENSER	15	VIBRATION ABSORBER
2	SHUT-OFF VALVE	16	SUCTION SERVICE VALVE
3	RECEIVER	17	COMPOUND GAUGE
4	SHUT-OFF VALVE	18	SEMI-HERMETIC COMPRESSOR
5	FILTER DRIER	19	DISCHARGE SERVICE VALVE
6	MOISTURE LIQUID INDICATOR	20	DUAL PRESSURE CUTOUT SWITCH
7	HEAT EXCHANGER	21	HEAD PRESSURE GAUGE
8	THERMOSTATIC EXPANSION VALVE	22	STRAINER
9	DISTRIBUTOR	23	SOLENOID VALVE
10	EVAPORATOR	24	VIBRATION ABSORBER
11	DEFROST COIL	25	SHUT-OFF VALVE
12	CRANKCASE PRESSURE REGULATOR	26	DIFFERENTIAL OIL PRESSURE SWITCH
13	DISCHARGE PRESSURE REGULATOR		
14	SUCTION ACCUMULATOR		

Figure 1-6. Refrigeration Schematic

1-15. AIR HANDLING SYSTEM

a. Refrigerator Enclosure. To absorb heat and cool the refrigerator enclosure, air must be circulated through the evaporator section of the refrigeration unit. Refrigerator enclosure air is drawn in through the coil guard and evaporator coil by the evaporator fan. The air is discharged through the evaporator air outlet guard back into the refrigerator enclosure.

b. Outside Ambient. To release heat absorbed from the refrigerator enclosure to the outside ambient, air must be circulated through the condenser section of the refrigeration unit. Outside ambient air is drawn in through the condenser guard and condenser coil by the condenser fan. The air is discharged through the side condenser doors and front bottom panels back to the outside ambient.

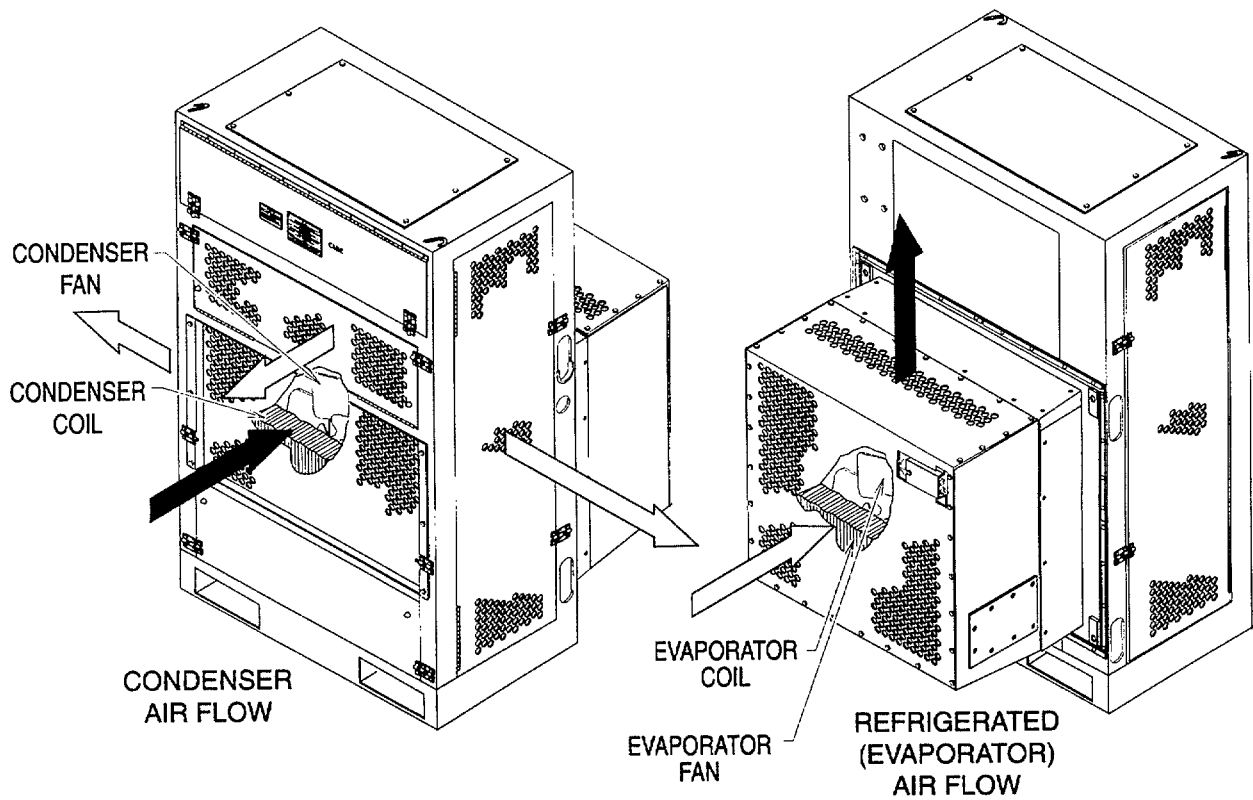

Figure 1-7. Air Flow

CHAPTER 2
OPERATING INSTRUCTIONS

		Page
Section I	DESCRIPTION AND USE OF OPERATOR'S CONTROLS AND INDICATORS	
	INDICATORS	2-1
2-1	Operating Controls and Indicators	2-1
2-2	Fault Controls and Indicators	2-4
Section II	PREVENTIVE MAINTENANCE CHECKS AND SERVICES (PMCS)	2-6
2-3	General.....	2-6
Section III	OPERATION UNDER USUAL CONDITIONS.	2-17
2-4	Assembly and Preparation for Use	2-17
2-5	Startup Procedures	2-17
2-6	Operator Checks.....	2-19
2-7	Shutdown Procedures	2-19
2-8	Decals and Instruction Plates	2-19
Section IV	OPERATION UNDER UNUSUAL CONDITIONS	2-22
2-9	Operation Under Inclement Weather.....	2-22
2-10	NBC Decontamination Procedures.....	2-22

SECTION I DESCRIPTION AND USE OF OPERATOR'S CONTROLS AND INDICATORS

2-1. OPERATING CONTROLS AND INDICATORS.

The controls and indicators needed to operate and monitor the refrigeration unit are located on the control box assembly and condenser frame.

- 1 Circuit Breaker (MAIN CIRCUIT BREAKER). Provides electrical circuit protection for the refrigeration unit. The circuit breaker handle should be in the ON position
- 2 Remote Bulb Thermostat (TEMPERATURE CONTROL). Monitors and automatically controls the temperature inside the refrigerator enclosure The remote bulb thermostat should be set to the desired refrigerator enclosure temperature
- 3 Toggle Switch (START/RUN, OFF). Activates the refrigeration unit The toggle switch should be in the START/RUN position.
- 4 Thermometer (REFRIGERATION TEMPERATURE). Indicates the refrigerator enclosure temperature. The thermometer should indicate within 15° F (7° C) of the temperature set on the remote bulb thermostat.

2-1. OPERATING CONTROLS AND INDICATORS. - Continued

- 5 Pressure Gage (DISCHARGE PRESSURE). Indicates the pressure of the refrigerant gas leaving the compressor. The pressure gage should generally indicate between 160 and 270 psi (1104 and 1863 kPa), at start up and/or operation in high temperatures, this range can go higher. The inner scale indicates the temperature of the refrigerant at any given pressure.
- 6 Compound Gage (SUCTION PRESSURE). Indicates the pressure of the refrigerant gas entering the compressor. The compound gage should generally indicate between 0 and 15 psi (0 and 104 kPa), during pump down and/or operation in low temperatures, this range can go lower. The inner scale indicates the temperature of the refrigerant at any given pressure.
- 7 Sight Indicator (REFRIGERANT SIGHT GLASS). Provides a port through which the refrigerant may be observed as it passes through the liquid line of the refrigeration system. The center indicator changes color as it reacts to moisture in the refrigerant. The sight indicator port should be clear, indicating liquid refrigerant passing through it. An occasional flash of bubbles is normal as the refrigerant system automatically adjusts to changing conditions. The center indicator should be green or chartreuse in color.
- 8 Sight Glass (COMPRESSOR OIL SIGHT GLASS). Provides a port through which the oil level in the compressor may be observed. The sight glass port should show an oil level between 1/4 and 1/2 up the port. Bubbles in or on the oil surface is normal.
- 9 Hourmeter (HOURMETER). Indicates the total number of hours the compressor has operated.
- 10 Indicator (DEFROST IN PROGRESS). Indicates, by illuminating, when the refrigeration unit is operating in a defrost cycle.

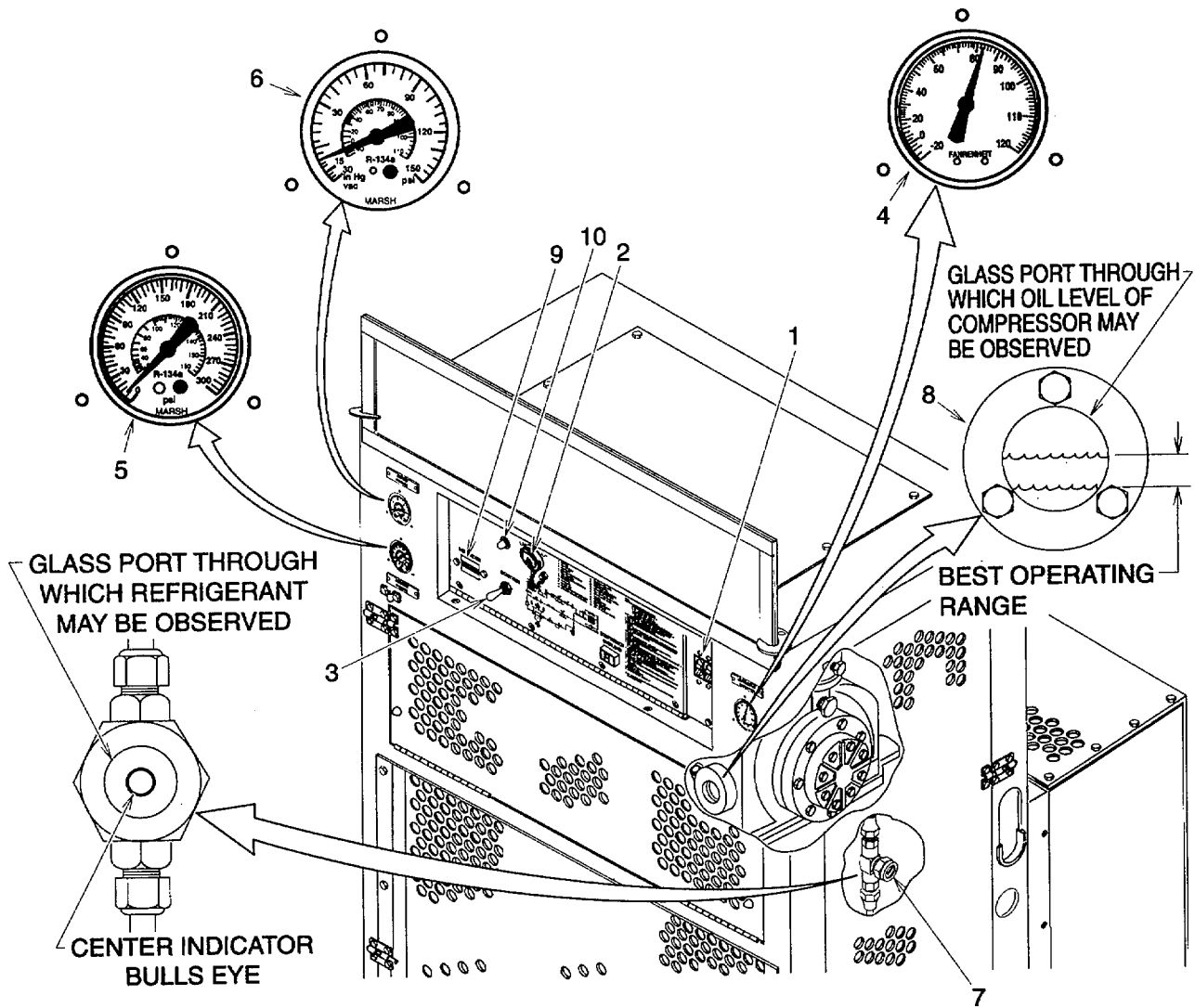

Figure 2-1. Operating Controls and Indicators

2-2. FAULT CONTROLS AND INDICATORS

The controls and indicators needed to monitor and reset a fault condition on the refrigeration unit are located on the control box assembly and inside the condenser frame.

- 1 Thermometer (REFRIGERATION TEMPERATURE). The thermometer will indicate more than 15° F (70 C) above or below the remote bulb thermostat setting if a fault occurs in the temperature control system.
- 2 Pressure Gage (DISCHARGE PRESSURE). The pressure gage will indicate more than 270 psi (1863 kPa) or less than 160 psi (1104 kPa) if a fault occurs in the refrigeration system. At start up, shut down, or operation in high temperatures, this range can go higher.
- 3 Compound Gage (SUCTION PRESSURE). The pressure gage will indicate more than 15 psi (104 kPa) or less than 0 psi (0 kPa) if a fault occurs in the refrigeration system. At start up, shut down, or operation in low temperatures, this range can go lower.
- 4 Circuit Breaker (MAIN CIRCUIT BREAKER). The circuit breaker will be in a mid-way position if a fault has caused excessive load on the electrical system. To reset the circuit breaker, move the handle to the OFF position and then back to the ON position.
- 5 Reset Button (COMPRESSOR OVERLOAD). The reset button resets the motor starter if a fault has caused the compressor to overload. Push the reset button to reset the motor starter.
- 6 Dual Pressure Control Switch. The dual pressure control switch will open the electrical control circuit if a fault in the refrigeration system causes the pressure of the refrigerant gas leaving the compressor to exceed 300 psi (2070 kPa). Push the reset button to reset the dual pressure control switch.
- 7 Differential Oil Pressure Switch. The differential oil pressure switch will open the electrical control circuit if a fault in the refrigeration system causes the compressor oil pressure to drop. Push the reset button to reset the differential oil pressure switch.
- 8 Sight Indicator (REFRIGERANT SIGHT GLASS). The sight indicator port will show continuous bubbles or foam in the refrigerant if there is a fault in the refrigeration system. The center indicator color will be yellow if moisture in the refrigerant exceeds safe operating limits.
- 9 Sight Glass (COMPRESSOR OIL SIGHT GLASS). The sight glass port will show the compressor oil level less than 1/4 up the port or will show the oil foaming if there is a fault in the refrigeration system.

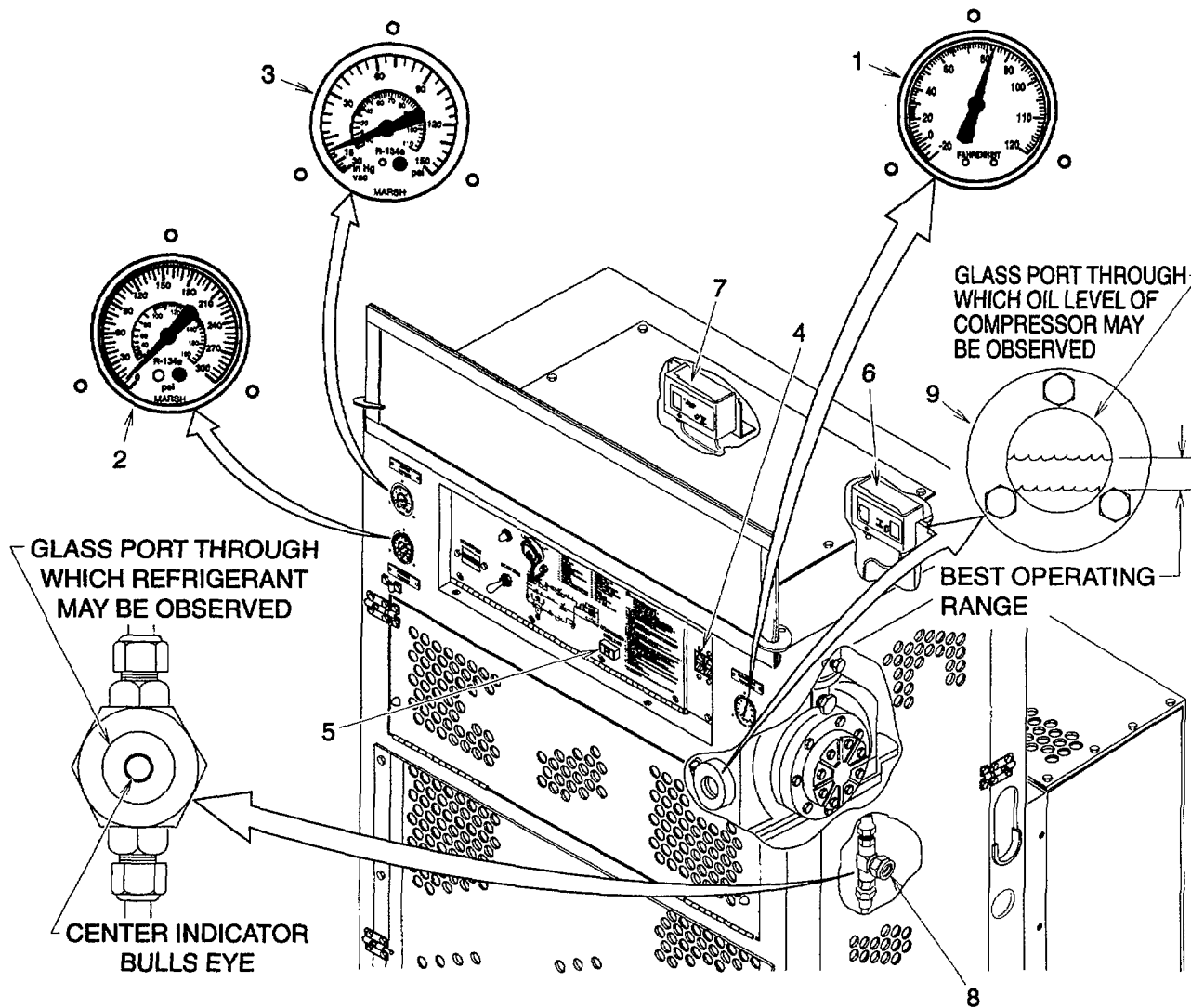

Figure 2-2. Fault Controls and Indicators

SECTION II OPERATOR PREVENTIVE MAINTENANCE CHECKS AND SERVICES (PMCS)2-3. GENERAL.

Preventive Maintenance Checks and Services (PMCS) are essential to the efficient operation of the refrigeration unit and to prevent possible damage that might occur through neglect or failure to observe warning symptoms in a timely manner. Checks and services performed by operators are limited to those functions which can be done from the outside of the cabinet. The Preventive Maintenance Checks and Services Table 2-1 lists the inspections and care of the refrigeration unit required to keep it in good operating condition.

a. Warning and Cautions. Always observe the WARNINGS and CAUTIONS appearing in your PMCS Table. WARNINGS and CAUTIONS appear before applicable procedures. You must observe these WARNINGS and CAUTIONS to prevent serious injury to yourself and others or prevent your equipment from being damaged.

b. Explanation of Table Entries.

(1) Item Number Column. Numbers in this column are for reference. When completing DA Form 2404 (Equipment Inspection and Maintenance Worksheet), include the item number for the check/service indicating a fault. Item numbers also appear in the order that you must do checks and services for the intervals listed.

(2) Interval Column. This column tells you when you must do the procedure in the procedure column. BEFORE procedures must be done before you operate or use the equipment for its intended mission. DURING procedures must be done during the time you are operating or using the equipment for its intended mission. AFTER procedures must be done immediately after you have operated or used the equipment. When a check and service procedure is required for both WEEKLY and BEFORE intervals, it is not necessary to do the procedure twice if the equipment is operating during the WEEKLY period.

(3) Location, Check/Service Column. This column provides the location and the item to be checked or serviced. The item location is underlined.

(4) Procedure Column. This column gives the procedure you must do to check or service the item listed in the Check/Service column to know if the equipment is ready or available for its intended mission or for operation. You must do the procedure at the time stated in the interval column.

(5) Not Fully Mission Capable IF: Column. Information in this column tells you what faults will keep your equipment from being capable of performing its primary mission. If you made a check and service procedure that shows faults listed in this column, do not operate the equipment. Follow standard operating procedures for maintaining the equipment or reporting equipment failure.

c. Other Table Entries. Be sure to observe all special information and notes that appear in your table.

d. Refrigerant Leaks. Oil is carried with the refrigerant as it flows through the refrigeration system. If a leak develops in the system, the oil will seep out and soak the copper tubing around the leak or drip and soak or puddle on the frame or other component below the leak. If any oil or seepage is found, a refrigerant leak would be suspected.

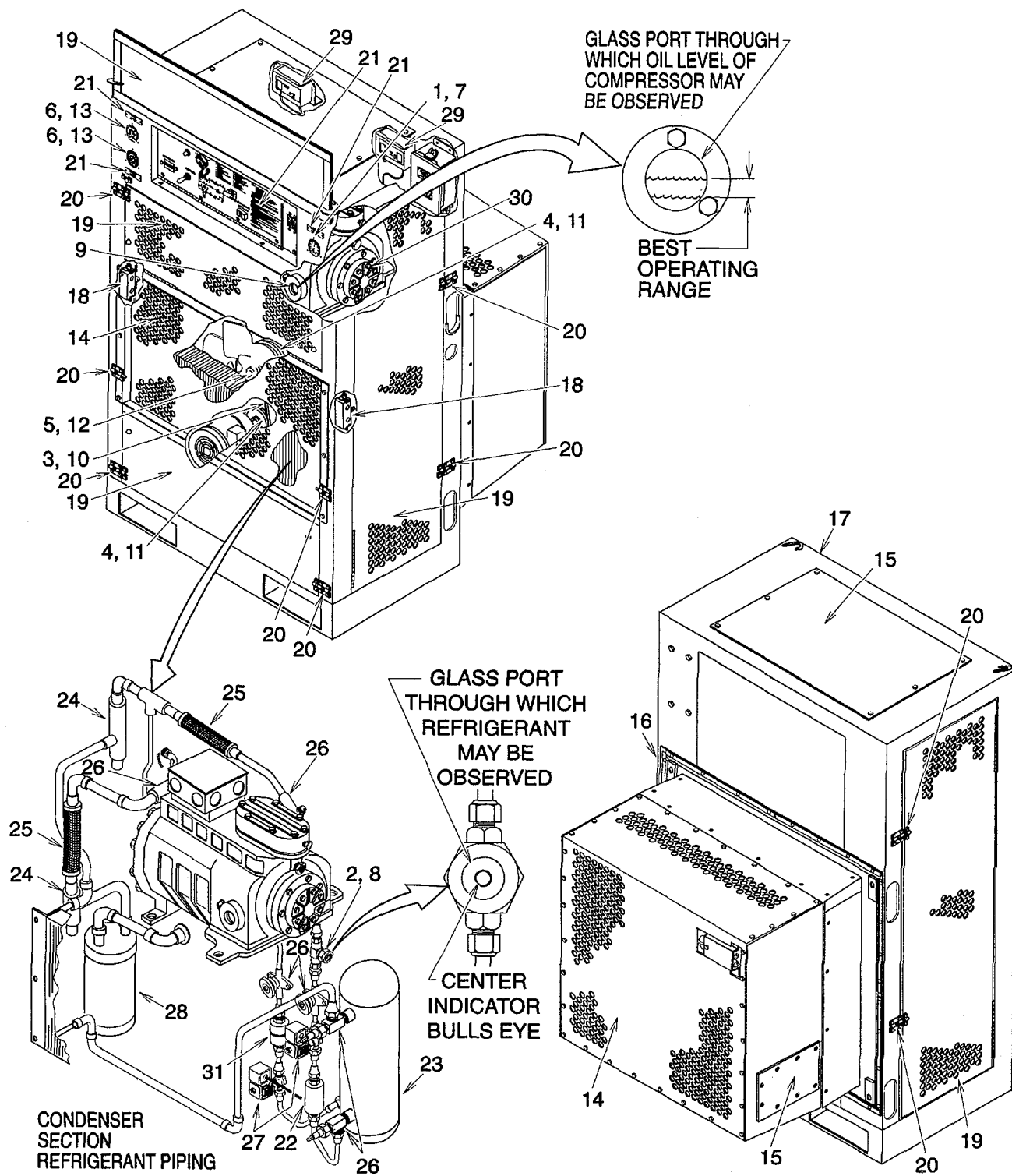

Figure 2-3. Operator's PMCS Routing Diagram

Table 2-1. Operator Preventive Maintenance Checks and Services

NOTE

If the equipment must be kept in continuous operation, do only the procedures that can be done without disturbing operation. Make complete checks and services when the equipment is shutdown.

Item No.	Interval	Location		Procedure	Not Fully Mission Capable If:
		Item to Check/ Service			
1	Before	Refrigeration Unit Exterior	Thermometer	<p>a. Thermometer should indicate refrigerator enclosure temperature. If it does not, notify unit maintenance to replace it.</p> <p>b. Inspect the thermometer for cracked or missing lens and loose or missing mounting hardware. If damaged or loose, notify unit maintenance to tighten or replace it as necessary.</p>	Thermometer does not indicate refrigerator enclosure temperature
		Refrigeration Unit Interior		<div style="text-align: center; border: 1px solid black; padding: 2px; width: fit-content; margin: 0 auto;"> WARNING </div> <p>High voltage and exposed rotating parts are contained in the refrigeration unit. Personal injury can result if power is connected with doors open.</p>	
2	Before	Sight Indicator		<p>a. Inspect sight indicator port for cracks and note center indicator color. If cracked or yellow, notify direct support maintenance to replace it or evacuate the refrigeration system as necessary</p> <p>b. Inspect the sight indicator for evidence of refrigerant leak. If evidence of leaking found, notify direct support maintenance to replace it.</p>	<p>Sight indicator port is cracked or center indicator color is yellow.</p> <p>Evidence of leak is found.</p>
		V-Belt		<p>Inspect the V-belt for frayed edges, cracks, glazing, or hard brittle condition. Inspect for excessive looseness or slippage. If damaged or loose, notify unit maintenance to tighten or replace it as necessary.</p>	<p>V-Belt is frayed, cracked, glazed, or hard and brittle. V-Belt is excessively loose or slipping.</p>

Table 2-1. Operator Preventive Maintenance Checks and Services - Continued

Item No	Interval	Location	Procedure	Not Fully Mission Capable If:
		Item to Check/ Service		
4	Before	Pulleys	Inspect pulleys for cracks, chips, or warpage. Inspect for secure mounting to shaft. If damaged or loose, notify unit maintenance to tighten or replace it as necessary.	Pulleys are cracked, chipped, warped, or loose on shaft.
5	Before	Fan Drive Shaft	Inspect fan drive shaft for cracks, chips, or warpage. If damaged, notify unit maintenance to replace it as necessary.	Fan drive shaft is cracked, chipped, or warped.
		<u>Refrigeration Unit Exterior</u>	<p style="text-align: center;">NOTE</p> <ul style="list-style-type: none"> • The gages must not be inspected when the DEFROST IN PROGRESS indicator is on. • Pressures given are the acceptable operating range. 	
6	During	Pressure Gages	Inspect the (high) pressure gage for reading between 160 and 270 psi (1104 and 1863 kPa) and the (low) compound gage for reading between 0 and 15 psi (0 and 104 kPa). If either gage is out of acceptable operating range on a continuous basis, note the readings and shut down the refrigeration unit. Notify unit maintenance of the pressure readings.	Gage reading above or below acceptable operating range.
			<p style="text-align: center;">NOTE</p> <p style="text-align: center;">The thermometer must not be inspected when the DEFROST IN PROGRESS indicator is on.</p>	
7	During	Thermometer	Thermometer should indicate within 15° F (7° C) of TEMPERATURE CONTROL setting. If out of this range, shut down refrigeration unit and notify unit maintenance.	Thermometer indicates more than 15° F (7° C) above or below TEMPERATURE CONTROL setting.

Table 2-1. Operator Preventive Maintenance Checks and Services - Continued

Item No	Interval	Location	Procedure	Not Fully Mission Capable If:
		Item to Check/ Service		
8	During	Sight Indicator (Refrigerant)	<p style="text-align: center;">NOTE</p> <ul style="list-style-type: none"> • The sight indicator must not be inspected when the DEFROST IN PROGRESS indicator is on. • The sight indicator can be viewed looking through the left side condenser door. <p>Inspect sight indicator port for constant bubbles or foaming and note center indicator color. If constant bubbles or yellow indicator are seen, shut down refrigeration unit and notify direct support maintenance to leak check and evacuate refrigeration system as necessary.</p>	Sight indicator port shows constant bubbles or foam. Center indicator color is yellow.
9	During	Compressor (Oil Level Sight Glass)	<p style="text-align: center;">NOTE</p> <ul style="list-style-type: none"> • The sight glass must not be inspected when the DEFROST IN PROGRESS indicator is on. • The sight glass can be viewed looking through the front top panel. • Safe operating level is between 1/4 and 1/2 way up the sight glass. <p>Inspect the sight glass port for low or high oil level and foaming. If oil level is out of safe operating range or foaming, shut down refrigeration unit and notify direct support maintenance to leak check and add oil to or remove oil from compressor as necessary.</p>	Sight glass port oil level above or below safe operating range or foaming.

Table 2-1. Operator Preventive Maintenance Checks and Services - Continued

Item No	Interval	Location	Procedure	Not Fully Mission Capable If:
		Item to Check/ Service		
		<u>Refrigeration Unit Interior</u>	<div style="border: 1px solid black; padding: 2px; text-align: center; margin: 0 auto; width: fit-content;"> WARNING </div> <p>High voltage and exposed rotating parts are contained in the refrigeration unit. Personal injury can result if power is connected with doors open.</p>	
10	After	V Belt	Inspect the V belt for frayed edges, cracks, glazing, or hard brittle condition. Inspect for excessive looseness or slippage. If damaged or loose, notify unit maintenance to tighten or replace it as necessary.	V belt is frayed, cracked, glazed, or hard and brittle. V belt is excessively loose or slipping.
11	After	Pulleys	Inspect pulleys for cracks, chips, or warpage. Inspect for secure mounting to shaft. If damaged or loose, notify unit maintenance to tighten or replace it as necessary.	Pulleys are cracked, chipped, warped, or loose on shaft.
12	After	Fan Drive Shaft	Inspect fan drive shaft for cracks, chips, or warpage. If damaged, notify unit maintenance to replace it as necessary.	Fan drive shaft is cracked, chipped, or warped.
13	Weekly	<u>Refrigeration Unit Exterior</u> Pressure Gages	a. Inspect the pressure gages for cracked or missing lens and loose or missing mounting hardware. If damaged or loose, notify direct support maintenance to tighten or replace it as necessary. b. Inspect the gages for evidence of refrigerant leak. If damaged or evidence of leaking found, notify direct support maintenance to replace it.	Evidence of leak is found.

Table 2-1. Operator Preventive Maintenance Checks and Services - Continued

Item No	Interval	Location	Procedure	Not Fully Mission Capable If:
		Item to Check/ Service		
14	Weekly	Coil Guard/Cover Panel	<ul style="list-style-type: none"> a. Inspect the coil guard and cover panel for any debris or foreign material obstructing the openings. Remove any debris or foreign material from the openings. If debris cannot be removed, notify unit maintenance to remove it. b. Inspect the coil guard and cover panel for any cracks, tears, and loose or missing hardware. If cracked, notify direct support maintenance for repair. If hardware is loose or missing, notify unit maintenance to tighten or replace as necessary. c. Inspect for chipped or missing paint and evidence of corrosion. If paint is damaged or shows evidence of corrosion, notify direct support maintenance to paint it. 	Debris or foreign material obstructs the openings.
15	Weekly	Access Panels	<ul style="list-style-type: none"> a. Inspect the access panels for any debris or foreign material obstructing the openings. Remove any debris or foreign material from the access panel openings. If debris cannot be removed, notify unit maintenance to remove it. b. Inspect the access panels for any cracks, tears, and loose or missing hardware. If cracked, notify direct support maintenance for repair. If hardware is loose or missing, notify unit maintenance to tighten or replace it as necessary. c. Inspect for any chipped or missing paint and evidence of corrosion. If paint is damaged or access panel shows evidence of corrosion, notify direct support maintenance to paint it. 	Debris or foreign material obstructs the access panel openings.
16	Weekly	Heat Shield Gaskets	Inspect for loose or missing heat shield gasket and for splits or tears. If damaged or loose, notify unit maintenance to tighten or replace it as necessary.	

Table 2-1. Operator Preventive Maintenance Checks and Services - Continued

Item No	Interval	Location		Procedure	Not Fully Mission Capable If:
		Item to Check/ Service			
17	Weekly	Frame		<p>a. Inspect the frame for cracks and loose or missing hardware. If cracked, notify direct support maintenance for repair. If hardware is loose or missing, notify unit maintenance to tighten or replace it as necessary.</p> <p>b. Inspect the frame for any chipped or missing paint and evidence of corrosion. If paint is damaged or enclosure shows evidence of corrosion, notify direct support maintenance to paint it.</p> <p>c. Inspect the evaporator assembly condensate drain plastic tubing for any debris or foreign material obstructing it. Remove any debris or foreign material from the condensate drain tubing. If tubing cannot be cleaned, notify unit maintenance to clean it.</p> <p>d. Inspect for secure mounting to the refrigerator enclosure. If loose, notify unit maintenance to secure it.</p> <p>e. Inspect for missing or damaged mounting bolt assembly. If missing or damaged, notify unit maintenance to repair or replace it.</p>	<p>Debris or foreign material obstructing the condensate drain opening.</p> <p>Frame is loose on refrigerator enclosure.</p> <p>Unit mounting bolt is damaged or missing.</p>
		<u>Refrigeration Unit Interior</u>			
18	Weekly	Push (Door) Switches		<p>a. Inspect the push switches for cracked case and loose or missing attaching hardware. If damaged or loose, notify unit maintenance to tighten or replace it as necessary.</p>	<p>The push switches stick. Wire lead frayed or broken</p>

Table 2-1. Operator Preventive Maintenance Checks and Services - Continued

Item No	Interval	Location	Procedure	Not Fully Mission Capable If:
		Item to Check/ Service		
18 - Cont			<ul style="list-style-type: none"> b. Inspect the push switches for smooth operation. If binding, notify unit maintenance to test and replace it as necessary. c. Inspect the push switches for frayed or broken wire leads. If damaged, notify unit maintenance to repair or replace it as necessary. 	
19	Monthly	Refrigeration Unit Exterior Doors/Cover	<ul style="list-style-type: none"> a. Inspect the side and front doors and control. The side doors do not stay closed for any cracks, tears, and loose or missing hardware. If cracked, notify direct support maintenance for repair. If hardware is loose or missing, notify unit maintenance to tighten or replace as necessary. b. Inspect the doors and cover for any chipped or missing paint and evidence of corrosion. If paint is damaged or shows evidence of corrosion, notify direct support maintenance to paint it. c. Inspect the hinges for smooth operation and loose or missing attaching hardware. If hinges bind, notify unit maintenance to lubricate them. If attaching hardware is loose or missing, notify direct support maintenance to replace it. 	The side doors do not stay closed.
20	Monthly	Barrel Bolts	Inspect the barrel bolts for smooth operation and loose or missing attaching hardware. If barrel bolts bind, notify unit maintenance to lubricate them. If attaching hardware is loose or missing, notify unit maintenance to tighten or replace it as necessary.	

Table 2-1. Operator Preventive Maintenance Checks and Services - Continued

Item No	Interval	Location	Procedure	Not Fully Mission Capable If:
		Item to Check/ Service		
21	Monthly	Plates <u>Refrigeration Unit Interior</u>	Inspect for any damaged, loose, or missing information plates and loose or missing attaching hardware. If information plates are damaged or loose, notify direct support maintenance to tighten or replace them as necessary. <div style="text-align: center;">WARNING</div> High voltage and exposed rotating parts are contained in the refrigeration unit. Personal injury can result if power is connected.	
22	Monthly	Dehydrator	Inspect the dehydrator for damage or evidence of refrigerant leak. If damaged or evidence of leaking found, notify direct support maintenance to replace it	Dehydrator is damaged or evidence of leak is found.
23	Monthly	Receiver	Inspect the receiver for damage and evidence of refrigerant leak. Inspect the isolation valves for evidence of refrigerant leak. If damaged or evidence of leaking found, notify direct support maintenance to replace it.	Receiver is damaged or evidence of leak is found.
24	Monthly	Pressure Regulator Valves	Inspect the pressure regulator valves for damage or evidence of refrigerant leak. If damaged or evidence of leaking found, notify direct support maintenance to replace it.	Pressure regulator valve damaged or evidence of leak is found.
25	Monthly	Metal Hose Assemblies	Inspect the metal hose assemblies for kinks or evidence of refrigerant leak. If damaged or evidence of leaking found, notify direct support maintenance to replace it.	Metal hose assembly kinked or evidence of leak is found.
26	Monthly	Valves	Inspect the valves for evidence of refrigerant leak. If evidence of leaking found, notify direct support maintenance to replace it.	Evidence of leak is found.

Table 2-1. Operator Preventive Maintenance Checks and Services - Continued

Item No	Interval	Location	Procedure	Not Fully Mission Capable If:
		Item to Check/ Service		
27	Monthly	Solenoid Valves/Coils	Inspect the solenoid valves for frayed or broken wire leads, loose coil, loose or missing cover, and evidence of refrigerant leak. If coil is loose or damaged or wire leads are frayed or broken, notify unit maintenance to repair or replace it as necessary. If evidence of leaking found, notify direct support maintenance to replace it.	Wire lead frayed or broken, coil loose, or evidence of leak is found.
28	Monthly	Accumulator	Inspect the accumulator for damage and evidence of refrigerant leak. If damaged or evidence of leaking found, notify direct support maintenance to replace it.	Accumulator is damaged or evidence of leak is found.
29	Monthly	Pressure Switches	Inspect the pressure switches for frayed or broken wire leads and dented, loose, or missing cover. Inspect for evidence of refrigerant leak. If cover is loose or wire leads are frayed or broken, notify unit maintenance to repair or replace it as necessary. If damaged or evidence of leaking found, notify direct support maintenance to replace it.	Wire lead frayed or broken, cover missing, or evidence of leak is found.
30	Monthly	Compressor	Inspect the compressor for frayed or broken wire leads and loose or missing terminal cover. Inspect the sight glass for cracks. Inspect for evidence of refrigerant leak. Inspect shut off valves for evidence of refrigerant leak. If wire leads are frayed or broken, notify unit maintenance to repair or replace as necessary. If damaged or evidence of leaking found, notify direct support maintenance to repair or replace as necessary.	Wire lead frayed or broken, cover missing, sight glass cracked or evidence of leak is found.
31	Monthly	Strainer	Inspect the strainer for damage or evidence of refrigerant leak. If damaged or evidence of leaking found, notify direct support maintenance to replace it.	Strainer is damaged or evidence of leak is found.

SECTION III OPERATION UNDER USUAL CONDITIONS**2-4. ASSEMBLY AND PREPARATION FOR USE.**

The refrigeration unit requires specialized unpacking ,installation, and power connection procedures. Notify unit maintenance for installation.

2-5 . STARTUP PROCEDURES.

(See fig. 2-4.)

CAUTION

Operating the refrigeration unit with the service valves improperly set will damage the equipment. Do not operate unless you are sure it has been properly set up for operation. Notify unit maintenance.

- a . Be sure the refrigeration unit is connected to an active source of 208/230 Vac, 3 phase, 50/60 Hz electric power.

NOTE

Push switches in the side condenser door frames will prevent the refrigeration unit from operating if the side doors are open.

- b. Be sure both side condenser doors (1) are closed and secured.
- c. Set the remote bulb thermostat (TEMPERATURE CONTROL) (2) to the desired refrigerator enclosure temperature.
- d. Place the circuit breaker handle (3) in the ON position.
- e. Place the toggle switch (START/RUN, OFF) (4) handle in the START/RUN position.

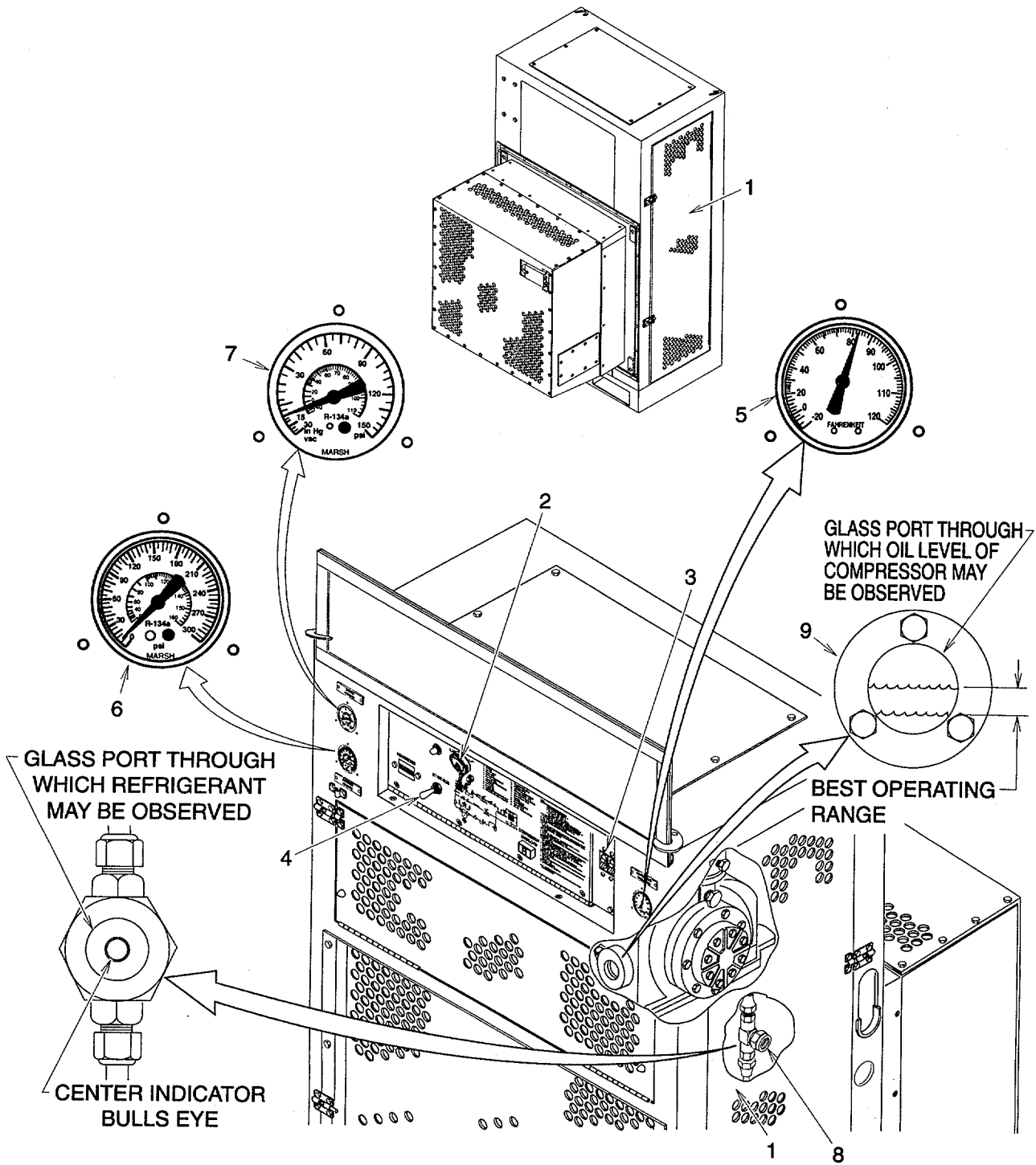

Figure 2-4. Operating Controls and Indicators

2-6. OPERATOR CHECKS.

(See fig. 2-4.)

NOTE

All checks must be performed when the DEFROST IN PROGRESS indicator is off.

- a. Check the thermometer (REFRIGERATION TEMPERATURE) (5) periodically to be sure it is within 15° F (70 C) of the temperature set on the remote bulb thermostat (TEMPERATURE CONTROL) (2).
- b. Check the pressure gage (DISCHARGE PRESSURE) (6) periodically to be sure it is between 160 and 270 psi (1104 and 1863 kPa).
- c. Check the compound gage (SUCTION PRESSURE) (7) periodically to be sure it is between 0 and 15 psi (0 and 104 kPa).

NOTE

An occasional flash of bubbles in the sight indicator (SIGHT GLASS) port is normal. The sight indicator can be viewed looking through the side condenser door.

- d. Check the sight indicator (SIGHT GLASS) (8) port to be sure it is clear. The center indicator should be green or chartreuse in color.

NOTE

Occasional bubbles in the compressor sight glass oil is normal. The sight glass can be viewed looking through the front top panel.

- e. Check the compressor sight glass (9) port to be sure the oil is clear and the level is between 1/4 and 1/2 up the port.

2-7. SHUTDOWN PROCEDURES.

(See fig. 2-4.)

NOTE

If the refrigeration unit is to be left off for several days, it must be pumped down
Notify Unit Maintenance.

- a. Place the toggle switch (START/RUN, OFF) (4) handle in the OFF position.
- b. Place the circuit breaker handle (3) in the OFF position.
- c. Notify unit maintenance if the refrigeration unit is to be put into administrative storage for several days.

2-8. DECALS AND INSTRUCTION PLATES.

Decals and instruction plates are illustrated in the following figure.

2-8. DECALS AND INSTRUCTION PLATES. - Continued

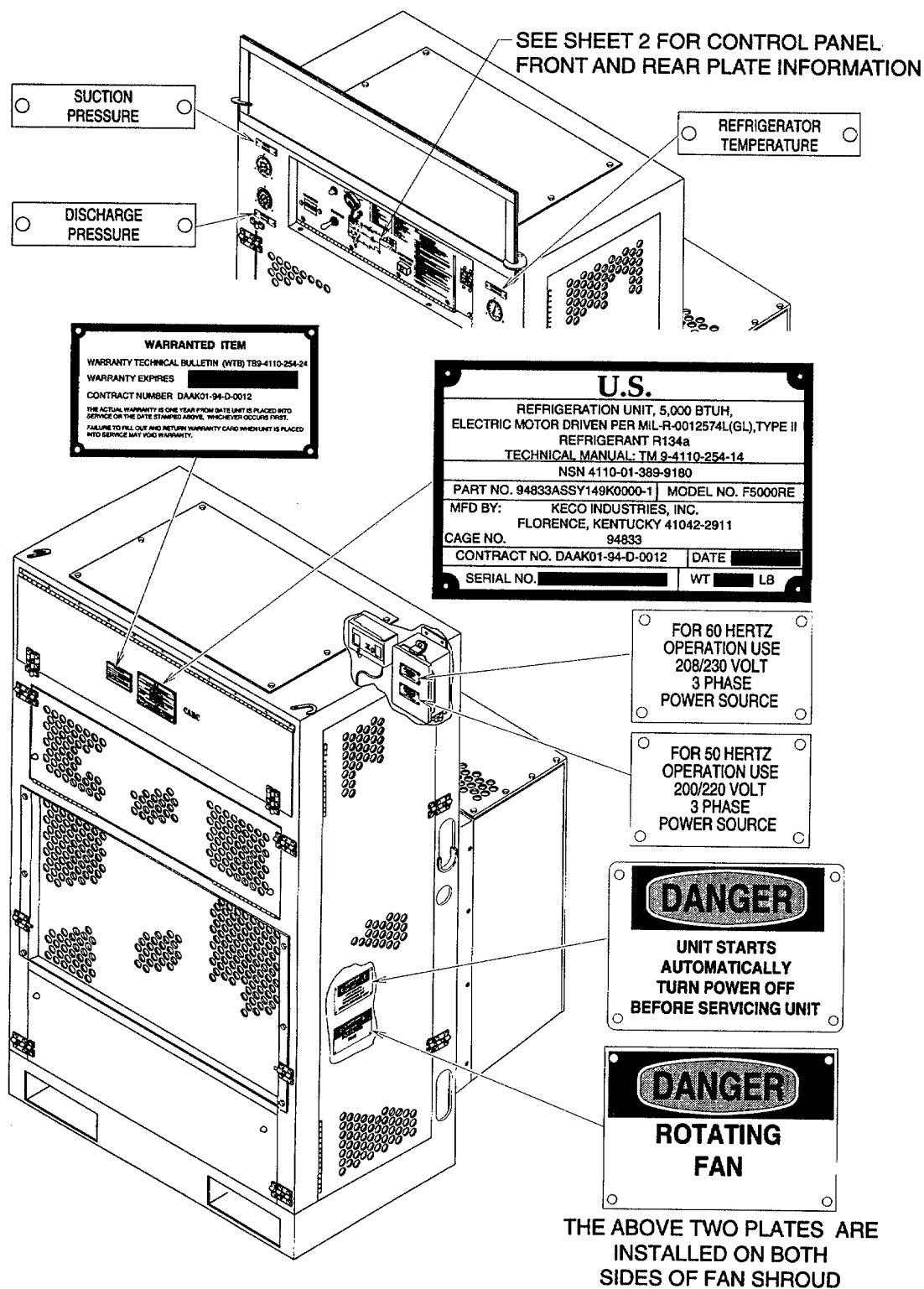
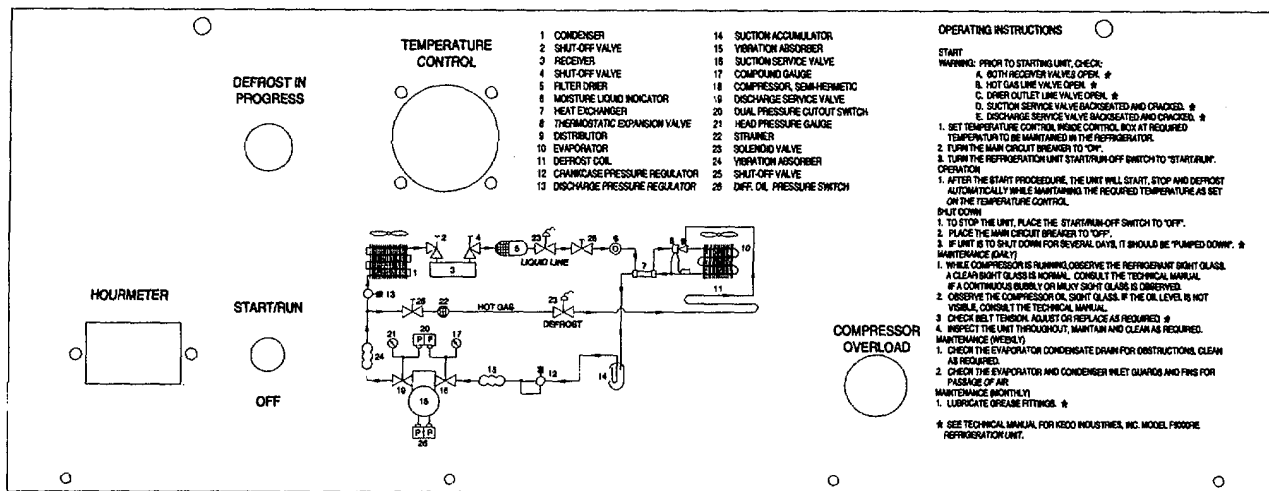
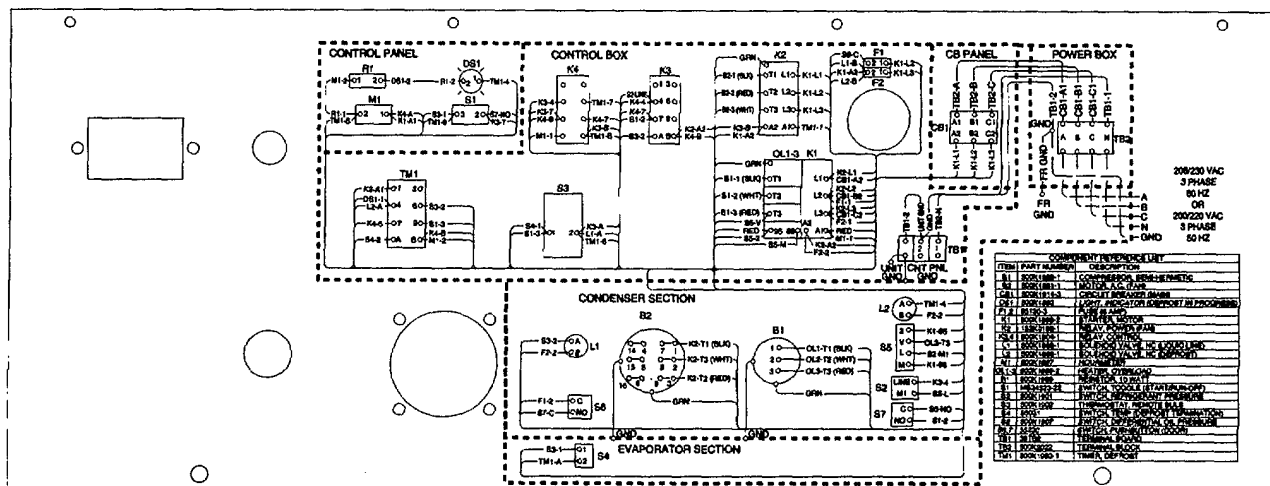

Figure 2-5. Decals and Instruction Plates (Sheet 1 of 2)



CONTROL PANEL FRONT



CONTROL PANEL REAR

Figure 2-5. Decals and Instruction Plates (Sheet 2 of 2)

SECTION IV OPERATION UNDER UNUSUAL CONDITIONS2-9. OPERATION UNDER INCLEMENT WEATHER.

The refrigeration unit is designed to operate under adverse conditions and does not require additional precautions or procedures.

2-10. NBC DECONTAMINATION PROCEDURES.

The following emergency procedures can be performed until field NBC decon facilities are available. If NBC attack is known or suspected, mask at once and continue mission. If outside, follow decon procedures below to avoid taking contamination into controlled area. Do not unmask until told to do so.

NOTE

Detailed decontamination procedures can be found in: FM 3-3, FM 3-4, and FM 3-5.

- a. Nuclear Decontamination. Brush fallout from skin, clothing and equipment with available brushes, rags, and tree branches. Wash skin and have radiation check made when tactical situation permits.
- b. Biological Decontamination. Remain masked and continue mission until told to unmask.
- c. Chemical Detection and Decontamination.

WARNING

Some decontamination sprays can cause personal injury and should not be used on personnel.

- (1) Contact your local chemical detachment or unit for proper use of decontamination equipment.
- (2) If exposure to liquid agent is known or suspected, clean exposed skin, clothing, personal gear, and equipment, in that order, using M258A1 kit. Use the buddy system. Wash exposed skin and thoroughly decontaminate when tactical situation permits.
- (3) Use M8 paper from the M256 Chemical Agent Detector Kit or M9 paper to determine if liquid agent is present on the equipment.
- (4) If the M8 or M9 paper indicates that liquid chemical agent is present on the equipment, use the NBC-M11 decon apparatus to decon equipment.

CHAPTER 3
OPERATOR MAINTENANCE INSTRUCTIONS

			Page
Section I		LUBRICATION	3-1
	3-1	Lubrication.....	3-1
Section II		TROUBLESHOOTING PROCEDURES	3-2
	3-2	Troubleshooting.....	3-2
Section III		OPERATOR'S MAINTENANCE PROCEDURES	3-5
	3-3	General	3-5
	3-4	Cleaning	3-5

SECTION I LUBRICATION

3-1. LUBRICATION.

Operator lubrication not required.

SECTION II TROUBLESHOOTING PROCEDURES

3-2. TROUBLESHOOTING.

The following procedures are listed in order of the most probable malfunctions. Each malfunction is followed by test or inspection procedures in logical order to isolate and identify the fault and actions required to correct it. This section cannot list all the possible malfunctions that may occur with the equipment .If a malfunction occurs that is not listed or actions listed do not correct a malfunction, notify your supervisor.

MALFUNCTION INDEX

	Troubleshooting Procedure Para
Refrigeration unit does not start	3-2, a.
Thermometer indicates more than 15° F (7° C) above remote bulb thermostat setting	3-2, b.
Pressure Gage (DISCHARGE) indicates above 270 psi (1863 kPa).....	3-2, c.
Pressure Gage (DISCHARGE) indicates below 160 psi (1104 kPa).....	3-2, d.
Pressure Gage (SUCTION) indicates above 15 psi (104 kPa)	3-2, e.
Pressure Gage (SUCTION) indicates below 0 psi (0 kPa)	3-2, f.

a. Refrigeration Unit Does Not Start.

IS POWER SOURCE CONNECTED AND ACTIVE?

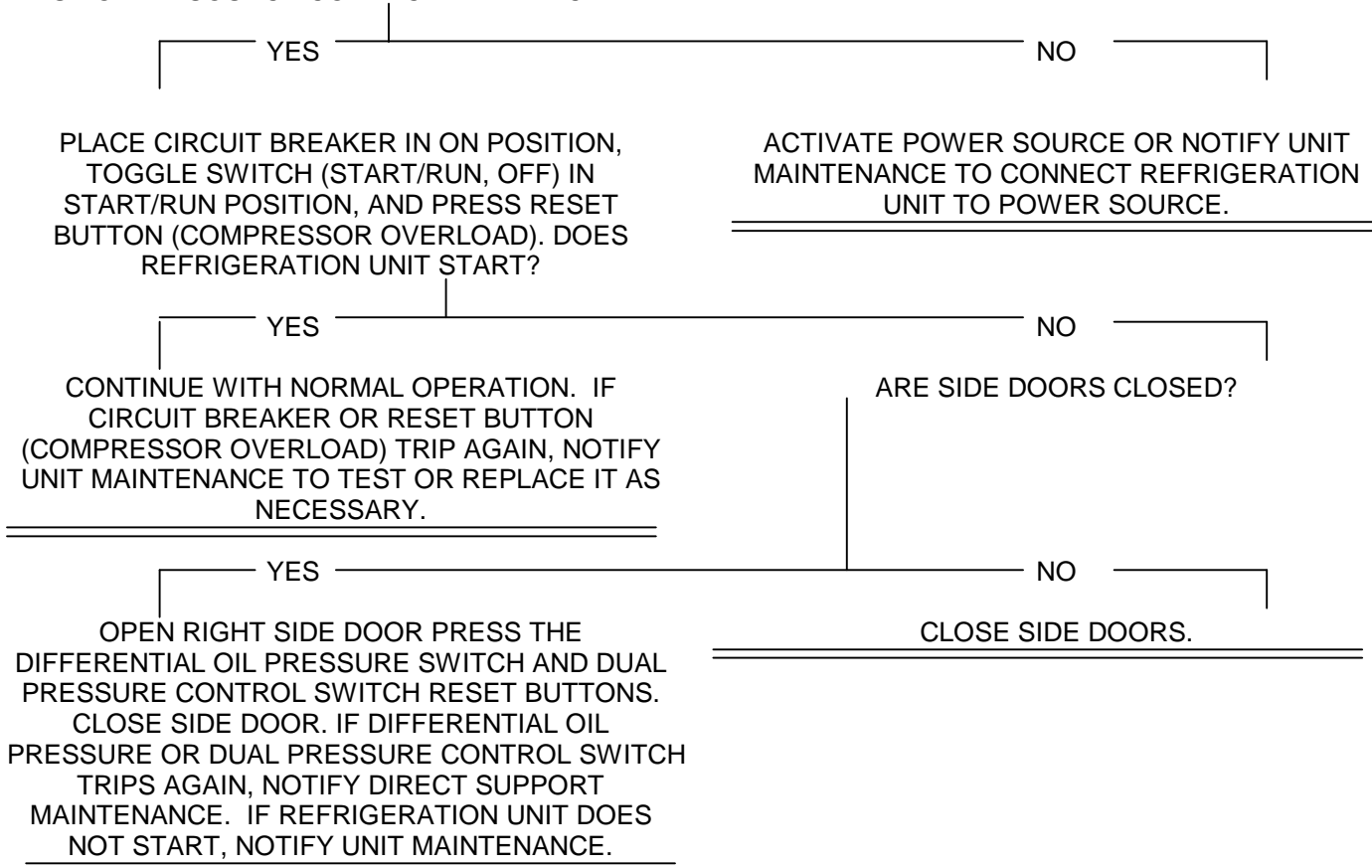

b. Thermometer Indicates More Than 15° F (7° C) Above Remote Bulb Thermostat Setting.

IS THE REFRIGERATION UNIT RUNNING?

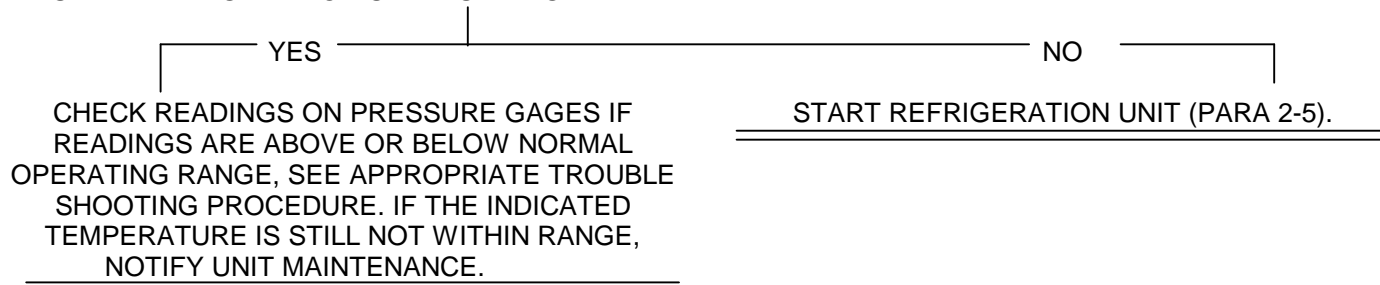

- c. Pressure Gage (DISCHARGE) Indicates Above 270 psi (1863 kPa). At start up and/or operation in high ambient temperatures, pressures above 270 psi (1863 kPa) are possible.

IS THE CONDENSER COIL GUARD OBSTRUCTED?

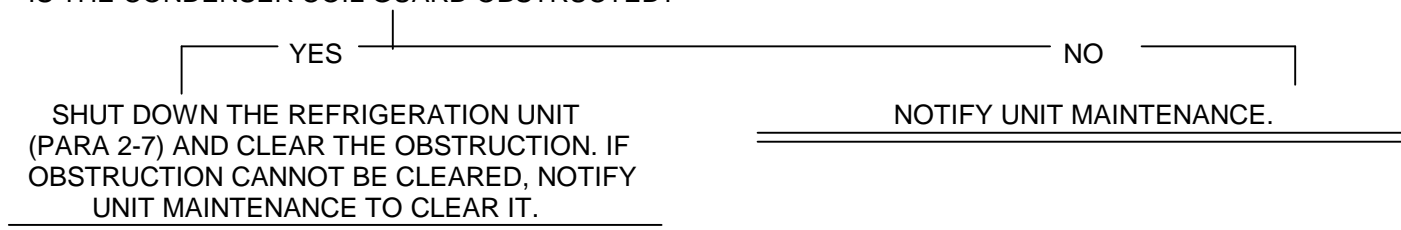

- d. Pressure Gage (DISCHARGE) Indicates Below 160 psi (1104 kPa). During operation in low ambient temperatures, pressures below 160 psi (1104 kPa) are possible.

NOTIFY UNIT MAINTENANCE.

- e. Pressure Gage (SUCTION) Indicates Above 15 psi (104 kPa). At start up and/or operation in high ambient temperatures, pressures above 15 psi (104 kPa) are possible.

IS REFRIGERATOR ENCLOSURE DOOR OPEN?

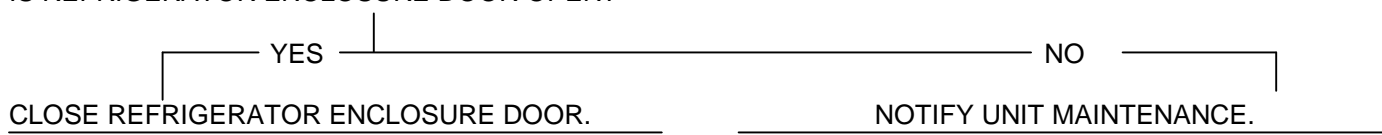

- f. Pressure Gage (SUCTION) Indicates Below 0 psi (0 kPa). At start up, shut down, or operation in low ambient temperatures, pressures below 0 psi (0 kPa) are possible.

IS THE EVAPORATOR COVER PANEL OBSTRUCTED?

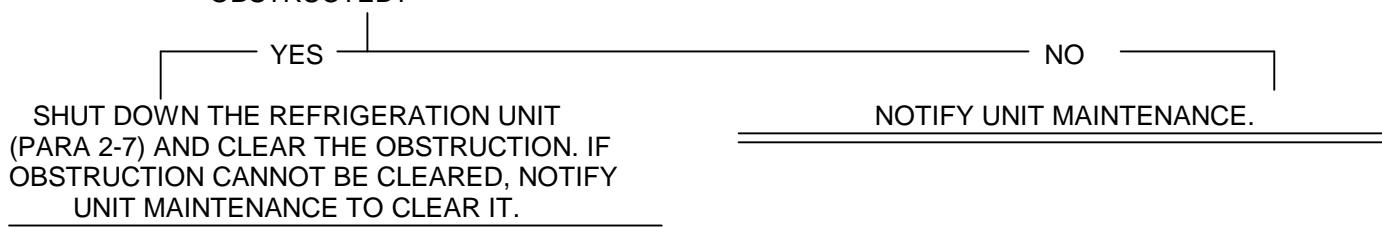

SECTION III OPERATOR'S MAINTENANCE PROCEDURES

INDEX

	Para
ENCLOSURE	
General	3-3
Cleaning	3-4

3-3. GENERAL.

With the exception of service and inspection procedures noted in the PMCS table 2-1, the following maintenance procedure is the only one authorized to the operator.

3-4. CLEANING.

This task covers: Cleaning

INITIAL SETUP

Equipment Conditions:

Refrigeration unit shut down (para 2-7).
Doors open as necessary.

General Safety Instructions:



High voltage and exposed rotating parts are contained in the refrigeration unit. Personal injury can result if power is connected.

Materials/Parts:

Detergent
 4, Appendix E
Rag
 3, Appendix E

Cleaning.

- (1) Mix a small quantity of detergent with clean water to make a wash solution.
- (2) Dampen a rag with wash solution and clean the equipment.
- (3) Dampen a rag with clean water and rinse the equipment. Rinse rag in clean water and continue until all detergent residue has been removed.
- (4) Wipe the equipment with a clean dry rag until thoroughly dry.

CHAPTER 4**UNIT MAINTENANCE INSTRUCTIONS****SECTION I REPAIR PARTS, TOOLS, SPECIAL TOOLS, TEST, MEASUREMENT,
AND DIAGNOSTIC EQUIPMENT (TMDE), AND SUPPORT EQUIPMENT****4-1. COMMON TOOLS AND EQUIPMENT.**

- a. For authorized common tools and equipment, refer to the Modified Table of Organization and Equipment (MTOE), CTA 50-970, or CTA 8-100, as applicable to your unit.
- b. The Shop Equipment (1), Automotive Vehicle (SC 4910-95-CL-A-74) will be used for all maintenance tasks. Any additional tools required for an individual maintenance task will be identified in the setup information for that task.

4-2. SPECIAL TOOLS, TMDE, AND SUPPORT EQUIPMENT.

- a. The Repair Parts and Special Tools List (RPSTL) (TM 9-4110-254-24P) as well as the Maintenance Allocation Chart (MAC) (appendix B) identify any tools and support equipment needed to maintain the refrigeration unit.
- b. There are no special or fabricated tools required to maintain the refrigeration unit.

4-3. REPAIR PARTS.

- a. Any mandatory replacement parts needed for the maintenance tasks are identified in the mandatory replacement parts list located in Appendix G.
- b. Repair parts are listed and illustrated in the repair parts and special tools list (TM 9-4110-254-24P) covering unit maintenance for this equipment.

SECTION II SERVICE UPON RECEIPT**4-4. SITE AND SHELTER REQUIREMENTS.**

- a. The refrigeration unit requires a source of 208/230 Vac, 50/60 Hz, 12 amp electric power connected directly to the input power enclosure assembly.
- b. The refrigerator enclosure must have an accessible wall area 35.0 in. (88.9 cm) wide and 56 5 in. (143.5 cm) high to accommodate the refrigeration unit.
- c. The refrigeration unit weighs 790 lb (358 Kg). The refrigerator enclosure wall must be strong enough to support this weight.

4-5. SERVICE UPON RECEIPT OF MATERIAL.

- a. Inspect the equipment for damage incurred during shipment. If the equipment has been damaged, report the damage on SF 364, Report of Discrepancy.
- b. Check the equipment against the packing slip to see if the shipment is complete. Report all discrepancies in accordance with the instructions of DA Pam 738-750.

4-6. INSTALLATION INSTRUCTIONS.

- a. Tools and Equipment. Tools required to install the refrigeration unit include a wrench for tightening the mounting hardware and a fork lift or similar lifting device.
- b. Refrigerator Enclosure Preparation. The refrigerator enclosure must have an opening 30.50 in (77.47 cm) wide and 28.00 in (71.12 cm) high (fig. 4-1) to insert the refrigeration unit. If an opening does not already exist in the enclosure, see the enclosure manual for information on making such an opening.

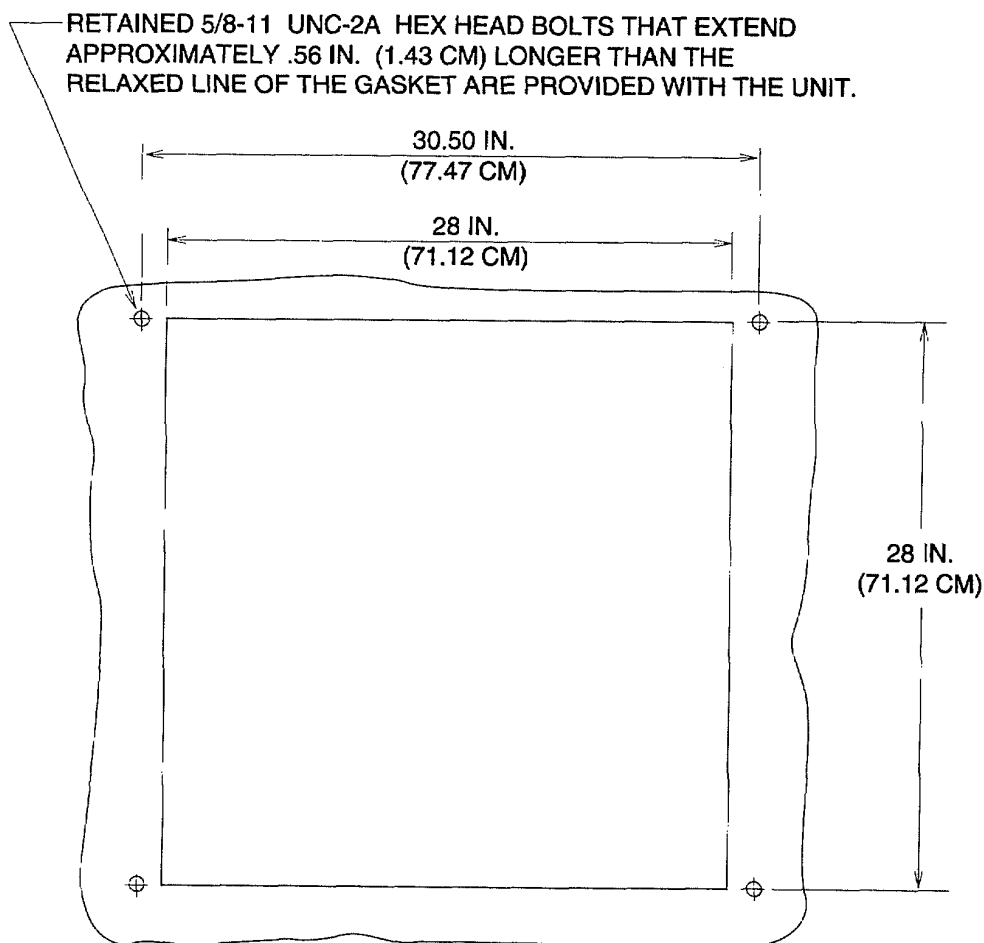

Figure 4-1. Wall Opening Dimensions

c. Installation. Using a fork lift or similar lifting device, lift the refrigeration unit, and carefully position the refrigeration unit into the refrigerator enclosure opening.

- (1) Secure the refrigeration unit to the refrigerator enclosure using mounting bolts provided.
- (2) Remove lifting device.

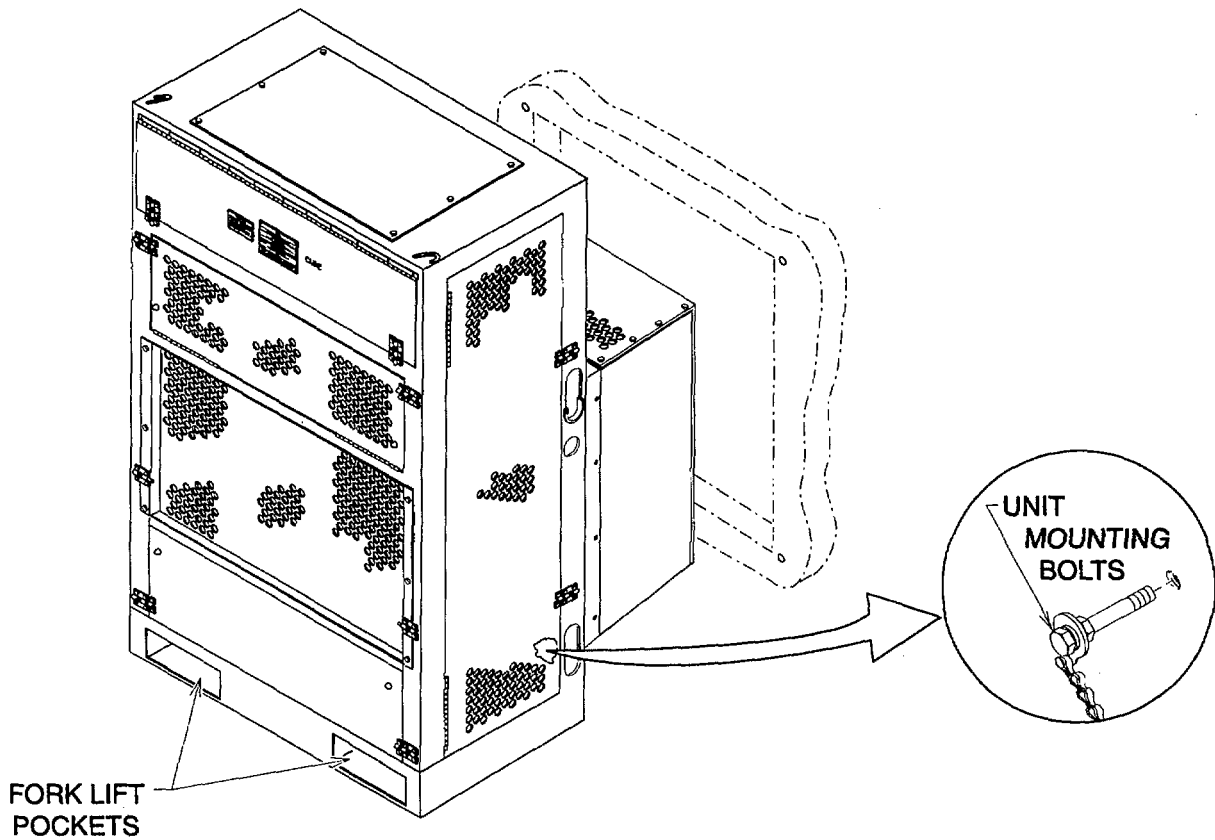

Figure 4-2. Installation

4-6. INSTALLATION INSTRUCTIONS. - Continued

d. Power Connection. The refrigeration unit must be connected to a four or five wire 208/230 Vac, 50/60 Hz, 12 amp source of electrical power.

- (1) Open right side door (1, fig. 4-3).
- (2) Loosen two screws (2) and open enclosure assembly door.

WARNING

High voltage can kill. Personal injury or death can occur if power is connected to input power cable when installing.

- (3) Be sure power is disconnected from input power cable Push cable through rubber grommet (3) then through cable strain relief bushing (4). Leave enough slack in cable wire leads to make connections to terminals and tighten bushing.

CAUTION

Operating the refrigeration unit prior to performing preliminary service, can cause equipment damage.

- (4) Connect wire leads to terminal block TB2 and GROUND inside enclosure assembly. When using only four wires, connect the fourth wire to GROUND and not neutral (N).

WARNING

High voltage will be exposed in enclosure assembly. Connecting power to the refrigeration unit with the enclosure assembly door open can cause personal injury or death.

- (5) Close enclosure assembly door and tighten two screws (2) to secure.
- (6) Close and secure right side door (1).

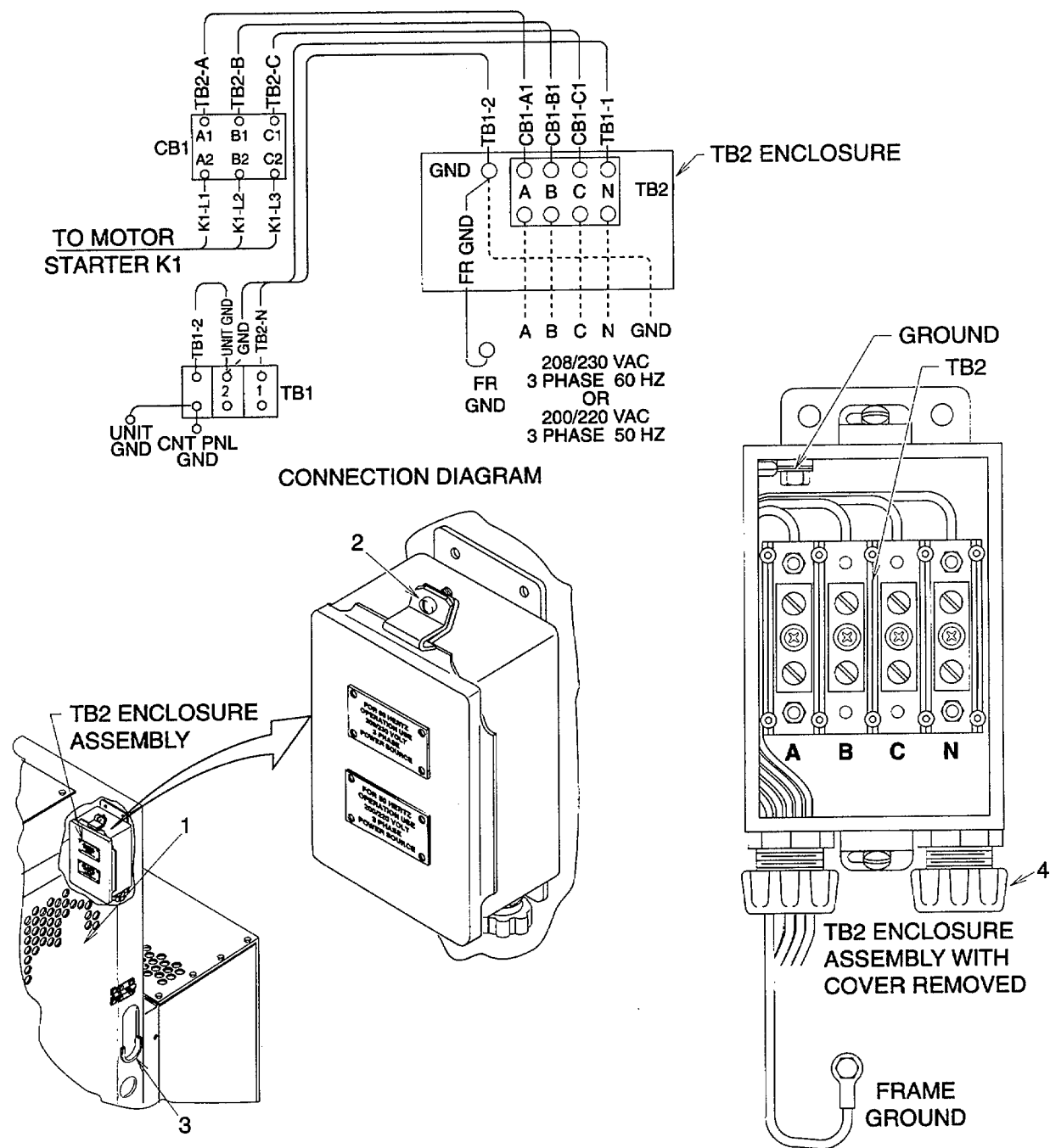

Figure 4-3. Input Power Connection

4-7. PRELIMINARY SERVICING OF EQUIPMENT.

- a. Open both side doors.

CAUTION

Using excessive force when opening or closing valves can cause damage to the valve seats.

- b. Fully open both stop valves (1, fig. 4-4) and (2).

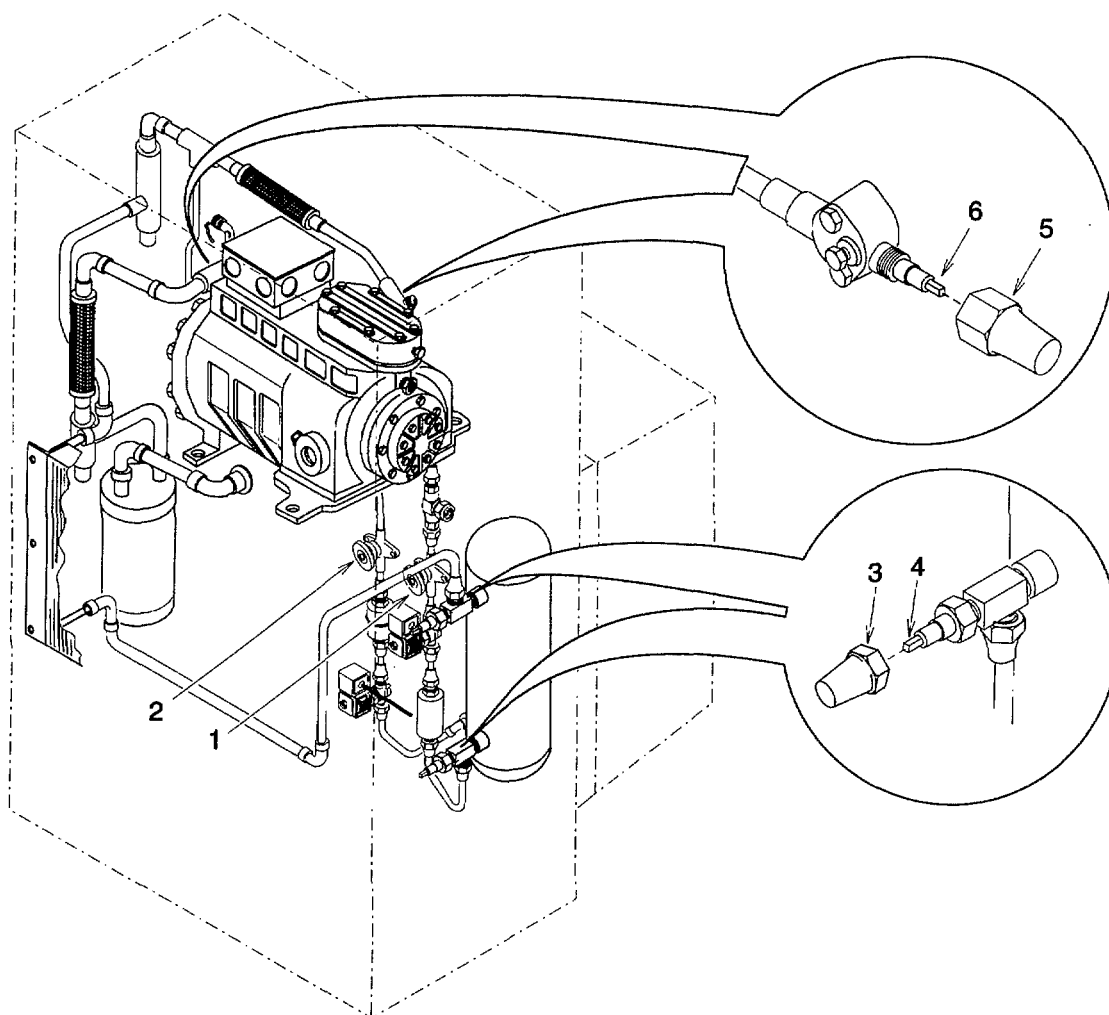

Figure 4-4. Refrigeration Valve Settings for Normal Operation

- c. Remove two caps (3) and fully open two isolation valves (4) Install two caps

NOTE

The compressor shut off valves can be adjusted to three positions, fully closed to block the refrigerant tubes and isolate the compressor and service port, fully open to allow flow from piping to compressor but not the service port, and cracked (one turn closed from fully open) to allow flow from piping to compressor and service port on valve

- d. Remove two caps (5) and fully open two shut off valves (6) Install two caps

- e. Loosen four compressor mount locknuts (1, fig 4-5) until proper operating space 1 5 in (3 81 cm) is reached Shipping bracket (2) must remain clipped to spring (3)

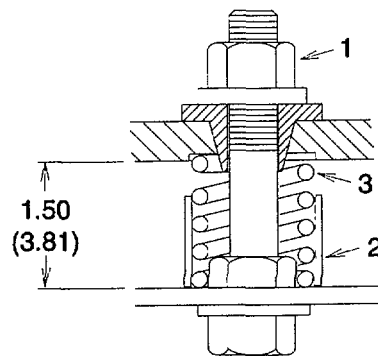

Figure 4-5. Compressor Mount

- f. Close both side doors.

4-8. PRELIMINARY ADJUSTMENT OF EQUIPMENT.

- a. Open control box cover door and secure open with door holder clips
- b. Remove two bolts (1, fig 4-6) and lock washers (2). Open the control panel (3). Discard lock washers

4-8. PRELIMINARY ADJUSTMENT OF EQUIPMENT. - Continued

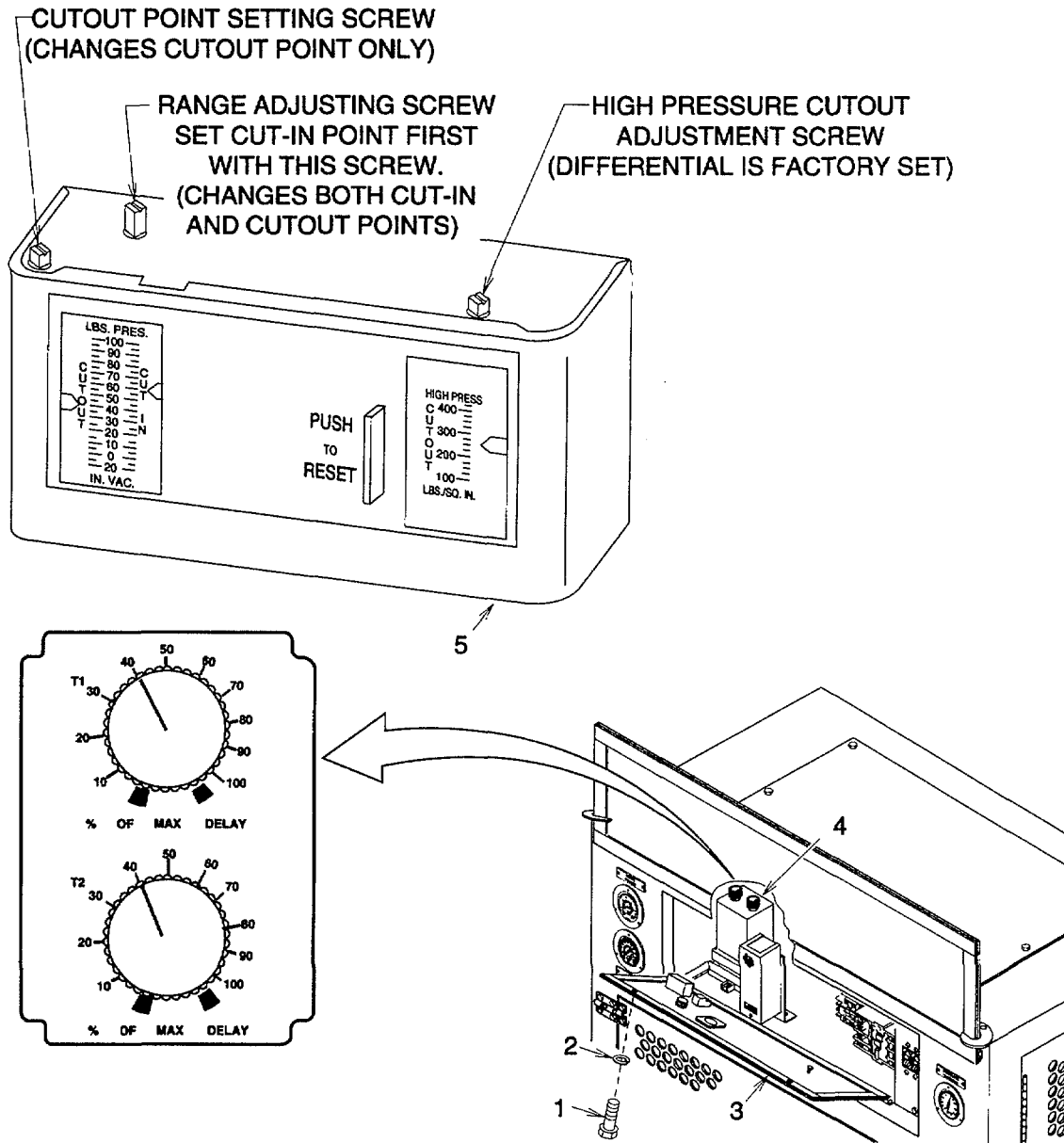

Figure 4-6. Preliminary Adjustment

NOTE

- The repeat cycle timer controls are marked T1 and T2. Control T1 adjusts the length of time the refrigeration unit will operate continuously before initiating a defrost cycle. Control T2 adjusts the maximum length of time the refrigeration unit will remain in the defrost cycle
- The timer scales indicate an approximate percentage of time based on 24 hours. For example, to set the timer for 6 hours, adjust the control to 25% (6 hours is 25% of 24 hours).
- The timer controls have a minimum setting of 14 minutes when set at 0%.

c. Adjust the repeat cycle timer (4) control T1 to approximately 25% (6 hours) and control T2 to approximately 2% (30 minutes). This is the recommended factory setting, however, the controls can be set as desired to best suit the operating conditions.

d. Close the control box panel (3). Install two bolts (1) with new lock washers (2) (1, appendix G).

e. Close and secure the control box cover.

f. Open right side door.

g. Adjust dual pressure control switch (5) HIGH PRESSure CUTOUT to 305, low pressure CUT IN to 0, and low pressure CUTOUT to 15 IN. VAC.

h. Close right side door

SECTION III UNIT PREVENTIVE MAINTENANCE CHECKS AND SERVICES (PMCS)

4-9. LUBRICATION

The lubrication instructions and hardtime intervals contained in figure 4-7 are mandatory. This refrigeration unit is not enrolled in the Army Oil Analysis Program. **HARDTIME INTERVALS APPLY.**

4-10. GENERAL

Preventive Maintenance Checks and Services (PMCS) are essential to the efficient operation of the refrigeration unit and to prevent possible damage that might occur through neglect or failure to observe warning symptoms in a timely manner. Intervals are determined by hours of operation expressed in applicable units of measure. The Preventive Maintenance Checks and Services Table 4-1 lists procedures done first or most frequently.

a. Warnings and Cautions. Always observe the warnings and cautions appearing in your PMCS Table. Warnings and cautions appear before applicable procedures. You must observe these warnings and cautions to prevent serious injury to yourself and others or prevent your equipment from being damaged.

b. Explanation of Table Entries.

(1) Item Number Column. Numbers in this column are for reference. When completing DA Form 2404 (Equipment Inspection and Maintenance Worksheet), include the item number for the check/service indicating a fault. Item numbers also appear in the order that you must do checks and services for the intervals listed.

(2) Interval Column. This column tells you when you must do the procedure in the procedure column **BEFORE** procedures must be done before you operate or use the equipment for its intended mission **DURING** procedures must be done during the time you are operating or using the equipment for its intended mission. **AFTER** procedures must be done immediately after you have operated or used the equipment. When a check and service procedure is required for both **WEEKLY** and **BEFORE** intervals, it is not necessary to do the procedure twice if the equipment is operating during the **WEEKLY** period.

(3) Location. Check/Service Column. This column provides the location and the item to be checked or serviced. The item location is underlined.

(4) Procedure Column. This column gives the procedure you must do to check or service the item listed in the Check/Service column to know if the equipment is ready or available for its intended mission or for operation. You must do the procedure at the time stated in the interval column.

(5) Not Fully Mission Capable If: Column. Information in this column tells you what faults will keep your equipment from being capable of performing its primary mission. If you made a check and service procedure that shows faults listed in this column, do not operate the equipment. Follow standard operating procedures for maintaining the equipment or reporting equipment failure.

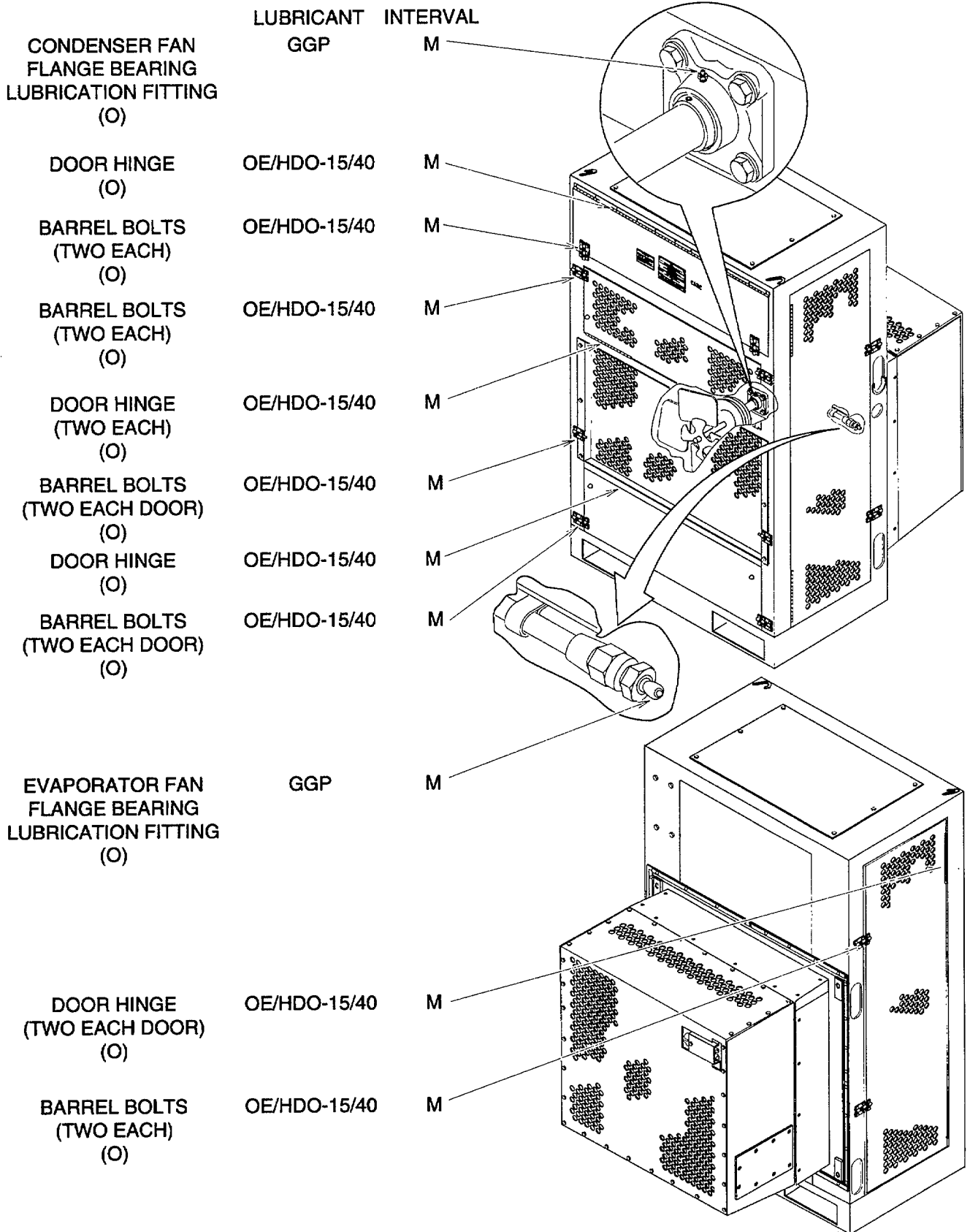

Figure 4-7. Lubrication

4-10 GENERAL. - Continued

c. Special Information Paragraphs

(1) Corrosion Prevention Control. If a corrosion problem is identified, it can be reported using Standard Form 368, Production Quality Deficiency Report. The form should be submitted to the address specified in DA Pam 738-750. This will result in more definitive actions be taken to prevent future occurrences.

(2) Leakage Definition for Unit PMCS. It is necessary for you to know how fluid leakage affects the status of your refrigeration unit. Oil is carried with the refrigerant as it flows through the refrigeration system. If a leak develops in the system, the oil will seep out and soak the copper tubing around the leak or drip and soak or puddle on the frame or other component below the leak. If any oil or seepage is found, a refrigerant leak would be suspected.

(a) Class I is defined as seepage of fluid (as indicated by wetness or discoloration) but not great enough to form drops.

(b) Class II is defined as leakage of fluid great enough to form drops but not enough to cause drops to drip from item being checked/inspected.

(c) Class III is defined as leakage of fluid great enough to form drops that fall from item being checked/inspected.

INITIAL SETUP

Tools:

Fin Comb
2, Section III, Appendix B

General Safety Instructions:

WARNING

High voltage and exposed rotating parts are contained in the refrigeration unit. Personal injury can result if power is connected.

Materials/Parts:

Wiping Rag
3, Appendix E
Detergent
4, Appendix E
General Purpose Lubricating Oil
5, Appendix E
Multipurpose Grease
6, Appendix E

Table 4-1. Unit Preventive Maintenance Checks and Services for Model F5000RE

NOTE

If the equipment must be kept in continuous operation, do only the procedures that can be done without disturbing operation. Make complete checks and services when the equipment is shut down

Item	Interval	Location	Procedure	Not Fully Mission Capable If:
		Item to Check/Service		
1	Monthly	<u>Refrigeration Unit Exterior</u>	Service the doors and cover by lubricating the hinges (fig. 4-7) <ul style="list-style-type: none"> a. Apply lubricating oil (MIL-L-2104) sparingly from oil can onto the hinge moving joint surfaces. b. Wipe away excess lubricating oil with a clean rag. 	
		Doors/Cover		
2	Monthly	Grommet (Input Cable)	Check that grommet is in place and not cracked or split. Replace if missing or damaged (figure F-4, Appendix F).	
3	Monthly	Barrel Bolts	Service the barrel bolts by lubricating them (fig. 4-7). <ul style="list-style-type: none"> a. Apply lubricating oil (MIL-L-2104) sparingly from oil can onto the barrel bolt moving joint surfaces. b. Wipe away excess lubricating oil with a clean rag. 	
4	Monthly	Condenser Coil	<ul style="list-style-type: none"> a. Inspect as much of coil as possible, without disassembly, for any evidence of refrigerant leak. If evidence of leak is found, notify direct support maintenance to repair or replace it as necessary b. Inspect coil for obstructions. If coil is obstructed with dirt or fins are bent, remove coil guard (para 4-17) and clean or straighten fins as needed. 	Condenser coil is obstructed or evidence of leak is found

Table 4-1. Unit Preventive Maintenance Checks and Services for Model F5000RE - Continued

Item	Interval	Location	Procedure	Not Fully Mission Capable If:
		Item to Check/Service		

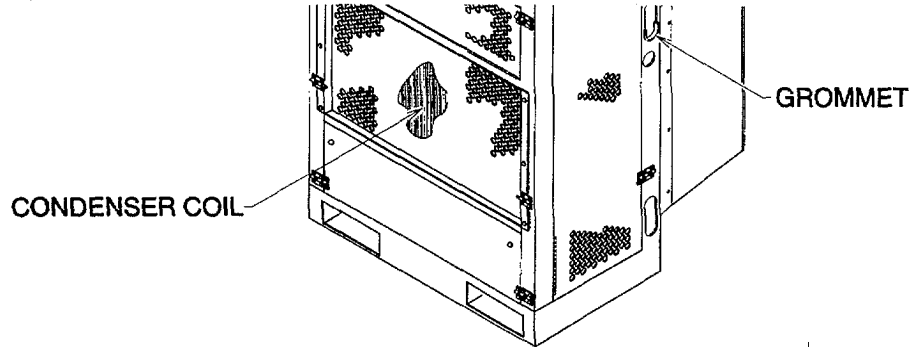

4- Cont			<ol style="list-style-type: none"> (1) Clean coil if dirty. <ol style="list-style-type: none"> (a) Mix a small quantity of detergent with water to make a wash solution (b) Dip a scrub brush in the wash solution and clean the fins by carefully brushing up and down. Continue to dip and brush as needed to loosen dirt (c) Rinse the scrub brush with clean water and rinse the fins by carefully brushing up and down. Continue to rinse and brush as needed to clean the coil (2) If fins are bent, carefully straighten them using fin comb. (3) Install coil guard (para 4-17). 	
5	Monthly	Evaporator Coil	<ol style="list-style-type: none"> a. Inspect as much of coil as possible, without disassembly, for any evidence of refrigerant leak. If evidence of leak is found, notify direct support maintenance to repair or replace it as necessary. b. Inspect coil for obstructions. If coil is obstructed with dirt or bent fins, remove cover panel (para 4-16) and clean or straighten fins as needed. <ol style="list-style-type: none"> (1) Clean coil if dirty <ol style="list-style-type: none"> (a) Mix a small quantity of detergent with water to make a wash solution (b) Dip a scrub brush in the wash solution and clean the fins by carefully brushing up and down. Continue to dip and brush as needed to loosen dirt. 	Evaporator coil is obstructed or evidence of leak is found.

Table 4-1. Unit Preventive Maintenance Checks and Services for Model F500RE - Continued

Item	Interval	Location	Procedure	Not Fully Mission Capable If:
		Item to Check/Service		
			<p>(c) Rinse the scrub brush with clean water and rinse the fins by carefully brushing up and down. Continue to rinse and brush as needed to clean the coil.</p> <p>(2) If fins are bent, carefully straighten them using fin comb</p>	
				
6	Monthly	<p>Refrigeration Unit Interior</p> <p>Flange Bearings</p>	<p style="text-align: center;">NOTE</p> <p>The cover panel must be removed for the following monthly PMCS.</p> <ol style="list-style-type: none"> a. Remove cover panel (para 4-16) and inspect flange bearings for loose or missing mounting hardware and looseness of fan drive shaft in bearing. If loose, tighten or replace it as necessary (para 4-16). b. Service the flange bearings by lubricating them (fig. 4-7). <ol style="list-style-type: none"> (1) Wipe grease fitting with a clean rag. (2) Pump grease gun handle until a flow of clean grease (MIL-G-23549) comes out nozzle. (3) Attach grease gun nozzle to grease fitting and pump handle until grease just begins coming out around bearing. (4) Remove grease gun nozzle and wipe away excess grease with a clean rag. 	<p>Flange bearing mounts are loose or fan drive shaft is loose in bearing.</p>

Table 4-1. Unit Preventive Maintenance Checks and Services for Model F500RE - Continued

Item	Interval	Location	Procedure	Not Fully Mission Capable If:
		Item to Check/Service		



7	Monthly	Condenser and Evaporator Fans	<p>a. Inspect fans for cracks and tears. Inspect for loose connection to fan drive shaft. If loose, tighten to shaft. If damaged, replace (para 4-42, 4-43).</p> <p>b. Install cover panel (para 4-16).</p>	Fan is cracked, torn, or loose.
---	---------	-------------------------------	---	---------------------------------

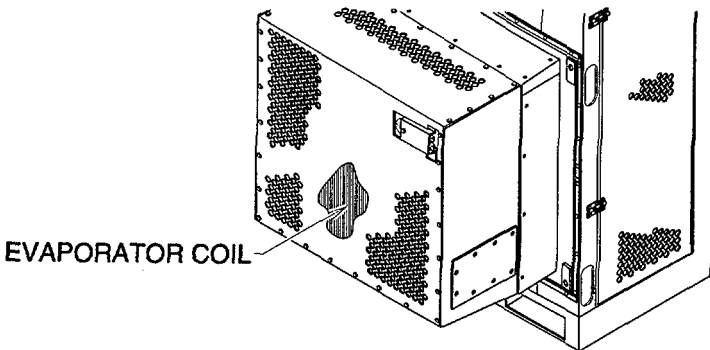
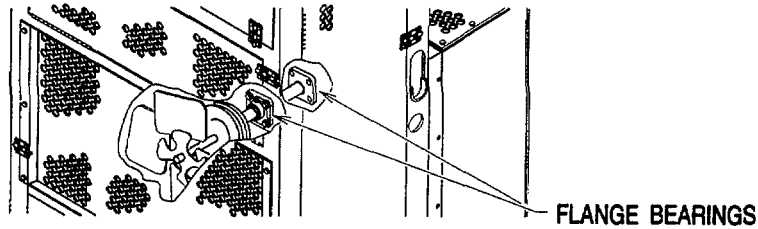
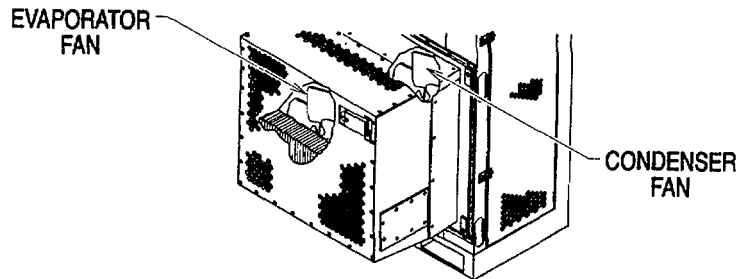

8	Semi-Annually	<p>Refrigeration Unit Interior</p> <p>AC Motor</p>	<p>Inspect AC motor for evidence of overheating in the form of discolored or blistered paint. Check for loose or missing mounting hardware and loose shaft. If evidence of overheating is observed or the shaft is loose, replace motor (para 4-41). If mounting hardware is loose or missing, tighten or replace as necessary (para 4-18).</p>	Evidence of overheating is found. Shaft is loose, mounting hardware is loose or missing.
---	---------------	--	---	--

Table 4-1. Unit Preventive Maintenance Checks and Services for Model F5000RE - Continued

Item	Interval	Location	Procedure	Not Fully Mission Capable If:
		Item to Check/Service		

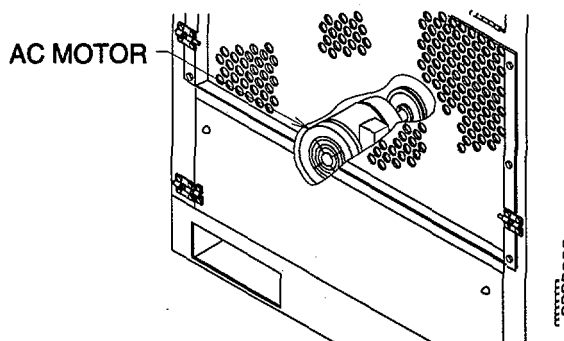

9	Semi-Annually	Control Box Interior	<p style="text-align: center;">NOTE</p> <p>The control box cover must be open, and the circuit breaker cover loose, for all interior control box PMCS.</p> <ol style="list-style-type: none"> a. Open the control panel (para 4-19) and remove the circuit breaker cover from the control box (para 4-21). Do not disconnect any wire leads. b. Check for loose or missing fuse block mounting hardware, loose wire leads, and loose fuse block clips. If mounting hardware or leads are loose, tighten or replace as necessary (para 4-24). If fuse block clips are loose, replace fuse block (para 4-24). c. Check each fuse for broken link or discoloration of case. Replace fuse if link is broken or case is discolored (para 4-24). 	Wire lead or fuse clip loose. Fuse link is broken or fuse case is discolored.
		Fuses		

Table 4-1. Unit Preventive Maintenance Checks and Services for Model F5000RE - Continued

Item	Interval	Location	Procedure	Not Fully Mission Capable If:
		Item to Check/Service		

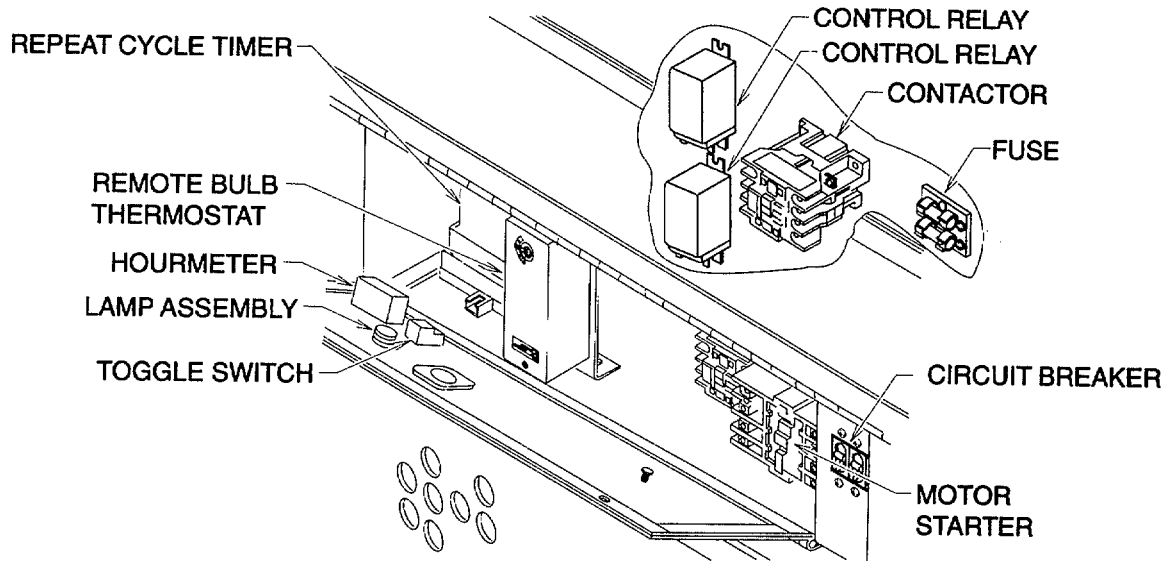

10	Semi-Annually	Lamp Assembly	Inspect the lamp assembly for cracked or missing cap, loose base, and loose wire leads Tighten cap if loose If damaged, wire leads are loose, or base is loose, test, tighten base or wire leads, or replace as necessary (para 4-23)	Wire leads are loose.
11	Semi-Annually	Hourmeter	Inspect the hourmeter for cracked or missing lens or any other damage and loose or missing mounting hardware and wire leads If damaged or wire leads or mounting hardware is loose, tighten, or replace as necessary (para 4-28) NOTE Operating the toggle switch can cause the refrigeration unit to start or shut down.	Wire leads are loose.
12	Semi-Annually	Toggle Switch	Inspect the toggle switch for any damage and loose or missing mounting hardware or wire leads Inspect for smooth operation to START/RUN and OFF. If damaged, or wire leads or mounting hardware is loose, or operation is stiff or binding, test, tighten, or replace as necessary (para 4-29).	Toggle switch will not stay in START/RUN position. Wire leads are loose.

Table 4-1. Unit Preventive Maintenance Checks and Services for Model F500RE - Continued

Item	Interval	Location	Procedure	Not Fully Mission Capable If:
		Item to Check/Service		
			NOTE	
			Operating the circuit breaker can cause the refrigeration unit to start or shut down.	
13	Semi-Annually	Circuit Breaker	Inspect the circuit breaker for any damage and loose or missing mounting hardware or wire leads. Inspect for smooth operation to ON and OFF. If damaged, or wire leads or mounting hardware is loose, or operation is stiff or binding, test, tighten, or replace as necessary (para 4-21).	Circuit breaker will not stay in ON position or handle is damaged. Wire leads are loose.
14	Semi-Annually	Motor Starter	<ul style="list-style-type: none"> a. Check for loose or missing mounting hardware and wire terminals. Tighten or replace as necessary (para 4-25). b. Inspect case for cracks, breaks, or evidence of overheating. Replace if damaged (para 4-25). 	Mounting hardware or wire terminals are loose. Case is damaged.
15	Semi-Annually	Control Relays	<ul style="list-style-type: none"> a. Check for loose or missing mounting hardware and wire terminals. Tighten or replace as necessary (para 4-27). b. Inspect case for cracks, breaks, or evidence of overheating. Replace if damaged (para 4-27). 	Mounting hardware or wire terminals are loose. Case is damaged.
16	Semi-Annually	Contactors	<ul style="list-style-type: none"> a. Check for loose or missing mounting hardware and wire terminals. Tighten or replace as necessary (para 4-26). b. Inspect case for cracks, breaks, or evidence of overheating. Replace if damaged (para 4-26). 	Mounting hardware or wire terminals are loose. Case is damaged.

Table 4-1. Unit Preventive Maintenance Checks and Services for Model F5000RE - Continued

Item	Interval	Location	Procedure	Not Fully Mission Capable If:
		Item to Check/Service		
17	Semi-Annually	Repeat Cycle Timer	<ul style="list-style-type: none"> a. Check for loose or missing mounting socket hardware and wire terminals. Tighten or replace as necessary (para 4-30). b. Inspect case and mounting socket for cracks, breaks, or evidence of overheating. Replace if damaged (para 4-30). c. Check and adjust the timer controls if needed (para 4-30). 	Mounting hardware or wire terminals are loose. Case is damaged.
18	Semi-Annually	Remote Bulb Thermostat	<ul style="list-style-type: none"> a. Check for loose or missing mounting hardware and wire terminals Tighten or replace as necessary (para 4-31). b. Inspect for kinked or broken sensing bulb capillary line If damaged, replace thermostat (para 4-31). c. Install the circuit breaker cover onto the control box (para 4-21) Close the control panel (para 4-19). <p style="text-align: center;">NOTE</p> <p>The cover panel must be removed for the following semi-annual PMCS</p>	Sensing bulb capillary line is kinked or broken. Mounting hardware or wire terminals are loose.
		<u>Refrigeration Unit Exterior</u>		
19	Semi-Annually	Defrost Termination Thermostat	<ul style="list-style-type: none"> a. Remove the access panel (para 4-15) and cover panel (para 4-16). b. Inspect for frayed or broken wire leads. If damaged, repair or replace as needed (para 4-51). c. Check that the switch is in contact with the tubing. Tighten if loose. 	Wire lead frayed or broken. Temperature switch loose on tubing loose.

Table 4-1. Unit Preventive Maintenance Checks and Services for Model F5000RE - Continued

Item	Interval	Location	Procedure	Not Fully Mission Capable If:
		Item to Check/Service		

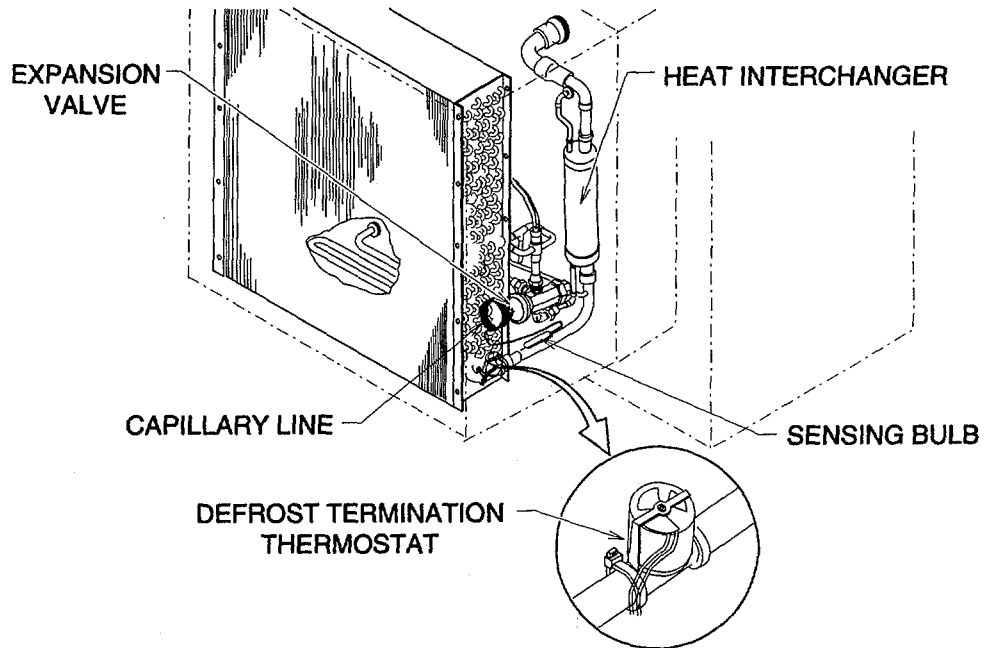

20	Semi-Annually	Heat Interchanger	Inspect the heat interchanger for dents or evidence of refrigerant leak. If damaged or evidence of leaking found, notify direct support maintenance to replace it.	Heat interchanger is dented or evidence of leak is found
21	Semi-Annually	Tubing and Fittings	Inspect the tubing and fittings for kinks, restriction (crushed), or evidence of refrigerant leak. If damaged or evidence of leaking found, notify direct support maintenance to tighten, repair, or replace as necessary.	Tubing or fittings damaged, kinked, or evidence of leak is found.
22	Semi-Annually	Expansion Valve	<ol style="list-style-type: none"> a. Inspect the expansion valve for evidence of refrigerant leak. If evidence of leak is found, notify direct support maintenance to replace it. b. Inspect the sensing bulb capillary line for cracks, kinks, or breaks. If damaged, notify direct support maintenance to replace the expansion valve. 	Evidence of leak is found, sensing bulb is loose on tubing, or capillary line is kinked or broken.

Table 4-1. Unit Preventive Maintenance Checks and Services for Model F5000RE - Continued

Item	Interval	Location	Procedure	Not Fully Mission Capable If:
		Item to Check/Service		
22 - Cont	Annually	Refrigeration Unit Interior	<p>c Check that the sensing bulb mounting hardware is secure and the bulb is in contact with the tubing. Tighten the mounting hardware if loose.</p> <p>d Install cover panel (para 4-16) and access panel (para 4-15)</p>	Wire lead frayed or broken.
23		Wires, Cables, and Harnesses	<p>a. Remove the access panel (para 4-15).</p> <p>b. Open the control panel (para 4-19) and remove the circuit breaker cover from the control box (para 4-21). Do not disconnect any wire leads.</p> <p>c. Inspect for frayed or broken wire leads. If damaged, repair or replace as needed (para 4-20)</p> <p>d. Install the circuit breaker cover onto the control box (para 4-21) Close the control panel (para 4-19)</p> <p>e. Install access panel (para 4-15)</p>	

4-11. MANDATORY REPLACEMENT PARTS.

The table below lists all items that must be replaced during PMCS whether they have failed or not The table reflects the interval at which these items must be replaced whether hardtime maintenance or on condition maintenance is the determining factor.

NOTE

The following part numbers can be found in Appendix G of this manual.

Table 4-2. Monthly Mandatory Replacement Parts

<u>Item No</u>	<u>Part Number</u>	<u>Nomenclature</u>	<u>Qty</u>
1	500K1950-3	Washer, Lock	6

Table 4-3. Semi-Annually Mandatory Replacement Parts

<u>Item No</u>	<u>Part Number</u>	<u>Nomenclature</u>	<u>Qty</u>
1	500K1950-3	Washer, Lock	10

Table 4-4. Annual Mandatory Replacement Parts

<u>Item No</u>	<u>Part Number</u>	<u>Nomenclature</u>	<u>Qty</u>
1	500K1950-3	Washer, Lock	10

SECTION IV UNIT TROUBLESHOOTING INSTRUCTIONS

4-12. TROUBLESHOOTING.

The following procedures are listed in order of the most probable malfunctions. Each malfunction is followed by test or inspection procedures in logical order to isolate and identify the fault and actions required to correct it. This section cannot list all the possible malfunctions that may occur with the equipment. If a malfunction occurs that is not listed or actions listed do not correct a malfunction, notify your supervisor.

a. Refrigeration Unit Does Not Start.

TEST FUSES (PARA 4-24) AND REPLACE IF NEEDED.
 DOES REFRIGERATION UNIT START?

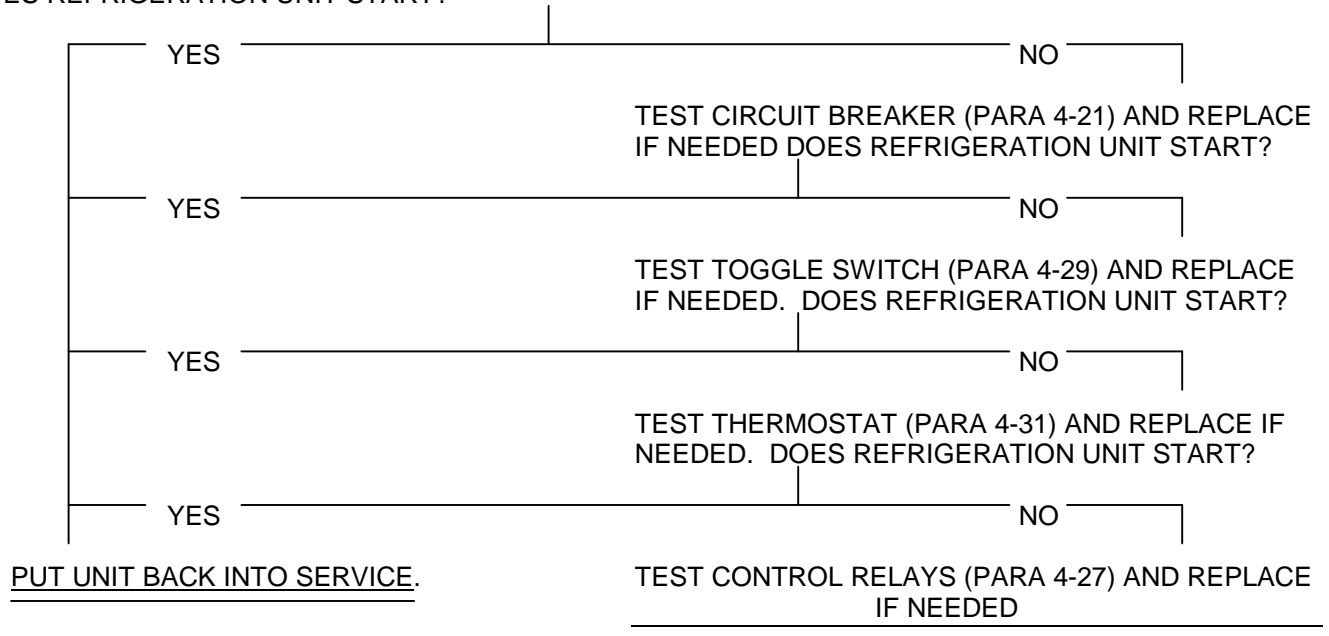

b. Circuit Breaker Trips.

TEST AC MOTOR (PARA 4-41) AND REPLACE IF NEEDED DOES REFRIGERATION UNIT START?

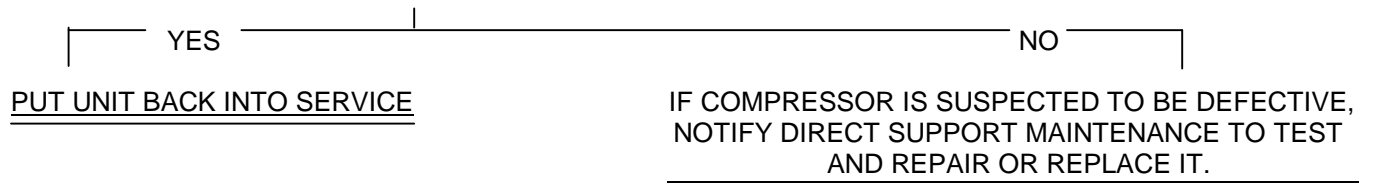

c. Reset Button Trips.

TEST MOTOR STARTER (PARA 4-25) AND REPLACE STARTER OR THERMAL OVERLOAD HEATER IF NEEDED. DOES REFRIGERATION UNIT START?

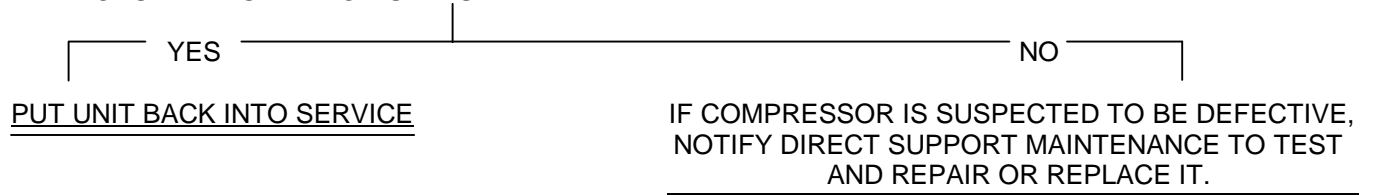

4-12. TROUBLESHOOTING. - Continued

d. Thermometer Indicates More Than 15° F (7° C) Above or Below Remote Bulb Thermostat Setting.

TEST THERMOSTAT (PARA 4-31) AND REPLACE IF NEEDED OPERATE UNIT (PARA 2-5). DOES REFRIGERATOR TEMPERATURE INDICATE WITHIN 15° F (7° C) OF TEMPERATURE CONTROL?

YES _____ NO _____

TEST REPEAT CYCLE TIMER (PARA 4-30) AND REPLACE IF NEEDED OPERATE UNIT (PARA 2-5). DOES REFRIGERATOR TEMPERATURE INDICATE WITHIN 15° F (7° C) OF TEMPERATURE CONTROL?

YES _____ NO _____

REPLACE DEFROST TERMINATION THERMOSTAT (PARA 4-51) OPERATE UNIT (PARA 2-5). DOES REFRIGERATOR TEMPERATURE INDICATE WITHIN 15° F (7° C) OF TEMPERATURE CONTROL?

YES _____ NO _____

PUT UNIT BACK INTO SERVICE

CHECK SETTING AND ADJUST REPEAT CYCLE TIMER (PARA 4-30) IF NEEDED

e. Pressure Gage (Discharge Pressure) Indicates Above 270 psi (1863 kPa).

OPEN ALL REFRIGERATION VALVES (PARA 4-7) IF ANY VALVES WERE CLOSED, OPERATE UNIT (PARA 2-5). IS DISCHARGE PRESSURE BELOW 270 PSI (1863 kPa)?

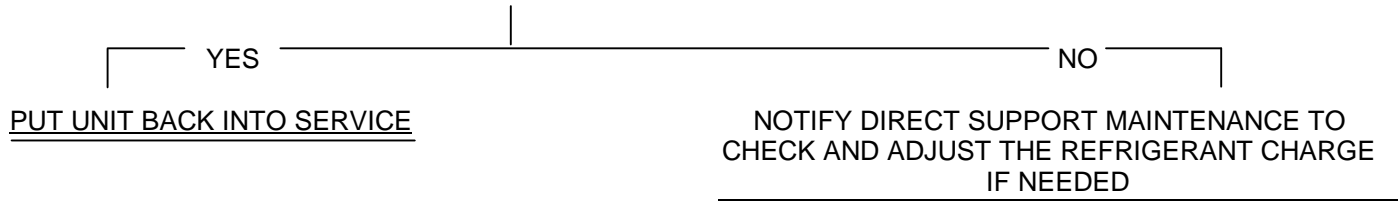

f. Pressure Gage (Discharge Pressure) Indicates Below 160 psi (1104 kPa).

OPEN ALL REFRIGERATION VALVES (PARA 4-7) IF ANY VALVES WERE CLOSED, OPERATE UNIT (PARA 2-5) IS DISCHARGE PRESSURE ABOVE 160 PSI (1104 kPa)?

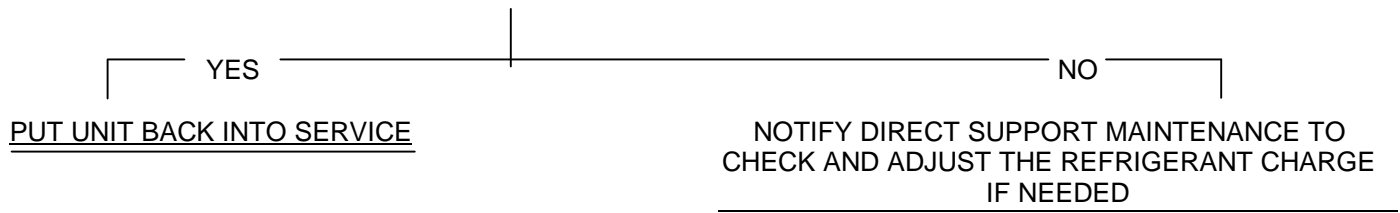

g. Pressure Gage (Suction) Indicates Above 15 psi (104 kPa).

OPEN ALL REFRIGERATION VALVES (PARA 4-7) IF ANY VALVES WERE CLOSED, OPERATE UNIT (PARA 2-5). IS SUCTION PRESSURE BELOW 15 PSI (104 kPa)?

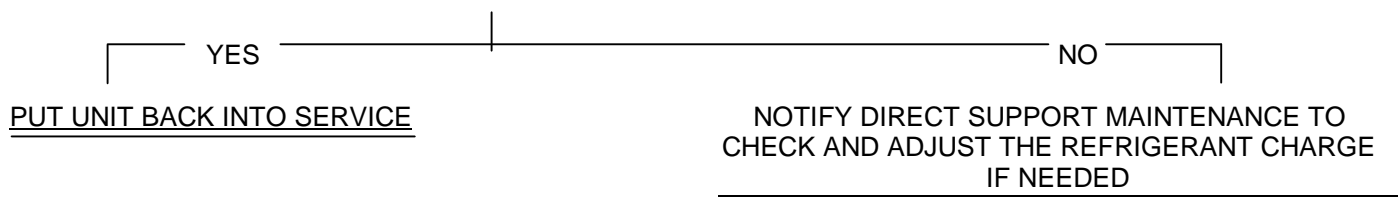

4-12. TROUBLESHOOTING. - Continued

h. Pressure Gage (Suction) Indicates Below 0 psi (0 kPa).

OPEN ALL REFRIGERATION VALVES (PARA 4-7). IF ANY VALVES WERE CLOSED, OPERATE UNIT (PARA 2-5). IS SUCTION PRESSURE ABOVE 0 PSI (0 kPa)?

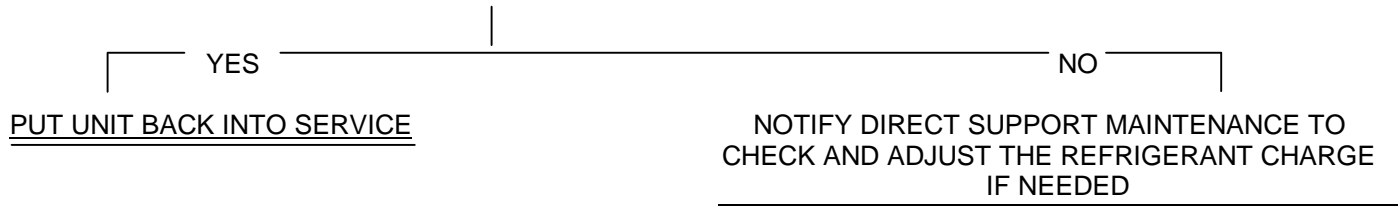

i. Compressor Operates For Short Period Then Stops.

OPERATE REFRIGERATION UNIT (PARA 2-5) AND OBSERVE PRESSURE GAGES. ARE PRESSURES WITHIN NORMAL OPERATING RANGE?



SECTION V UNIT MAINTENANCE PROCEDURES

4-13. BARREL BOLTS REPLACEMENT.

This task covers. a. Removal b. Installation

INITIAL SETUP

Equipment Conditions:

Refrigeration unit shut down (para 2-7) and power disconnected.

General Safety Instructions:

WARNING

High voltage and exposed rotating parts are used in the refrigerant on unit. Personal injury can result if power is connected.

Materials/Parts:

Lock Washers (6) (Each Barrel Bolt Assembly)
1, Appendix G

a. Removal.

- (1) Remove four bolts (1), lock washers (2), barrel bolt (3) Discard lock washers.
- (2) Remove two bolts (4), lock washers (5), and barrel bolt clip (6). Discard lock washers.

b. Installation.

- (1) Install barrel bolt clip (6), two new lock washers (5), and bolts (4).
- (2) Install barrel bolt (3), four new lock washers (2), and bolts (1).

4-13. BARREL BOLTS REPLACEMENT. - Continued

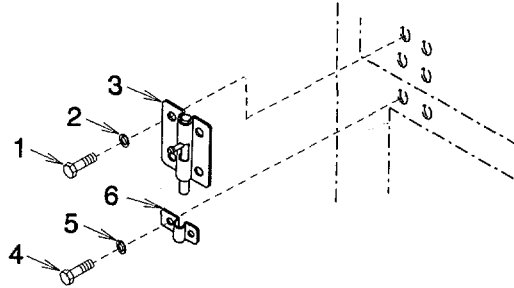

Figure 4-8. Barrel Bolts

NOTE

FOLLOW-ON MAINTENANCE:
Connect power and put unit back into service.

4-14. TOP ACCESS PANEL REPLACEMENT.

This task covers. a. Removal b. Installation

INITIAL SETUP

Equipment Conditions:

Refrigeration unit shut down (para 2-7) and power disconnected.

General Safety Instructions:

WARNING

High voltage and exposed rotating parts are used in the refrigerant on unit. Personal injury can result if power is connected.

Materials/Parts:

Lock Washers (6) (Each Barrel Bolt Assembly)
1, Appendix G

- a. Removal Remove six bolts (1), lock washers (2), and panel (3). Discard lock washers.
- b. Installation. Install panel (3), six new lock washers (2), and bolts (1).

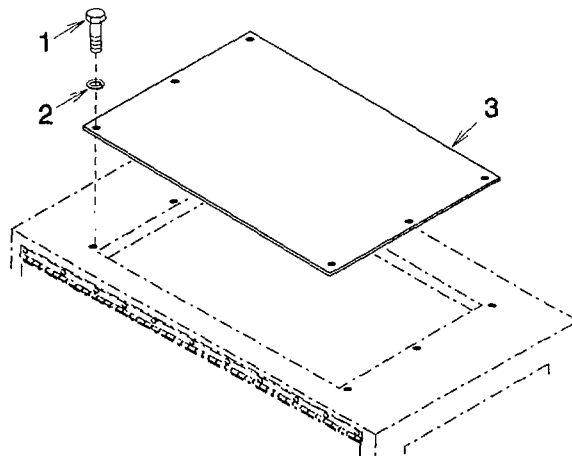

**Figure 4-9. Top Panel
NOTE**

FOLLOW-ON MAINTENANCE
Connect power and put unit back into service.

4-15. ACCESS PANEL REPLACEMENT.

This task covers. a. Removal b. Installation

INITIAL SETUP

Equipment Conditions:

Refrigeration unit shut down (para 2-7) and power disconnected.

General Safety Instructions:

WARNING

High voltage and exposed rotating parts are used in the refrigerant on unit. Personal injury can result if power is connected.

- a. Removal. Remove eight screws (1), and panel (2).
- b. Installation. Install panel (2), and eight screws (1).

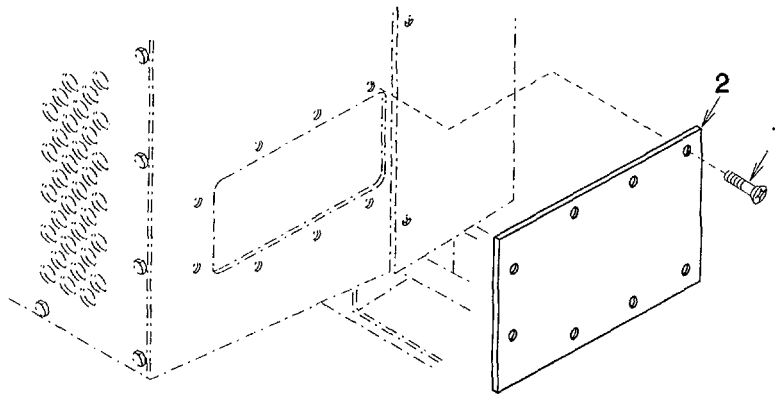

Figure 4-10. Access Panel

NOTE

FOLLOW-ON MAINTENANCE
Connect power and put unit back into service.

4-16. COVER PANEL (COIL GUARD REAR) REPLACEMENT.

This task covers. a. Removal b. Installation

INITIAL SETUP

Equipment Conditions:

Refrigeration unit shut down (para 2-7) and power disconnected.

General Safety Instructions:

WARNING

High voltage and exposed rotating parts are used in the refrigerant on unit. Personal injury can result if power is connected.

- a. Removal. Remove thirty four bolts (1), flat washers (2) and cover panel (3).
- b. Installation Install cover panel (3), thirty four bolts (1), and flat washers (2).

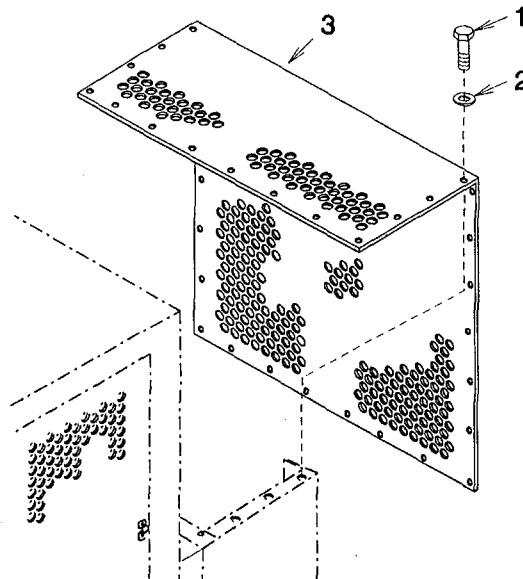

Figure 4-11. Cover Panel (Coil Guard Rear)

NOTE

FOLLOW-ON MAINTENANCE:
Connect power and put unit back into service.

4-17. COIL GUARD FRONT PANEL REPLACEMENT.

This task covers. a. Removal b. Installation

INITIAL SETUP

Equipment Conditions:

Refrigeration unit shut down (para 2-7) and power disconnected.

Materials/Parts:

Lock Washers (6)
1, Appendix G

General Safety Instructions:

WARNING

High voltage and exposed rotating parts are used in the refrigerant on unit. Personal injury can result if power is connected.

- a. Removal. Remove six bolts (1), lock washers (2) and coil guard front panel (3). Discard lock washers.
- b. Installation. Install coil guard front panel (3), six bolts (1), and new lock washers (2).

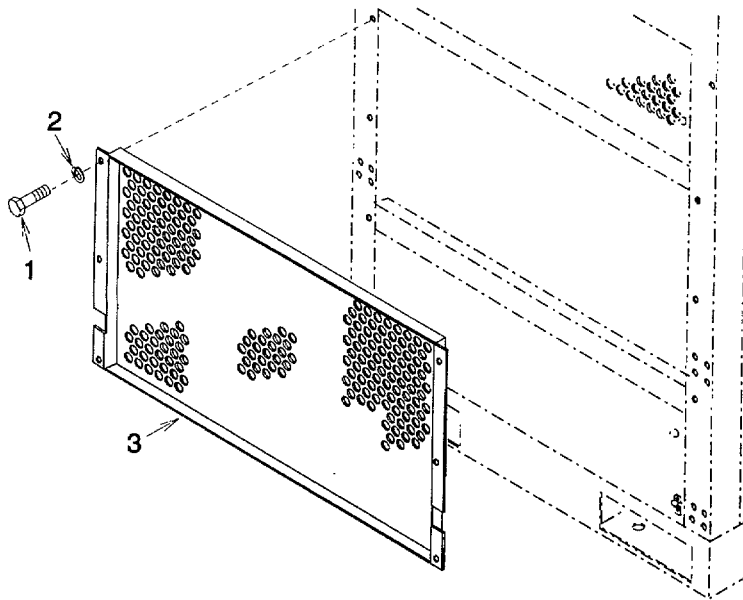

Figure 4-12. Coil Guard Front Panel

NOTE

FOLLOW-ON MAINTENANCE
Connect power and put unit back into service.

4-18. UNIT MOUNTING BOLT ASSEMBLY REPLACEMENT.

This task covers. a. Removal b. Installation

INITIAL SETUPEquipment Conditions:

Refrigeration unit shut down (para 2-7) and power disconnected.

Materials/Parts:

Self locking Nut (4)
9, Appendix G
Chain
Figure F-6, Appendix F

General Safety Instructions:

WARNING

High voltage and exposed rotating parts are used in the refrigerant on unit. Personal injury can result if power is connected.

NOTE

- Chain, swivel and rivet are an assembly and do not have to be disassembled unless it is for replacement.
- The following procedures are typical for all four unit mounting bolt assemblies.

a. Removal. Remove screw (1) and unit mounting bolt (2)

b. Disassembly.

(1) Remove self locking nut (3), swivel (4), flat washer (5) and screw (2). Discard self locking nut

(2) Drill through rivet (6) using drill bit slightly smaller than rivet diameter. Remove any remaining rivet material, swivel (4) and chain (7).

c. Assembly.

(1) Install rivet (6), swivel (4) and chain (7).

(2) Assemble unit mounting bolt assembly (2), new self locking nut (3), swivel (4), and flat washer (5).

d. Installation.

(1) Install unit mounting bolt (2) and screw (1).

4-18. UNIT MOUNTING BOLT ASSEMBLY REPLACEMENT. - Continued

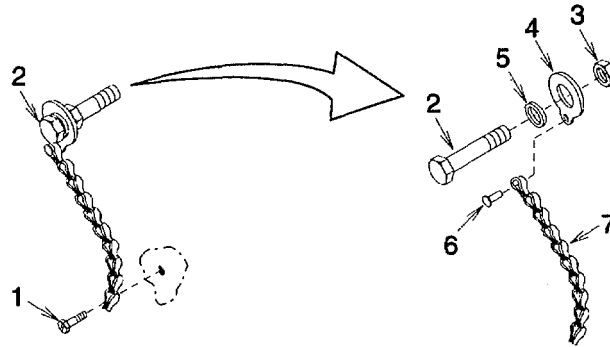

Figure 4-13. Unit Mounting Bolt Assembly

NOTE

FOLLOW-ON MAINTENANCE:
Connect power and put unit back into service.

4-19. CONTROL BOX ASSEMBLY REPLACEMENT.

This task covers a. Removal b Installation

INITIAL SETUP

Materials/Parts:

Lock Washers (7)
1, Appendix G
Self Locking Nut
12, Appendix G
Tiedown strap(s) (as required)
24, Appendix E
Silicone RTV
20, Appendix E

Equipment Conditions:

Refrigeration unit shut down (para 2-7) and power disconnected.
Control box cover door raised and latched.
Cover panel removed (para 4-16).

General Safety Instructions:

WARNING

High voltage is used in the refrigeration unit.
Personal injury can result if power is connected.

a. Removal.

- (1) Be sure power has been disconnected at the source and remove two bolts (1) and lock washers (2). Open control panel (3). Discard lock washers.
- (2) Remove two bolts (4) and lock washers (5). Discard lock washers.
- (3) Carefully pull circuit breaker cover (6) out.
- (4) Remove two bolts (7), lock washers (8), flat washers (9), and sensing bulb bracket (10). Discard lock washers.
- (5) Remove self locking nut (11), lock washer (12), and bolt (13) Discard self locking nut.
- (6) Remove clamp (14) but not clamp (15).
- (7) Remove tiedown straps (16) and grommets (17) as necessary to remove sensing bulb (18). Carefully pull sensing bulb through access sleeve (19) in heat shield frame.
- (8) Remove any silicone RTV remaining in grommets (17).
- (9) Tag and disconnect wire leads from components as necessary then pull leads from control box assembly.
- (10) Remove six screws (20) and control box assembly (21).

4-19. CONTROL BOX ASSEMBLY REPLACEMENT, -Continued

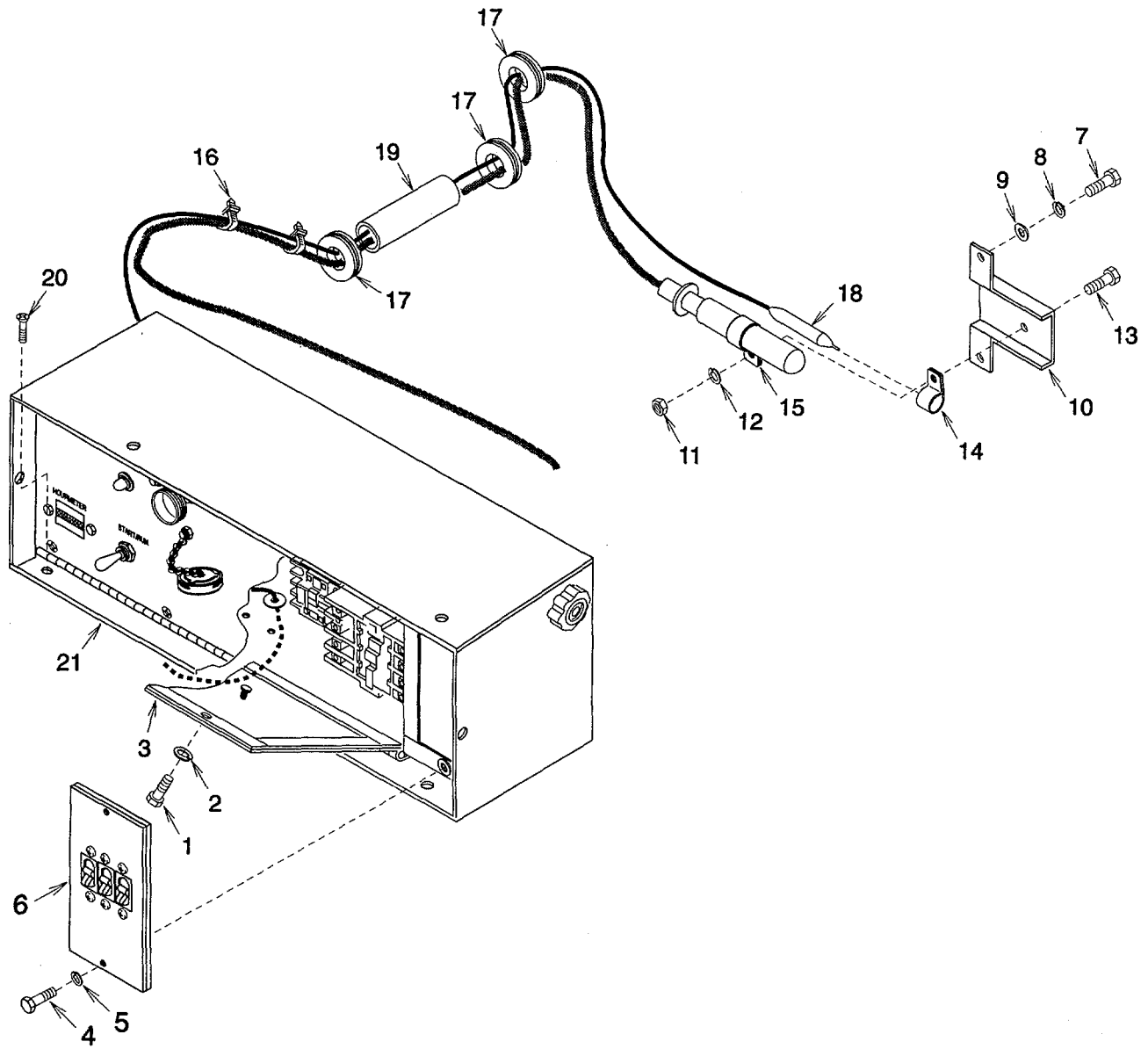

Figure 4-14. Control Box Assembly

b. Installation.

- (1) Install control box assembly (21) and secure with six screws (20).
- (2) Using tags and wiring diagram (fig 1-4), connect all wire leads to appropriate components. Remove tags.
- (3) Carefully push sensing bulb (18) through grommets (17), and access sleeve (19).

- (4) Install grommets (17) and tie down straps (16) as necessary.
- (5) Slip clamp (14) over sensing bulb (18).
- (6) Install clamps (14) and (15), bolt (13), new lock washer (12) and new self locking nut (11).
- (7) Install sensing bulb bracket (10), flat washers (9), new lock washers (8), and two bolts (7).
- (8) Install circuit breaker cover (6) and secure with new lock washers (5) and two screws (4).
- (9) Close control panel (3) and install two new lock washers (2) and bolts (1).
- (10) Apply silicone RTV into grommets (17) to seal evaporator enclosure.

NOTE

FOLLOW-ON MAINTENANCE:
Unlatch and close control box cover door.
Install cover panel (para 4-16)
Connect power and put unit back into service.

4-20. WIRES, CABLES, AND HARNESSES TESTING, REPAIR, AND REPLACEMENT.

This task covers a. Testing b. Repair c. Removal d. Installation

INITIAL SETUP

Tools:

Heat Gun
3, Section III, Appendix B

Materials/Parts:

Wire (As Required)
Insulation Sleeving (As Required)
Figure F-3, Appendix F
Lock Washers (2)
1, Appendix G
Solder
8, Appendix E
Flux
9, Appendix E
Marker Tag(s) (As Required)
7, Appendix E
Tiedown Strap(s) (As Required)
24, Appendix E
Silicone RTV
20, Appendix E

Equipment Conditions:

Refrigeration unit shut down (para 2-7) and power disconnected.
Side doors open.
Control box cover door raised and latched.
Enclosure assembly open.
Access panel removed (para 4-15).

General Safety Instructions:

WARNING

High voltage and exposed rotating parts are used in the refrigeration unit. Personal injury can result if power is connected.

a. Testing.

- (1) Be sure power has been disconnected at the source and remove two bolts (1) and lock washers (2). Open control panel (3) Discard lock washers.
- (2) Tag and disconnect wire leads from components as necessary to isolate the wire or harness being tested.
- (3) Using multimeter set to measure continuity, check each end of the wire lead(s).
- (4) Replace any wire lead(s) that do not show continuity.
- (5) Connect wire lead(s) per tag and wiring diagram (fig 1-4).

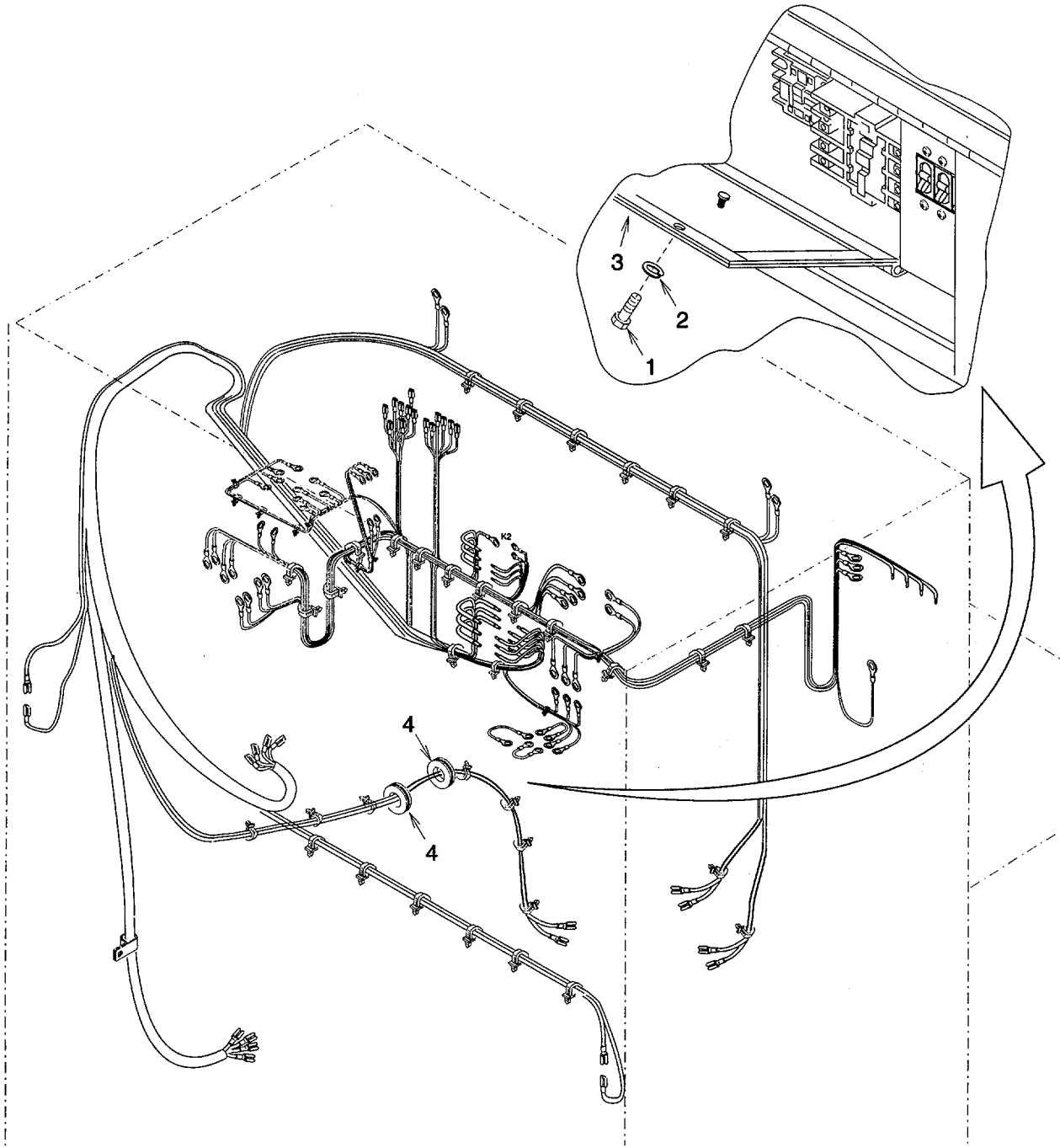

Figure 4-15. Wires Cables and Harnesses

4-20. WIRES, CABLES, AND HARNESSES TESTING, REPAIR, AND REPLACEMENT. -Continued

- b. Repair Repairs can be performed to replace terminal ends or to splice wire when cut.

WARNING

Solder and flux contain materials which are hazardous to health. Avoid breathing vapors or fumes from soldering operations. Perform operations only in well ventilated areas. Wash hands with soap and water after handling solder and flux. Wear thermal gloves and protective goggles or face shield to protect against burns.

- (1) Soldering Connections. Wire connections must be made mechanically sound before they are soldered, solder alone does not provide sufficient strength to prevent breakage. Joining surfaces of connections to be soldered must be clean and bright. Flux should be brushed onto the joint before soldering. Wires should always be heated to the point at which the solder will melt completely and flow into all parts of the joint. Excessive build up of solder "gobs" on the joint should be avoided or removed.
- (2) Insulating Joints. The preferred method of insulating electrical joints is by the use of heat-shrink tubing. To apply, cut a piece of heat-shrink tubing of suitable diameter to a length of 1 inch (2.5 cm) for covering joints at terminals or connectors, or to a length about 1/2 inch (1.3 cm) longer than the joint to be insulated. Slide the tubing over the wire before making the joint. After the joint is made, slide the tubing so that it covers the joint and shrink in place with moderate heat.
- (3) Splicing Wire. To repair broken or cut wires that are otherwise sound, the mating ends can be stripped and spliced. Solder and apply insulation as described above.
- (4) Crimping Terminals. To install a terminal on the end of a wire, strip 1/4-1/2 inch (0.6-1.3 cm) of insulation from the end of the wire and apply a one inch (2.4 cm) piece of heat shrink tubing (if the terminals are of the uninsulated type). Insert wire-end into the shank of the terminal. Crimp the shank and install heat-shrink tubing, if necessary.

NOTE

Preferred repair methods consist of replacing wires, terminals, connectors, etc, rather than splicing wires, bending ends to form terminals, and other make shift procedures, although the latter may be appropriate for emergency field repairs.

- (5) Determine the proper size and length of the wire, or terminal, or connector to be used for replacement by referring to the wire list (table 4-3), and to the wiring diagram (fig 1-4).

c. Removal.

- (1) Tag and disconnect wire lead(s) from component.
- (2) Remove tiedown straps and loosen clamp(s) as necessary to remove wire(s).
- (3) Remove any silicone RTV remaining in grommets (4).

Table 4-3. Wire List

TERMINATION		TERMINATION		AWG WIRE SIZE	LENGTH	
FROM	TERMINAL TYPE	TO	TERMINAL TYPE		IN.	CM
CB1-A2	MS25036-112	K1-L1		12 AWG-WHT	24.00	60.96
CB1-B2	MS25036-112	K1-L2		12 AWG-WHT	24.00	60.96
CB1-C2	MS25036-112	K1-L3		12 AWG-WHT	24.00	60.96
K1-L1		K2-L1		14 AWG-WHT	12.00	30.48
K1-L2		K2-L2		14 AWG-WHT	12.00	30.48
K1-L3		K2-L3		14 AWG-WHT	12.00	30.48
K1-L2		F1-1	MS25036-153	14 AWG-WHT	12.00	30.48
K1-L3		F2-1	MS25036-153	14 AWG-WHT	12.00	30.48
OL1-T1		B1-1	12712937-1 (19200)	SEE NOTE 1	72.00	182.88
			12712936 (19200)	BLK		
OL2-T2		B1-2	12712937-1 (19200)	SEE NOTE 1	72.00	182.88
			12712936 (19200)	WHT		
OL3-T3		B1-3	12712937-1 (19200)	SEE NOTE 1	72.00	182.88
			2712936 (19200)	RED		
GND	MS25036-112	B1-GND	MS25036-112	SEE NOTE 1	72.00	182.88
				GRN		
K1-A1		M1-1	MS25036-103	18 AWG-WHT	30.00	76.20
K1-A2		K2-A2		18 AWG-WHT	12.00	30.48
K1-A2		F2-2	MS25036-102	18 AWG-WHT	12.00	30.48
K1-96		S5-M	MS25036-102	18 AWG-WHT	106.00	269.24
K1-95		S5-2	MS25036-102	18 AWG-WHT	104.00	264.16
K2-T1		B2-1	12712937-1 (19200)	SEE NOTE 2	72.00	182.88
			12712936 (19200)	BLK		
K2-T2		B2-3	12712937-1 (19200)	SEE NOTE 2	72.00	182.88
			12712936 (19200)	RED		
K2-T3		B2-2	2712937-1 (19200)	SEE NOTE 2	72.00	182.88
			12712936 (19200)	WHT		
GND	MS25036-108	B2-GND	MS25036-108	SEE NOTE 2	72.00	82.88
				GRN		
K2-A1		TM1-1	MS25036-102	18 AWG-WHT	24.00	60.96
K2-A2		K3-B	13216E6191-1 (97403)	18 AWG-WHT	12.00	30.48
S7-NO	(D) 82898 (16004)	S1-2	MS25036-102	18 AWG-WHT	120.00	304.80

Table 4-3. Wire List

TERMINATION		TERMINATION		AWG WIRE SIZE	LENGTH	
FROM	TERMINAL TYPE	TO	TERMINAL TYPE		IN.	CM
S1-2	MS25036-102	K3-7	13216E6191-1 (97403)	18 AWG-WHT	24 00	60 96
K3-7	13216E6191-1 (97403)	K4-7	13216E6191-1 (97403)	18 AWG-WHT	12.00	3048
F2-2	MS25036-149	L1-B	12712937-2 (19200)	18 AWG-WHT	120.00	304 80
			12712936 (19200)			
OL3-T3		S5-V	MS25036-102	18 AWG-WHT	108 00	274 32
F2-2	MS25036-149	L2-B	12712937-2 (19200)	18 AWG-WHT	120 00	304 80
				12712936 (19200)		
K3-4		S2-LINE	MS25036-102	18 AWG-WHT	106 00	269.24
K3-4		K4-4	MS25036-102	18 AWG-WHT	12 00	30 48
K3-A	13216E6191-1(97403)	S3-2	MS25036-102	18 AWG-WHT	24 00	60 96
K3-B	13216E6191-1(97403)	K4-B	13216E6191-1 (97403)	18 AWG-WHT	12.00	30.48
K4-7	13216E6191-1(97403)	K4-9	13216E6191-1 (97403)	18 AWG-WHT	300	7.62
K4-A	13216E6191-1(97403)	MI-1	MS25036-103	18 AWG-WHT	24 00	60.96
K4-6	13216E6191-1(97403)	TM1-7	MS25036-102	18 AWG-WHT	12 00	30 48
K4-B	13216E6191-1(97403)	TM1-B	MS25036-102	18 AWG-WHT	12 00	30 48
TM1-4	MS25036-102	DS1-1	MS25036-102	18 AWG-WHT	24.00	60 96
TM1-4	MS25036-102	L2-A	12712937-2 (19200)	18 AWG-WHT	120 00	304 80
			12712936 (19200)			
TM1-A	MS25036-102	S4-2	12712937-2 (19200)	18 AWG-WHT	113.00	287 02
			12712936 (19200)			
TM1-6	MS25036-102	S3-2	MS25036-102	18 AWG-WHT	12 00	30 48
TM1-9	MS25036-102	S1-3	MS25036-102	18 AWG-WHT	12 00	30.48
TM1-B	MS25036-102	M1-2	MS25036-103	18 AWG-WHT	12.00	30 48
S3-1	MS25036-102	S4-1	12712937-2 (19200)	18 AWG-WHT	100 00	254 00
			12712936 (19200)			
S3-1	MS25036-102	S1-3	MS25036-102	18 AWG-WHT	12 00	30.48
S3-2	MS25036-102	L1-A	12712937-2 (19200)	18 AWG-WHT	120 00	304.80
12712936						
S2-M1	MS25036-102	S5-L	MS25036-102	18 AWG-WHT	20 00	50 80
TB1-2	MS25036-112	GND	MS25036-112	12 AWG-WHT	12.00	30.48
F1-2	MS25036-149	S6-C	(D) 82898 (16004)	18 AWG-WHT	100.00	254.00

Table 4-3. Wire List-Continued

TERMINATION		TERMINATION		AWG WIRE SIZE	LENGTH	
FROM	TERMINAL TYPE	TO	TERMINAL TYPE		IN.	CM
S6-NO	(D) 82898 (16004)	S7-C	(D) 82898 (16004)	18 AWG-WHT	96.00	243.84
TB2-A		CB1-A1	MS25036-112	12 AWG-WHT	36.00	91.44
TB2-B		CB1-B1	MS25036-112	12 AWG-WHT	36.00	91.44
TB2-C		CB1-C1	MS25036-112	12 AWG-WHT	36.00	91.44
TB2-N		TBI-1	MS25036-112	12 AWG-WHT	36.00	91.44
GND	MS25036-102	TB1-2	MS25036-112	12 AWG-WHT	36.00	91.44
GND	MS25036-102	FR GND	MS25036-157	12 AWG-WHT	24.00	60.96
Control Panel	MS20659-143 (96906)	TB1 (Unit GND)	MS20659-130 (96906)	SEE NOTE 3	4.00	10.06
AC Motor	MS20659-143 (96906)	FRAME	MS20659-130 (96906)	SEE NOTE 3	16.00	40.64
Compressor	MS20659-130 (96906)	FRAME	MS20659-130 (96906)	SEE NOTE 4	9.00	22.86

NOTE

- 1 Type SO Cable, Conductor Size 12-4, 20 Amps Minimum Rating 250 Vac.
- 2 Type SO Cable, Conductor Size 14-4, 15 Amps Minimum Rating 250 Vac.
- 3 Tubular braided wire QQ-B-575/R30T281.
- 4 Tubular braided wire QQ-B-575/R30T375.

d. Installation.

- (1) Carefully route wire lead(s) through clamp(s) and grommet(s) as necessary.
- (2) Connect wire lead(s) to component using tags and wiring diagram (fig 1-4). Remove tags
- (3) Install tiedown straps as necessary and tighten any clamp(s) that were loosened for removal.
- (4) Apply silicone RTV into evaporator frame grommets (4) to seal evaporator enclosure.
- (5) Close control panel (3). Install two new lock washers (2) and bolts (1).

NOTE

FOLLOW-ON MAINTENANCE:
 Install access panel (para 4-15).
 Close side doors.
 Close enclosure assembly.
 Unlatch and close control box cover door.
 Connect power and put unit back into service.

4-21. CIRCUIT BREAKER CB1 TESTING AND REPLACEMENT.

This task covers. a. Testing b. Removal c. Installation

INITIAL SETUP

Equipment Conditions:

Refrigeration unit shut down (para 2-7) and power disconnected.
Control box cover door raised and latched.

General Safety Instructions:

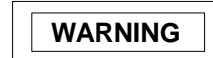

High voltage and exposed rotating parts are used in the refrigeration unit. Personal injury can result if power is connected.

Materials/Parts:

- Lock Washers (2)
1, Appendix G
 - Lock Washers (6)
6, Appendix G
 - Marker Tags (6)
7, Appendix E
-

a. Testing. (See Figure 1-4)

- (1) Be sure power has been disconnected at the source and remove two bolts (1) and lock washers (2). Discard lock washers.
- (2) Carefully pull circuit breaker cover (3) out to expose circuit breaker (4) terminals.
- (3) Using multimeter set to measure continuity, check circuit breaker (4) continuity between terminals A1 to A2, B1 to B2, and C1 to C2 with circuit breaker in both ON and OFF position. Continuity should be indicated only when circuit breaker (4) is in the ON position. If continuity was indicated in the OFF position or if no continuity was indicated in the ON position, Replace circuit breaker (4)
- (4) If no failure was indicated, carefully push circuit breaker cover (3) into place and install two new lock washers (2) and bolts (1).

b. Removal.

- (1) Be sure power has been disconnected at the source and remove two bolts (1) and lock washers (2). Discard lock washers.
- (2) Remove six screws (5), lock washers (6), and circuit breaker cover (3). Discard lock washers.
- (3) Check gasket (7) material for damage. If damaged, notify direct support maintenance to replace it.

NOTE

Terminal hardware is supplied with circuit breaker.

- (4) Tag wire lead terminals (8) and remove six nuts (9), lock washers (10), and wire lead terminals.

c. Installation.

- (1) Using tags and wiring diagram (fig 1-4), install wire lead terminals (8), six lock washers (10), and nuts (9). Remove tags.
- (2) Install circuit breaker cover (3), six new lock washers (6), and screws (5).
- (3) Carefully push circuit breaker cover (3) into place and install two new lock washers (2) and bolts (1).

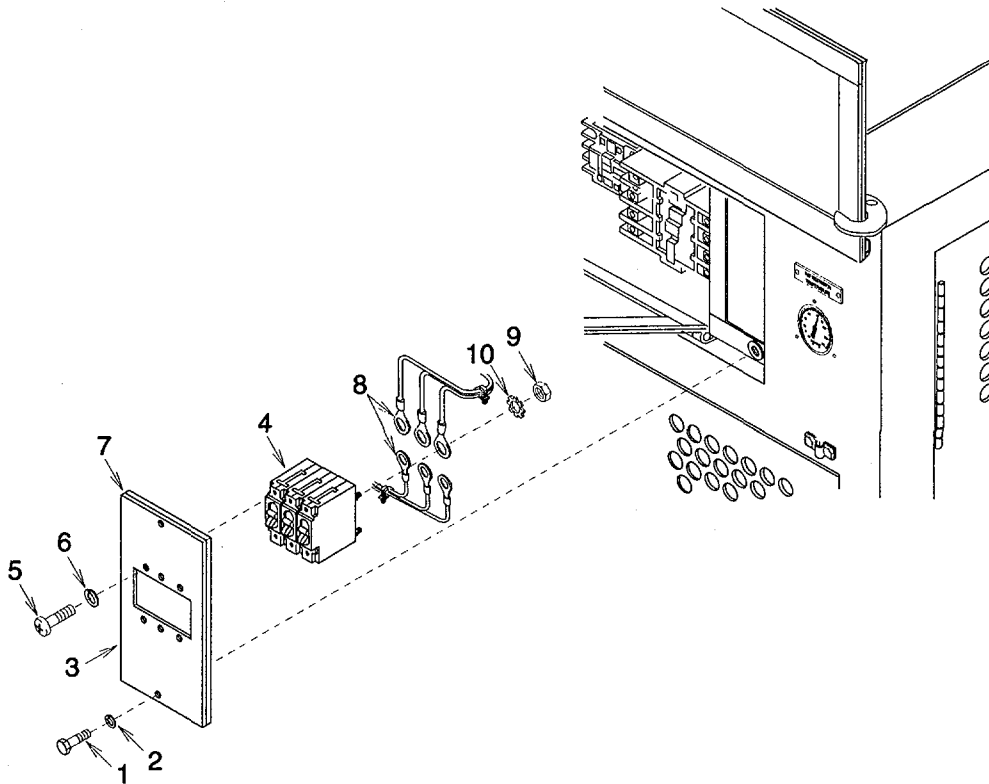

Figure 4-16. Circuit Breaker

NOTE

FOLLOW-ON MAINTENANCE:
 Unlatch and close control box cover door.
 Connect power and put unit back into service.

4-22. RESISTOR R1 ASSEMBLY TESTING AND REPLACEMENT

This task covers a. Testing b. Removal c. Assembly d. Installation

INITIAL SETUP

Equipment Conditions:

Refrigeration unit shut down (para 2-7) and power disconnected.
Control box cover door raised and latched.

Materials/Parts:

Lock Washers (2)
1, Appendix G
Marker Tags (4)
7, Appendix E
Sleeving Insulation (2)
4, Figure F-3, Appendix F

General Safety Instructions:



WARNING

High voltage and exposed rotating parts are used in the refrigeration unit. Personal injury can result if power is connected.

a. Testing. (See Figure 1-4)

- (1) Be sure power has been disconnected at the source and remove two bolts (1) and lock washers (2). Open control panel (3). Discard lock washers.
- (2) Remove cap (4) and lamp (5).
- (3) Using multimeter set to measure resistance, check resistance between resistor assembly (6) leads. Indicated resistance should be between 4 75 k ohms and 5 25 k ohms. If indicated resistance was outside specified range replace resistor assembly.
- (4) If no failure was indicated, install lamp (5) and cap (4).
- (5) Close control panel (3). Install two new lock washers (2) and bolts (1).

b. Removal.

- (1) Be sure power has been disconnected at the source and remove two bolts (1) and lock washers (2). Open control box panel (3). Discard lock washers.

NOTE

Terminal hardware is supplied with indicator base and hourmeter.

- (2) Tag wire leads and remove screw (7), lock washer (8), screw (9), and resistor assembly (6).

c. Assembly.

- (1) Install sleeving insulation (10) on resistor (11) wire leads
- (2) Crimp terminal lugs (12) on wire leads

d. Installation.

- (1) Using tags and wiring diagram (fig. 1-4), install resistor assembly (6), screw (9), lock washer (8) and screw (7). Remove tags.
- (2) Close control panel (3). Install two new lock washers (2) and bolts (1).

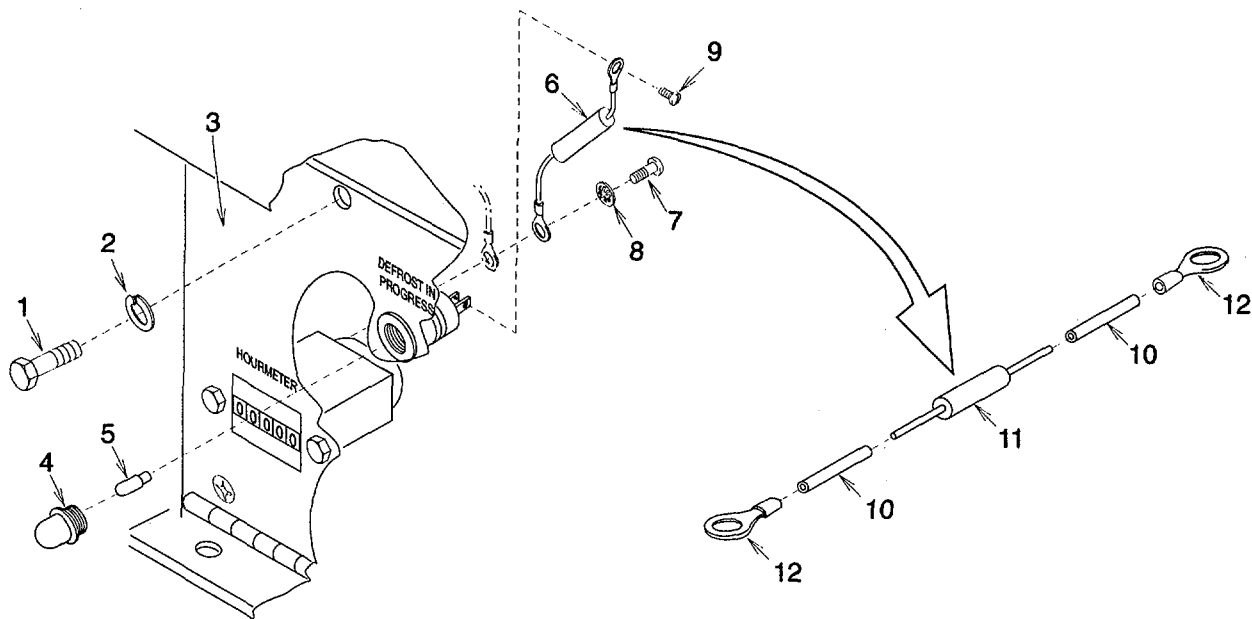

Figure 4-17. Resistor R1 Assembly

NOTE

FOLLOW-ON MAINTENANCE:
 Unlatch and close control box cover door.
 Connect power and put unit back into service.

4-23. LAMP DS1 ASSEMBLY TESTING AND REPLACEMENT.

This task covers a. Testing b. Removal c. Assembly d. Installation

INITIAL SETUP

Equipment Conditions:

Refrigeration unit shut down (para 2-7) and power disconnected.
Control box cover door raised and latched.

Materials/Parts:

Lock Washers (2)
1, Appendix G
Marker Tags (2)
7, Appendix E

General Safety Instructions:

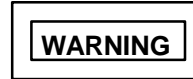

High voltage and exposed rotating parts are used in the refrigeration unit. Personal injury can result if power is connected.

a. Testing. (See Figure 1-4)

- (1) Be sure power has been disconnected at the source and remove indicator cap (1) and lamp (2).
- (2) Using multimeter set to measure continuity, check lamp (2) continuity between terminals. Continuity should be indicated. If no continuity was indicated, replace lamp (2).
- (3) If no failure was indicated, install lamp (2), and indicator cap (1).

b. Removal.

- (1) Be sure power has been disconnected at the source and remove indicator cap (1) and lamp (2).
- (2) Remove two bolts (3) and lock washers (4). Open control panel (6). Discard lock washers.
- (3) Tag wire lead terminals (6) and remove two screws (7) and wire lead terminals.

NOTE

Terminal and base mounting hardware is supplied with indicator base.

- (4) Remove nut (8), lock washer (9), and indicator base (10).

c. Installation.

- (1) Install indicator base (10), lock washer (9), and nut (8).
- (2) Using tags and wiring diagram (fig 1-4), install wire lead terminals (6) and two screws (7). Remove tags.

- (3) Close control panel (5) . Install two new lock washers (4) and bolts (3).
- (4) Install lamp (2) and indicator cap (1).

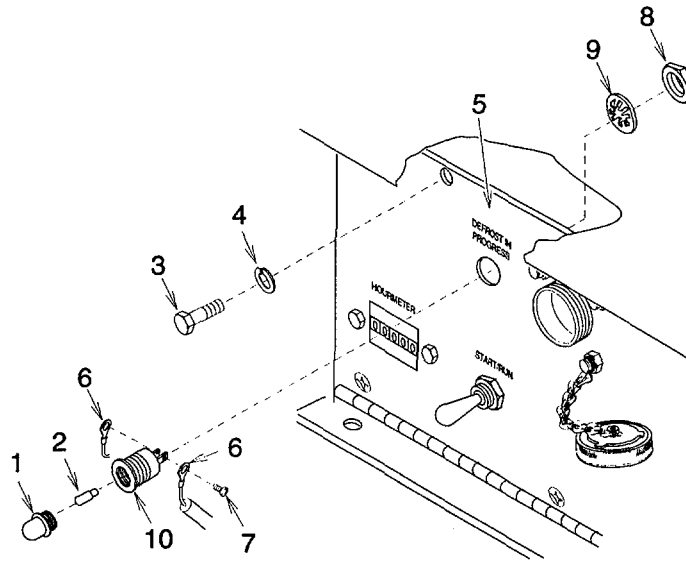

Figure 4-18. Lamp DS1 Assembly

NOTE

FOLLOW-ON MAINTENANCE:
 Unlatch and close control box cover door.
 Connect power and put unit back into service.

4-24. FUSES F1 AND F2 TESTING AND REPLACEMENT.

This task covers a. Testing b. Removal c. Installation

INITIAL SETUP

Materials/Parts:

- Lock Washers (2)
1, Appendix G
- Marker Tags (4)
- Marker Tags (4)

Equipment Conditions:

- Refrigeration unit shut down (para 2-7) and power disconnected.
- Control box cover door raised and latched.

General Safety Instructions:



High voltage and exposed rotating parts are used in the refrigeration unit. Personal injury can result if power is connected.

a. Testing. (See Figure 1-4)

- (1) Be sure power has been disconnected at the source and remove two bolts (1) and lock washers (2). Open control panel (3) Discard lock washers.
- (2) Remove two six amp fuses (4).
- (3) Using multimeter set to measure continuity, check each fuse (4) continuity between ends. Continuity should be indicated. If no continuity was indicated, replace fuse.
- (4) If no failure was indicated, install two six amp fuses (4).
- (5) Close control panel (3) Install two new lock washers (2) and bolts (1).

b. Removal.

- (1) Be sure power has been disconnected at the source and remove two bolts (1) and lock washers (2). Open control panel (3) Discard lock washers.
- (2) Remove two six amp fuses (4).

NOTE

Terminal hardware is supplied with fuse block.

- (3) Tag wire lead terminals (5) and remove four screws (6), lock washers (7), and wire lead terminals.
- (4) Remove two screws (8) and fuse block (9).

c. Installation.

- (1) Install fuse block (9) and two screws (8).
- (2) Using tags and wiring diagram (fig 1-4), install wire lead terminals (5), four lock washers (7), and screws (6). Remove tags.
- (3) Install two six amp fuses (4).
- (4) Close control panel (3). Install two new lock washers (2) and bolts (1).

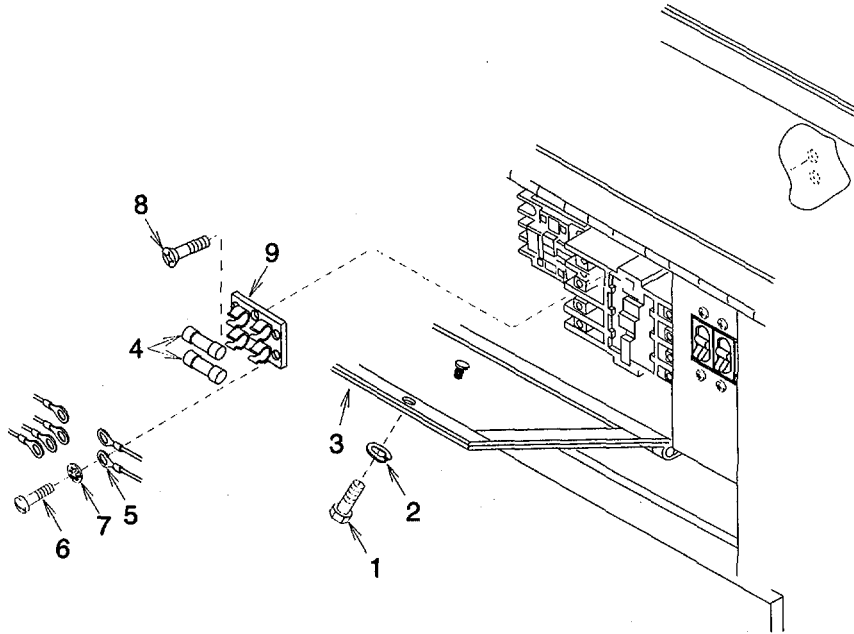

Figure 4-19. Fuses

NOTE

FOLLOW-ON MAINTENANCE:
 Unlatch and close control box cover door.
 Connect power and put unit back into service.

4-25. MOTOR STARTER K1 TESTING, REPAIR, AND REPLACEMENT.

This task covers: a. Testing b. Repair c. Removal d. Installation

INITIAL SETUPMaterials/Parts:

Lock Washers (5)
 1, Appendix G
 Marker tags (11)
 7, Appendix E

Equipment Conditions:

Refrigeration unit shut down (para 2-7) and power disconnected.
 Control box cover door raised and latched.

General Safety Instructions:

WARNING

High voltage and exposed rotating parts are used in the refrigeration unit. Personal injury can result if power is connected.

a. Testing. (See Figure 1-4).

- (1) Be sure power has been disconnected at the source and remove two bolts (1) and lock washers (2). Open control panel (3). Discard lock washers.
- (2) Press and hold plunger (4).
- (3) Using multimeter set to measure continuity, check each motor starter (5) contact continuity between terminals L1 to T1, L2 to T2, and L3 to T3. Continuity should be indicated.
- (4) Release plunger (4).
- (5) If no continuity was indicated, test thermal overload heaters (6) per following step.
- (6) Using multimeter set to measure continuity, check each thermal overload heater (6) continuity between mounting screws. Continuity should be indicated. If no continuity was indicated, replace thermal overload heater to repair motor starter (5) and repeat tests.
- (7) Using multimeter set to measure continuity, check coil continuity between terminals A1 to A2. Continuity should be indicated. If no continuity was indicated, replace motor starter (5).
- (8) Press and release RESET button (7).
- (9) Using multimeter set to measure continuity, check overload contacts between terminals 95 to 96 Continuity should be indicated. If no continuity was indicated, replace motor starter (5).
- (10) Using multimeter set to measure continuity, check each motor starter (5) contact continuity between terminals L1 to T1, L2 to T2, and L3 to T3. No continuity should be indicated. If continuity was indicated, replace motor starter.

(11) If no failure was indicated, close control panel (3). Install two new lock washers (2) and bolts (1).

b. Repair.

(1) Remove defective thermal overload heater (6).

(2) Install thermal overload heater (6).

c. Removal.

(1) Be sure power has been disconnected at the source and remove two bolts (1) and lock washers (2). Open control panel (3). Discard lock washers.

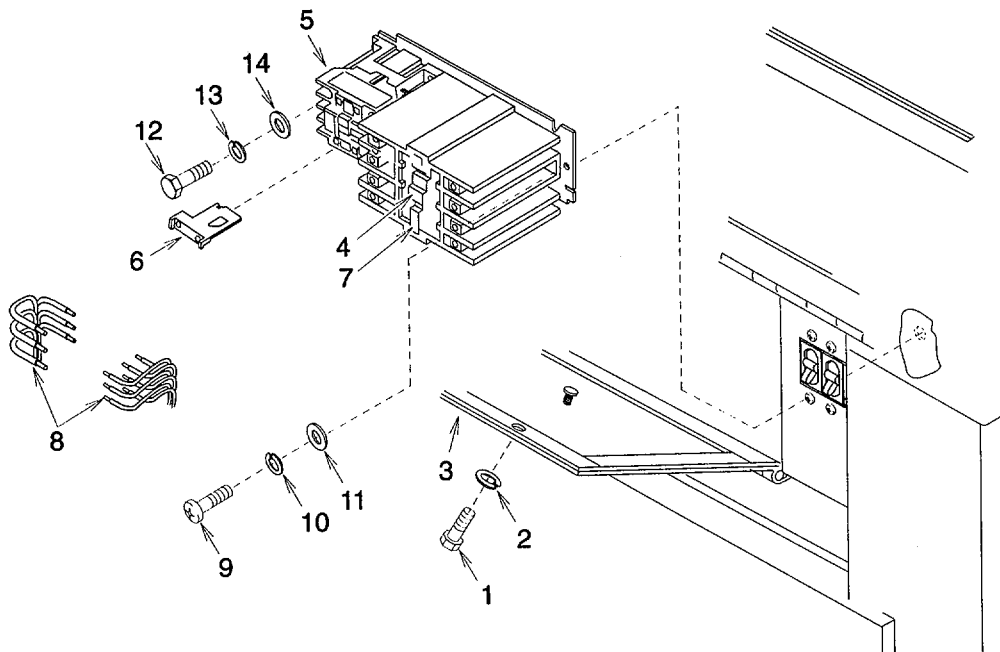

Figure 4-20. Motor Starter

NOTE

Steps 2 through 4 apply only to new motor starter. A new motor starter is configured with jumpers connected for operation at 115 Vac and must be reconnected for use with 208/230 Vac.

(2) Tag and disconnect wire leads (8).

(3) Remove screw (9), lock washer (10), and flat washer (11). Discard lock washer.

(4) Remove two each bolts (12), lock washers (13), and flat washers (14), and motor starter (5). Discard lock washers.

4-25. MOTOR STARTER K1 TESTING, REPAIR, AND REPLACEMENT. -Continuedd. Installation.

- (1) Install three new thermal overload heaters (6) onto new motor starter (5).
- (2) Remove two red wire lead jumpers between terminals L2 to 96 and A1 to 3 Discard jumpers.
- (3) Move red wire lead jumper from between terminals A2 to 95 and place between terminals A1 to 95.
- (4) Set overload adjustment (FLA) dial to A position and (RESET) adjustment dial to M position.
- (5) Install motor starter (5), two flat washers (14), new lock washers (13), and bolts (12).
- (6) Install flat washer (11), new lock washer (10), and screw (9).
- (7) Using tags and wiring diagram (fig 1-4), install wire leads (8). Remove tags.
- (8) Close control panel (3). Install two new lock washers (2) and bolts (1).

NOTE

FOLLOW-ON MAINTENANCE:
Unlatch and close control box cover door.
Connect power and put unit back into service.

4-26. CONTACTOR K2 TESTING AND REPLACEMENT.

This task covers a. Testing b. Removal c. Installation

INITIAL SETUPMaterials/Parts:

Lock Washers (2)
1, Appendix G
Lock Washers (4)
6, Appendix G
Marker tags (9)
7, Appendix E

General Safety Instructions:

WARNING

High voltage and exposed rotating parts are used in the refrigeration unit. Personal injury can result if power is connected.

Equipment Conditions:

Refrigeration unit shut down (para 2-7) and power disconnected.
Control box cover door raised and latched.

a. Testing. (See Figure 1-4)

- (1) Be sure power has been disconnected at the source and remove two bolts (1) and lock washers (2). Open control panel (3). Discard lock washers.
- (2) Press and hold plunger (4).
- (3) Using multimeter set to measure continuity, check each contactor (5) contact continuity between terminals L1 to T1, L2 to T2, and L3 to T3. Continuity should be indicated.
- (4) Release plunger (4).
- (5) If no continuity was indicated, replace contactor (5).
- (6) Using multimeter set to measure continuity, check coil continuity between terminals A1 to A2. Continuity should be indicated. If no continuity was indicated, replace contactor (5).
- (7) Using multimeter set to measure continuity, check each contactor (5) contact continuity between terminals L1 to T1, L2 to T2, and L3 to T3. No continuity should be indicated. If continuity was indicated, replace contactor.
- (8) If no failure was indicated, close control box cover (3) and install two new lock washers (2) and bolts (1).

4-26. CONTACTOR K2 TESTING AND REPLACEMENT.-Continuedb. Removal.

- (1) Be sure power has been disconnected at the source and remove two bolts (1) and lock washers (2). Open control panel plate (3) Discard lock washers.
- (2) Tag and disconnect wire leads (6).
- (3) Remove four bolts (7), lock washers (8), flat washers (9), and contactor (5). Discard lock washers.

c. Installation.

- (1) Install contactor (5), four flat washers (9), new lock washers (8), and bolts (7).
- (2) Using tags and wiring diagram (fig. 1-4), install wire leads (6). Remove tags.
- (3) Close control panel (3). Install two new lock washers (2) and bolts (1).

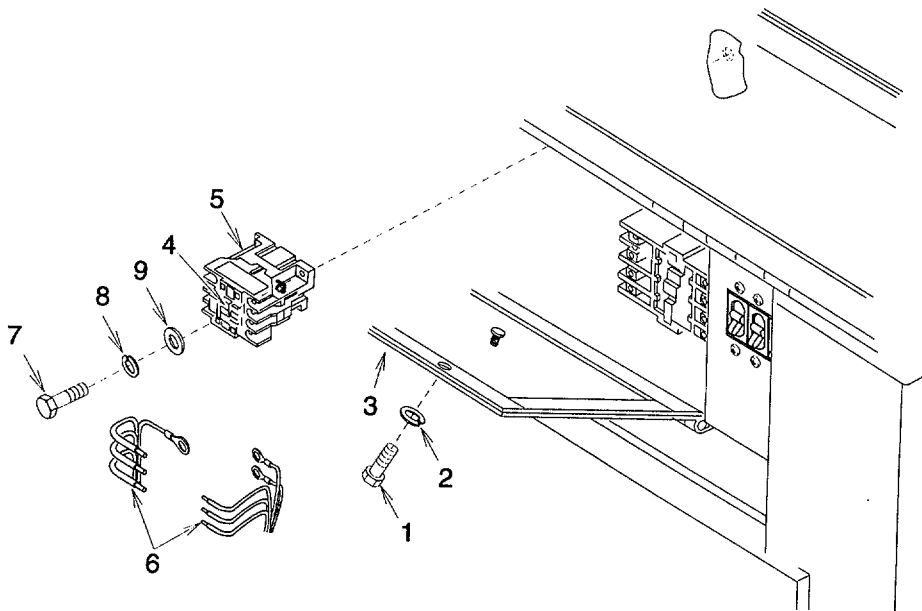

Figure 4-21. Contactor

NOTE

FOLLOW-ON MAINTENANCE:
 Unlatch and close control box cover door.
 Connect power and put unit back into service.

4-27. CONTROL RELAYS K3 AND K4 TESTING AND REPLACEMENT.

This task covers. a.. Testing b. Removal c. Installation

INITIAL SETUP

Tools:

Heat Gun
4, Section III, Appendix B

Materials/Parts:

Lock Washers (2)
1, Appendix G
Lock Washer (1) (K3)
6, Appendix G
Lock Washer (1) (K4)
6, Appendix G
Sleeving Insulation (3) (K3)
3, Figure F-3, Appendix F
Sleeving Insulation (2) (K4)
3, Figure F-3, Appendix F
Marker tags (4) (K3)
7, Appendix E
Marker tags (6) (K3)
7, Appendix E

Equipment Conditions:

Refrigeration unit shut down (para 2-7) and power disconnected.
Control box cover open.

General Safety Instructions:

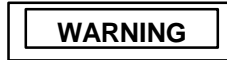

High voltage and exposed rotating parts are used in the refrigeration unit . Personal injury can result if power is connected.

a. Testing. (See Figure 1-4)

- (1) Be sure power has been disconnected at the source and remove two bolts (1) and lock washers (2). Open control panel (3). Discard lock washers.
- (2) Using multimeter set to measure continuity, check each control relay (4) coil continuity between terminals A to B. Continuity should be indicated. If no continuity was indicated, replace control relay.
- (3) Using multimeter set to measure continuity, check each control relay (4) contact continuity between terminals 7 to 4 (K3 and K4) and 9 to 6 (K4). No continuity should be indicated. If continuity was indicated, replace control relay (4).
- (4) If no failure was indicated, close control panel (3). Install two new lock washers (2) and bolts (1).

4-27. CONTROL RELAYS K3 AND K4 TESTING AND REPLACEMENT. -Continuedb. Removal.

(1) Be sure power has been disconnected at the source and remove two bolts (1) and lock washers (2). Open control panel (3). Discard lock washers.

NOTE

The following procedures apply to both control relays K3 and K4
Quantities given are for each relay.

(2) Tag and disconnect wire leads (5). Do not remove sleeving insulation (6) or faston tab adapters (7) unless terminals are damaged.

(3) Remove bolt (8), lock washer (9), flat washer (10), and control relay (4) Discard lock washer.

c. Installation.**NOTE**

The following procedures apply to both control relays K3 and K4
Quantities given are for each relay

(1) Install control relay (4), flat washer (10), new lock washer (9), and bolt (8).

(2) If wire lead (5) terminals were damaged, repair per paragraph 4-20.

(3) If sleeving insulation (6) is damaged or was removed, replace it.

(a) Using tags and wiring diagram (fig. 1-4), connect wire leads (5) to faston tab adapter (7).

(b) Place sleeving insulation (6) over faston tab adapter (7) and wire lead (5) terminals.

(c) Shrink sleeving insulation (6) in place using heat gun.

(4) Using tags and wiring diagram (fig 14), install wire leads (5). Remove tags.

(5) Close control panel (3). Install two new lock washers (2) and bolts (1).

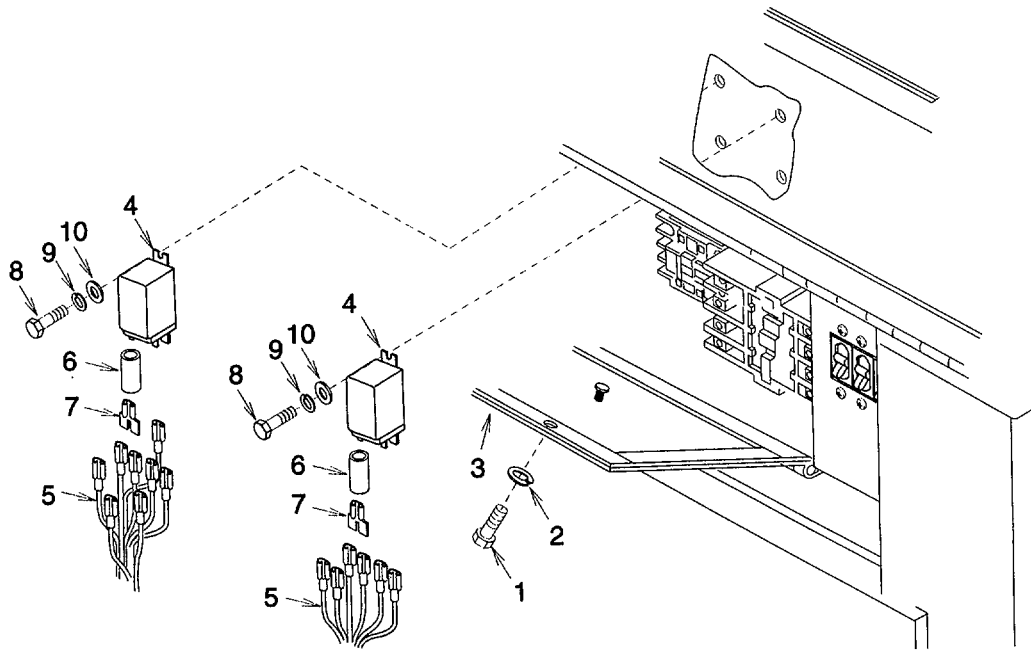

Figure 4-22. Control Relays

NOTE

FOLLOW-ON MAINTENANCE:
 Unlatch and close control box cover door.
 Connect power and put unit back into service.

4-28. HOURLMETER M1 TESTING AND REPLACEMENT.

This task covers a Testing b. Removal c Installation

INITIAL SETUP

Materials/Parts:

- Lock Washers (2)
1, Appendix G
- Self Locking Nuts (2)
8, Appendix G
- Marker tags (2)
7, Appendix E

Equipment Conditions:

- Refrigeration unit shut down (para 2-7) and power disconnected.
- Control box cover door raised and latched.

General Safety Instructions

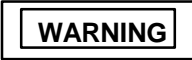

High voltage and exposed rotating parts are used in the refrigeration unit. Personal injury can result if power is connected.

a. Testing. (See Figure 1-4)

- (1) Be sure power has been disconnected at the source and remove two bolts (1) and lock washers (2). Open control panel (3). Discard lock washers.
- (2) Using multimeter set to measure continuity, check hourmeter (4) continuity between terminals 1 to 2. Continuity should be indicated. If no continuity was indicated, replace hourmeter.
- (3) If no failure was indicated, close control panel (3). Install two new lock washers (2) and bolts (1).

b. Removal.

- (1) Be sure power has been disconnected at the source and remove two bolts (1) and lock washers (2). Open control panel (3) . Discard lock washers.

NOTE

Terminal hardware is supplied with hourmeter.

- (2) Tag wire leads (5) and remove two screws (6), lock washers (7), and wire leads.
 - (3) Remove two self locking nuts (8), bolts (9), and hourmeter (4). Discard self locking nuts.
- c. Installation.
- (1) Install hourmeter (4), two bolts (9), and new self locking nuts (8).
 - (2) Using tags and wiring diagram (fig. 1-4), install wire leads (5), two lock washers (7), and screws (6). Remove tags.
 - (3) Close control panel (3) Install two new lock washers (2) and bolts (1).

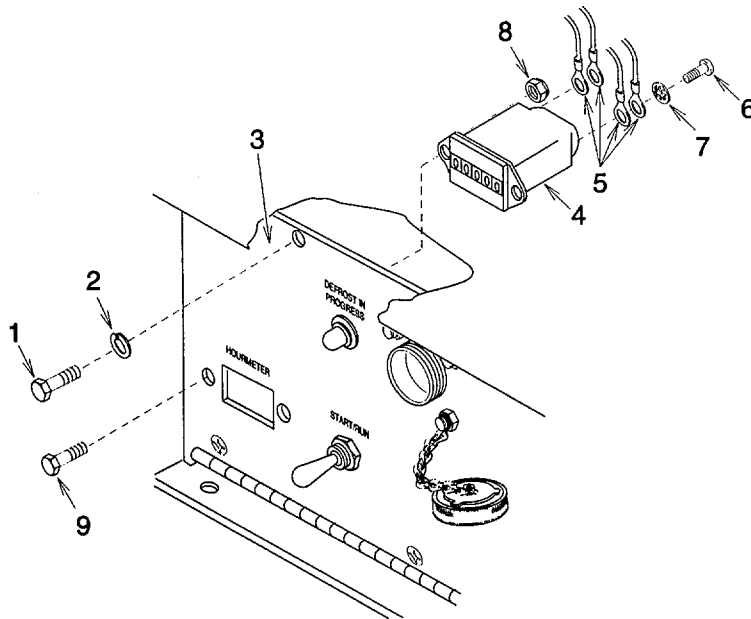

Figure 4-23. Hourmeter

NOTE

FOLLOW-ON MAINTENANCE:
 Unlatch and close control box cover door.
 Connect power and put unit back into service.

4-29. TOGGLE SWITCH S1 TESTING AND REPLACEMENT.

This task covers a. Testing b Removal c. Installation

INITIAL SETUP

Materials/Parts:

- Lock Washers (2)
1, Appendix G
- Marker tags (2)
7, Appendix E

Equipment Conditions:

Refrigeration unit shut down (para 2-7) and power disconnected.
Control box cover door raised and latched.

General Safety Instructions:



High voltage and exposed rotating parts are used in the refrigeration unit. Personal injury can result if power is connected.

a. Testing. (See Figure 1-4.)

- (1) Be sure power has been disconnected at the source and remove two bolts (1) and lock washers (2). Open control panel (3) Discard lock washers.
- (2) Using multimeter set to measure continuity, check toggle switch (4) continuity between terminals 2 to 3 with toggle switch in both START/RUN and OFF position. Continuity should be indicated only when toggle switch (4) is in the START/RUN position. If continuity was indicated in the OFF position or if no continuity was indicated in the START/RUN position, replace toggle switch (4).
- (3) If no failure was indicated, close control panel (3). Install two new lock washers (2) and bolts (1).

b. Removal.

- (1) Be sure power has been disconnected at the source and remove two bolts (1) and lock washers (2). Open control panel (3). Discard lock washers.

NOTE

Terminal and mounting hardware is supplied with toggle switch.

- (2) Tag wire leads (5) and remove two screws (6), lock washers (7), and wire leads.
- (3) Remove nut (8), lock washer (9), retainer (10), and toggle switch (4).

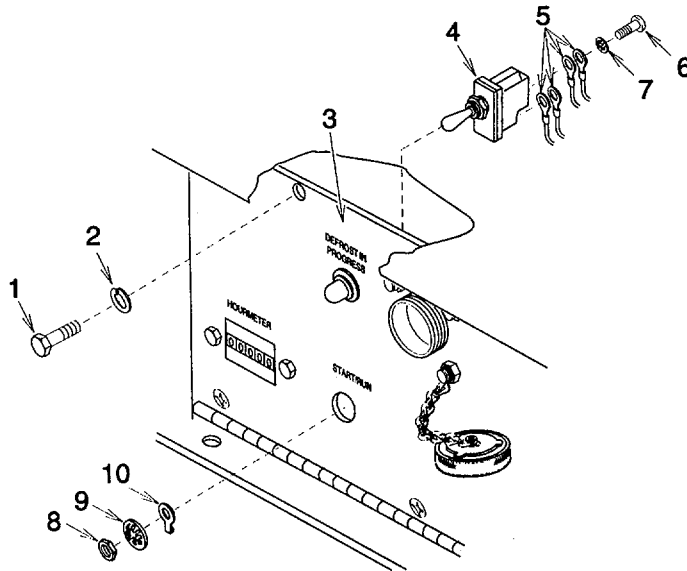

Figure 4-24. Toggle Switch

c. Installation.

- (1) Install toggle switch (4), retainer (10), lock washer (9), and nut (8).
- (2) Using tags and wiring diagram (fig. 1-4), install wire leads (5), two lock washers (7), and screws (6). Remove tags.
- (3) Close control panel (3) Install two new lock washers (2) and bolts (1).

NOTE

FOLLOW-ON MAINTENANCE:
 Unlatch and close control box cover door.
 Connect power and put unit back into service.

4-30. REPEAT CYCLE TIMER TM1 TESTING AND REPLACEMENT.

This task covers a Testing b Removal c Installation

INITIAL SETUP

Materials/Parts:

- Lock Washers (2)
1, Appendix G
- Self Locking Nut (2)
8, Appendix G
- Tie Down Strap
23, Appendix E
- Marker tags (7)
7, Appendix E

Equipment Conditions:

- Refrigeration unit shut down (para 2-7) and power disconnected.
- Control box cover door raised and latched.

General Safety Instructions:

WARNING

High voltage and exposed rotating parts are used in the refrigeration unit. Personal injury can result if power is connected.

a. Testing. (See Figure 1-4)

- (1) Be sure power has been disconnected at the source and remove two bolts (1) and lock washers (2). Open control panel (3) Discard lock washers.
- (2) Remove and discard tie down strap (4).
- (3) Pull repeat cycle timer (5) from relay mounting socket (6).
- (4) Using multimeter set to measure continuity, check repeat cycle timer (5) continuity between terminals 1 to 7. Continuity should be indicated. If no continuity was indicated, replace repeat cycle timer.
- (5) Using multimeter set to measure continuity, check repeat cycle timer (5) continuity between terminals 4 to 7 and 6 to 9. No continuity should be indicated If continuity was indicated, replace repeat cycle timer.
- (6) If relay mounting socket (6) is damaged, replace it.
- (7) If no failure was indicated, push repeat cycle timer (5) into relay mount socket (6) and install new tie down strap (4).
- (8) If no failure was indicated, close control panel (3) Install two new lock washers (2) and bolts (1).

b. Removal.

- (1) Be sure power has been disconnected at the source and remove two bolts (1) and lock washers (2). Open control panel plate (3). Discard lock washers.
- (2) Remove and discard tie down strap (4).
- (3) Pull repeat cycle timer (5) from relay mounting socket (6).

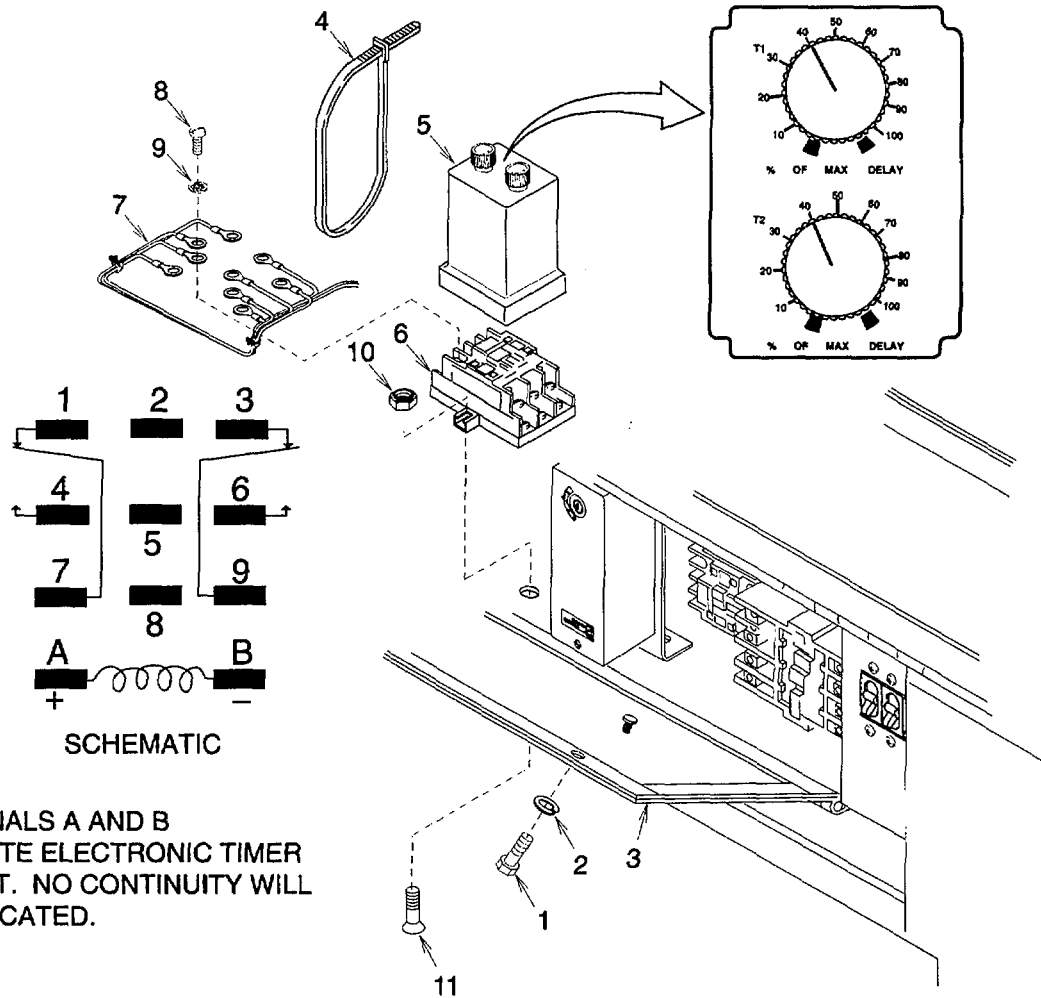

Figure 4-25. Repeat Cycle Timer

4-30. REPEAT CYCLE TIMER TM1 TESTING AND REPLACEMENT. - Continued**NOTE**

Terminal hardware is supplied with repeat cycle timer

- (4) Tag wire lead terminals (7) and remove seven screws (8), lock washers (9), and wire lead terminals
- (5) Remove two self locking nuts (10), screws (11), and relay mounting socket (6) Discard self locking nuts

c Installation

- (1) Install relay mounting socket (6), two screws (11), and new self locking nuts (10).
- (2) Using tags and wiring diagram (fig 1-4), install wire lead terminals (7), seven lock washers (9), and screws (8) Remove tags
- (3) Push repeat cycle timer (5) into relay mount socket (6) and install new tie down strap (4)
- (4) Adjust controls (para 4-8) as necessary
- (5) Close control panel (3) Install two new lock washers (2) and bolts (1)

NOTE

FOLLOW-ON MAINTENANCE
Unlatch and close control box cover door
Connect power and put unit back into service.

4-31. REMOTE BULB THERMOSTAT S3 TESTING AND REPLACEMENT.

This task covers: a. Testing b. Removal c. Installation

INITIAL SETUPMaterials/Parts

Lock Washers (5)
 1, Appendix G
 Self Locking Nut
 8, Appendix G
 Self Locking Nuts (2)
 11, Appendix G

 Self Locking Nut
 12, Appendix G
 Tie Down Straps
 24, Appendix E
 Marker tags (2)
 7, Appendix E
 Silicone RTV
 20, Appendix E

Equipment Conditions

Refrigeration unit shut down (para 2-7) and power disconnected
 Control panel cover door raised and latched
 Left side door open
 Cover panel removed (para 4-16)

General Safety Instructions**WARNING**

High voltage and exposed rotating parts are used in the refrigeration unit. Personal injury can result if power is connected.

a. Testing (See Figure 1-4.)

- (1) Be sure power has been disconnected at the source and remove two bolts (1) and lock washers (2). Open control panel (3). Discard lock washers.
- (2) Remove screw (4) and cover (5).
- (3) Remove two bolts (6), lock washers (7), flat washers (8), and sensing bulb bracket (9). Discard lock washers.
- (4) Remove self locking nut (10), lock washer (11), bolt (12), from sensing bulb bracket (9). Discard self locking nut and lock washer.
- (5) Remove clamp (13).
- (6) Immerse sensing bulb (14) into a temperature controlled bath at 32° F (0° C). A bath at this temperature can be made by putting the sensing bulb into a container of ice and covering with water. Ice must remain packed around sensing bulb at all times during test.
- (7) Using multimeter set to measure continuity, check remote bulb thermostat (15) continuity between terminals 1 and 3 with thermostat setting at 24° F (-4° C) and at 40° F (40 C). Continuity should be indicated only when the setting is at 24° F (-4° C). If continuity was indicated at 40° F (4° C) setting, replace thermostat.
- (8) If no failure was indicated, slip clamp (13) over sensing bulb (14).

4-31. REMOTE BULB THERMOSTAT S3 TESTING AND REPLACEMENT. - Continued

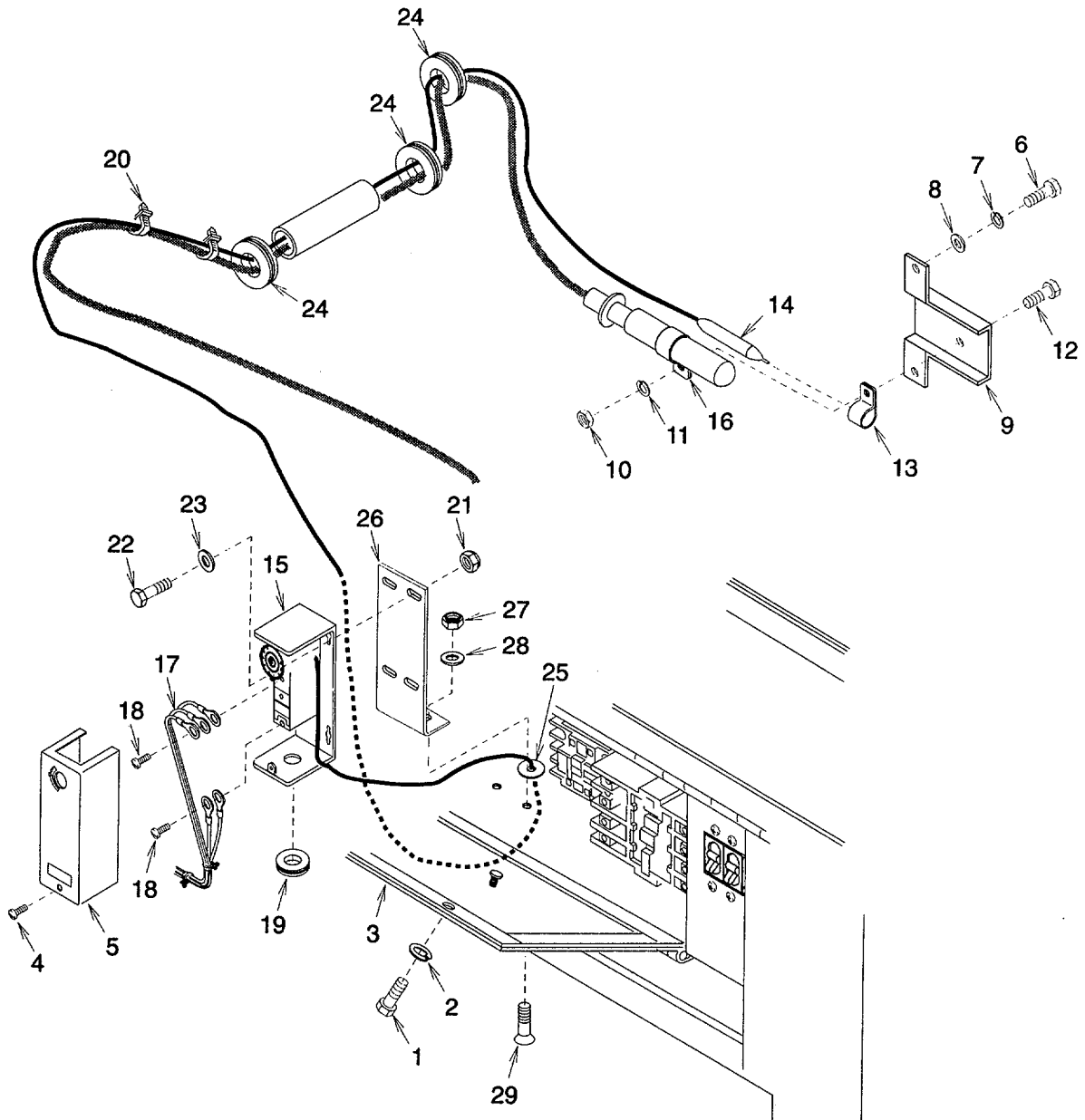

Figure 4-26. Remote Bulb Thermostat (Temperature Control)

- (9) Install clamps (13) and (16), bolt (12), new lock washer (11) and new self locking nut (10)
- (10) Install sensing bulb bracket (9), two flat washer (8), new lock washers (7), and bolts (6)
- (11) Install cover (5) and screw (4)
- (12) Close control panel (3) Install two new lock washers (2) and bolts (1)

b Removal

- (1) Be sure power has been disconnected at the source and remove two bolts (1) and lock washers (2) Open control panel (3) Discard lock washers
- (2) Remove screw (4) and cover (5)
- (3) Remove two bolts (6), lock washers (7), flat washers (8), and sensing bulb bracket (9) Discard self locking nuts and lock washer
- (4) Remove self locking nut (10), lock washer (11), bolt (12), and sensing bulb bracket (9) Discard self locking nut and lock washer
- (5) Remove clamps (13)
- (6) Tag wire leads (17), then remove two screws (18) and wire leads
- (7) Pull wire leads (17) from remote bulb thermostat (15) and remove grommet (19)
- (8) Remove tie down straps (20).
- (9) Remove four self locking nuts (21), bolts (22), and flat washers (23) Discard self locking nuts
- (10) Remove remote bulb thermostat (15) and any grommets (24) and (25) necessary to remove sensing bulb (14)
- (11) If temperature control switch bracket (26) is damaged, remove two self locking nuts (27), flat washers (28), screws (29), and bracket. Discard self locking nuts
- (12) Remove any silicone RTV remaining in grommets (24)

c Installation

- (1) If removed, install temperature control bracket (26), two screws (29), flat washers (28), and new self locking nuts (27)
- (2) Install remote bulb thermostat (15) routing sensing bulb (14) through grommets (24) and (25) Install any grommets removed.
- (3) Install remote bulb thermostat (15), four flat washers (23), bolts (22), and new self locking nuts (21)
- (4) Install tiedown straps (20) as necessary.
- (5) Install grommet (19) and push wire leads (17) into remote bulb thermostat (15)
- (6) Using tags and wiring diagram (fig 1-4), install wire leads (17) and two screws (18) Remove tags

4-31. REMOTE BULB THERMOSTAT S3 TESTING AND REPLACEMENT. - Continued

- (7) Slip clamp (13) over sensing bulb (14)
- (8) Install clamps (13) and (16), bolt (12), new lock washer (11) and new self locking nut (10).
- (9) Install sensing bulb bracket (9), two flat washers (8), new lock washers (7) and bolts (6)
- (10) Install cover (5) and screw (4)
- (11) Close control panel (3) Install two new lock washers (2) and bolts (1).
- (12) Apply silicone RTV into grommets (24) to seal evaporator enclosure.

NOTE

FOLLOW-ON MAINTENANCE.
Unlatch and close control panel cover door
Close left side door.
Install cover panel (para 4-16)
Connect power and put unit back into service.

4-32. TERMINAL BOARD TB1 REPLACEMENT.

This task covers. a. Removal b. Installation

INITIAL SETUPMaterials/Parts.

Lock Washers (4)
1, Appendix G
Self Locking Nuts (2)
14, Appendix G
Marker tags (4)
7, Appendix E
7, Appendix E

Equipment Conditions

Refrigeration unit shut down (para 2-7) and power disconnected
Control box cover door raised and latched
Right side door open

General Safety Instructions**WARNING**

High voltage and exposed rotating parts are used in the refrigeration unit. Personal injury can result if power is connected.

a. Removal

- (1) Be sure power has been disconnected at the source and remove two bolts (1) and lock washers (2) Open control panel (3) Discard lock washers
- (2) Remove two bolts (4) and lock washers (5) Discard lock washers.
- (3) Carefully pull circuit breaker cover (6) out as far as possible.
- (4) Tag wire leads (7) Remove four screws (8) and disconnect wire leads.
- (5) Remove two self locking nuts (9), screws (10), wire leads (7), and terminal board (11).

b. Installation

- (1) Install terminal board (11), two screws (10), wire leads (7) using tags and wiring *diagram (fig 1-4)*, and new self locking nuts (9)
- (2) Using tags and wiring diagram (fig. 1-4), connect wire leads (7) and secure with four screws (8) Remove tags
- (3) Carefully push circuit breaker cover (6) into place and install two new lock washers (5) and bolts (4)
- (4) Close control panel (3) Install two new lock washers (2) and bolts (1)

4-32. TERMINAL BOARD TB1 REPLACEMENT. - Continued

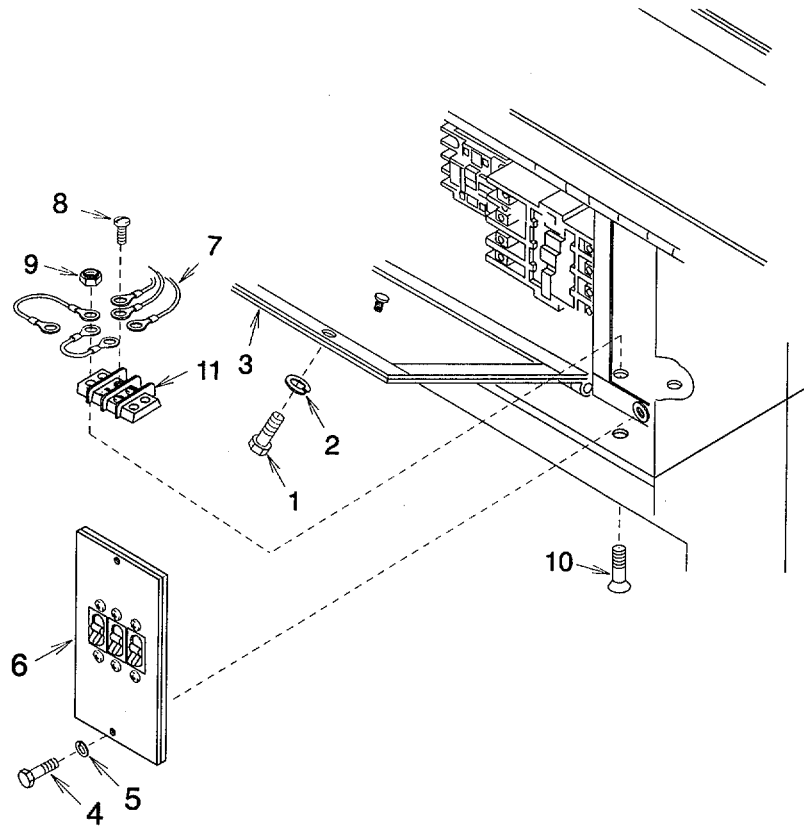

Figure 4-27. Terminal Board TB1

NOTE

FOLLOW-ON MAINTENANCE
Unlatch and close control box cover door
Connect power and put unit back into service

4-33. GROUND STRAP (CONTROL BOX ASSEMBLY) REPLACEMENT.

This task covers: a. Removal b. Installation

INITIAL SETUP

Materials/Parts

Lock Washers (2)
1, Appendix G
Self Locking Nuts (2)
Self Locking Nuts (2)
14, Appendix G

General Safety Instructions,

WARNING

High voltage and exposed rotating parts are used in the refrigeration unit. Personal injury can result if power is connected.

Equipment Conditions

Refrigeration unit shut down (para 2-7) and power disconnected
Control box cover door raised and latched

a. Removal

- (1) Be sure power has been disconnected at the source and remove two bolts (1) and lock washers (2). Open control panel (3). Discard lock washers.
- (2) Remove two self locking nuts (4), screws (5), and ground strap (6). Discard self locking nut.

b. Installation

- (1) Install ground strap (6), two screws (5), and new self locking nuts (4).
- (2) Close control panel (3). Install two new lock washers (2) and bolts (1).

4-33. GROUND STRAP (CONTROL BOX ASSEMBLY) REPLACEMENT. - Continued

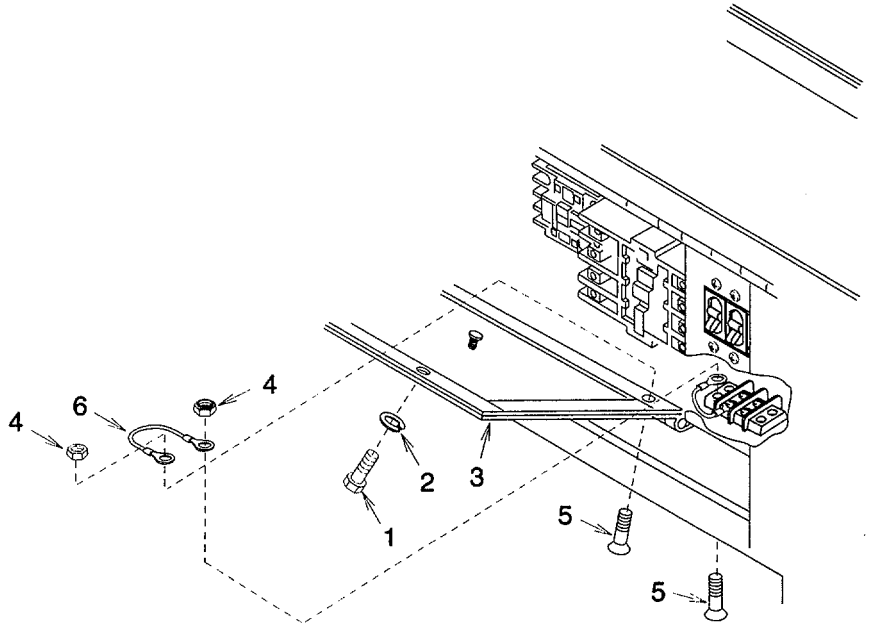

Figure 4-28. Ground Strap (Control Panel)

NOTE

FOLLOW-ON MAINTENANCE

Unlatch and close control box cover door.
Connect power and put unit back into service

4-34. DUMMY STOWAGE CONNECTOR AND COVER REPLACEMENT.

This task covers: a. Removal b. Installation

INITIAL SETUP

Materials/Parts

- Lock Washers (2)
- 1, Appendix G
- Self Locking Nuts (4)
- 8, Appendix G

Equipment Conditions

Refrigeration unit shut down (para 2-7) and power disconnected.
Control box cover door raised and latched.

General Safety Instructions

WARNING

High voltage and exposed rotating parts are used in the refrigeration unit. Personal injury can result if power is connected

a. Removal.

- (1) Be sure power has been disconnected at the source and remove two bolts (1) and lock washers (2) Open control panel (3). Discard lock washers
- (2) Remove four self locking nuts (4), bolts (5), cover (6), and dummy stowage connector (7) Discard self locking nuts

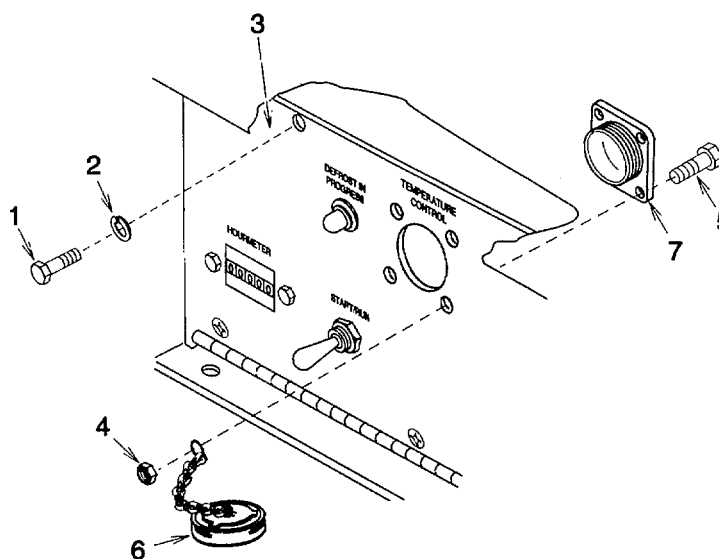

Figure 4-29. Dummy Stowage Connector and Cover

4-34. DUMMY STOWAGE CONNECTOR AND COVER REPLACEMENT. - Continued

b. Installation.

- (1) Install dummy stowage connector (7), four bolts (5), new self locking nuts (4) and cover (6)
- (2) Close control panel (3). Install two new lock washers (2) and bolts (1)

NOTE

FOLLOW-ON MAINTENANCE:
Unlatch and dose control box cover door.
Connect power and put unit back into service

4-35. RESET BUTTON REPLACEMENT.

This task covers: a. Removal b. Installation

INITIAL SETUP

Materials/Parts.

Lock Washers (2)
1, Appendix G

Equipment Conditions.

Refrigeration unit shut down (para 2-7) and power disconnected
Control box cover door raised and latched.

General Safety Instructions,

WARNING

High voltage and exposed rotating parts are used in the refrigeration unit. Personal injury can result if power is connected

a. Removal

- (1) Be sure power has been disconnected at the source and remove two bolts (1) and lock washers (2). Open control panel (3). Discard lock washers.

NOTE

Mounting hardware is supplied with reset button.

- (2) Remove self locking nut (4) and remove reset button (5).

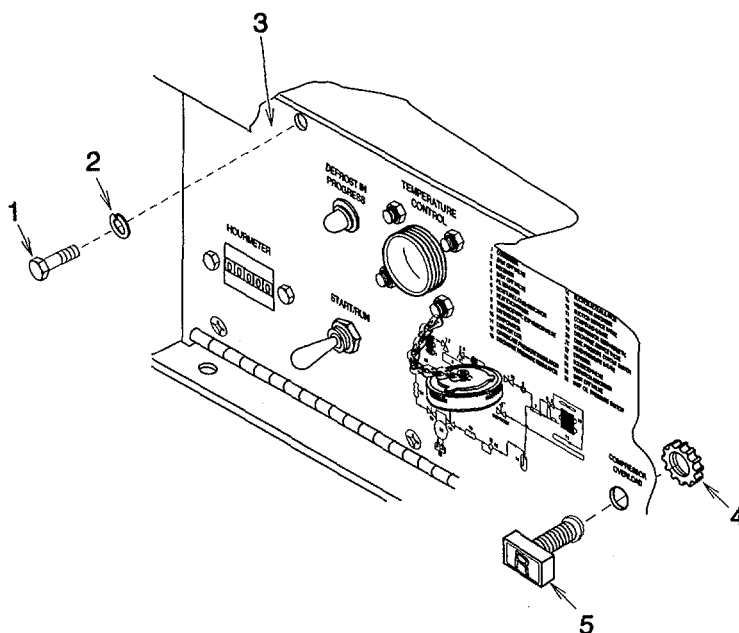

Figure 4-30. Reset Button

4-35. RESET BUTTON REPLACEMENT. - Continued

b. Installation.

NOTE

Mounting hardware is supplied with reset button

- (1) Install reset button (5) and self locking nut (4).
- (2) Close control panel (3). Install two new lock washers (2) and bolts (1).

NOTE

FOLLOW-ON MAINTENANCE.
Unlatch and close control box cover door.
Connect power and put unit back into service.

4-36. POWER DISTRIBUTION BLOCK TB2 REPLACEMENT.

This task covers: a. Removal b. Installation

INITIAL SETUPMaterials/Parts

Lock Washers (4)
13, Appendix G
Self Locking Nuts (4)
14, Appendix G
Marker Tags (9)
7, Appendix E

Equipment Conditions

Refrigeration unit shut down (para 2-7) and power disconnected.
Right side door open
Enclosure assembly door open

General Safety Instructions:**WARNING**

High voltage and exposed rotating parts are used in the refrigeration unit. Personal injury can result if power is connected

a. Removal.

- (1) Be sure power has been disconnected at the source and tag wire leads (1).

NOTE

Terminal hardware is supplied with power distribution block.

- (2) Remove screw (2), lock washer (3), and disconnect wire leads (1)
- (3) Be sure wire leads (1) are disconnected then pull wires from strain relief bushings (4) Loosen bushings as necessary
- (4) Remove four bolts (5), lock washers (6), flat washers (7) and enclosure (8) Discard lock washers.
- (5) Remove four self locking nuts (9), screws (10) and power distribution block (11) Discard self locking nuts.
- (6) Remove two lock nuts (12) and strain relief bushings (4)

b. Installation

- (1) Install two strain relief bushings (4), and lock nuts (12)
- (2) Install power distribution block (11), four screws (10), and new self locking nuts (9).
- (3) Install enclosure assembly (8), four flat washers (7), new lock washers (6), and bolts (5).
- (4) Push wire leads (1) through strain relief bushings (4) Tighten bushings.

4-36. POWER DISTRIBUTION BLOCK TB2 REPLACEMENT. - Continued

NOTE

Terminal hardware is supplied with distribution block.

- (5) Using tags and wiring diagram (fig 1-4), connect wire leads (1) to power distribution block (11) and ground stud using screw (2), and lock washer (3) Remove tags

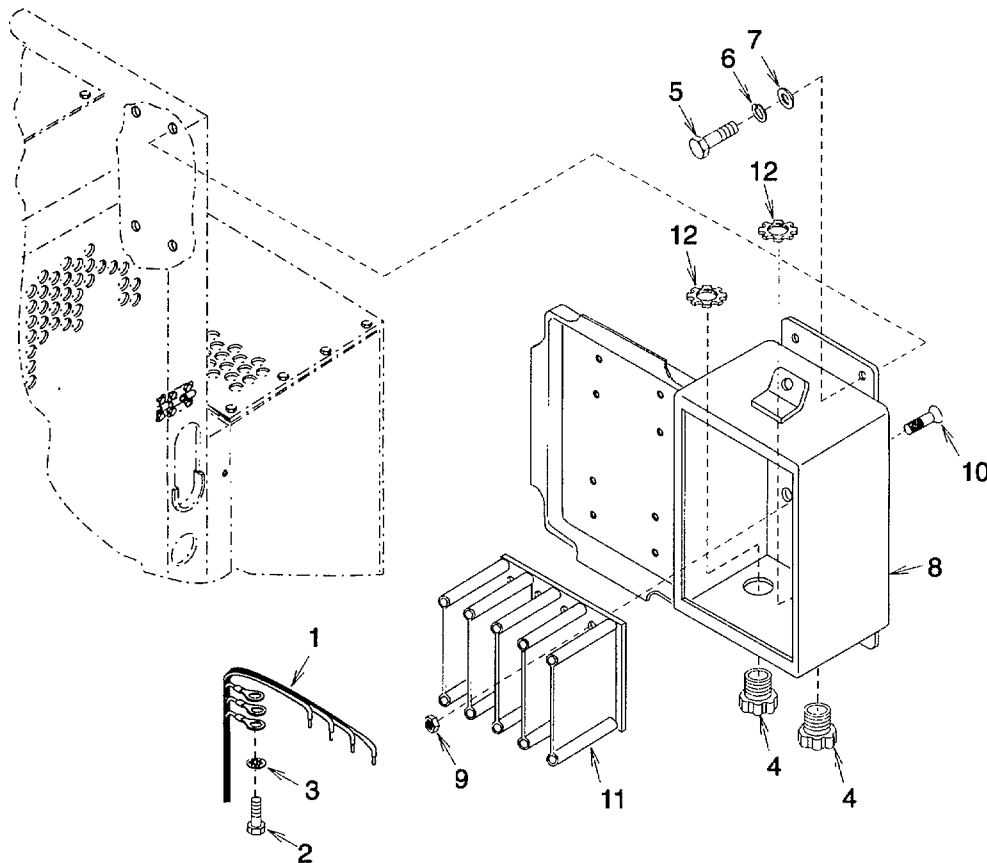

Figure 4-31. Power Distribution Block

NOTE

FOLLOW-ON MAINTENANCE:
 Close enclosure assembly door
 Close right side door.
 Connect power and put unit back into service

4-37. PUSH SWITCHES S6 AND S7 TESTING AND REPLACEMENT.

This task covers: a. Testing b. Removal c. Installation

INITIAL SETUP

Tools:

Heat Gun
3, Section III, Appendix B

Equipment Conditions.

Refrigeration unit shut down (para 2-7) and power disconnected
Both side doors open.

Materials/Parts.

Self Locking Nuts (2 Each Push Switch)
8, Appendix G
Sleeving Insulation (1 Each Push Switch)
1, Figure F-3, Appendix F
Sleeving Insulation (1 Each Push Switch)
2, Figure F-3, Appendix F
Marker tags (2 Each Push Switch)
7, Appendix E

General Safety Instructions

WARNING

High voltage and exposed rotating parts are used in the refrigeration unit. Personal injury can result if power is connected

a. Testing.

- (1) Remove sleeving insulation (1).
- (2) Tag and disconnect wire leads (2).
- (3) Using multimeter set to measure continuity, check push switch (3) contact continuity across terminals C and NO with the push button switch out and pushed in. Continuity should only *be indicated* with the switch pushed in. If continuity was not indicated when switch was pushed in or was indicated with switch out, replace push switch.

NOTE

Smaller diameter sleeving insulation must go over wire lead connecting to push switch terminal C

- (4) If no failure was indicated, install insulation sleeving (1) over wire leads (2)
- (5) Using tags and wiring diagram (fig. 1-4), connect wire leads (2) Remove tags.

NOTE

Sleeving insulation covers only terminal C on one side of push switch, but must cover both terminals NO and NC on the other side

- (6) Slip sleeving insulation (1) over exposed terminals and shrink in place using heat gun.

4-37. PUSH SWITCHES S6 AND S7 TESTING AND REPLACEMENT. - Continued

b. Removal

- (1) Remove sleeving insulation (1)
- (2) Tag and disconnect wire leads (2)
- (3) Remove two self locking nuts (4), flat washers (5), bolts (6), and push switch (3) Discard self locking nuts.

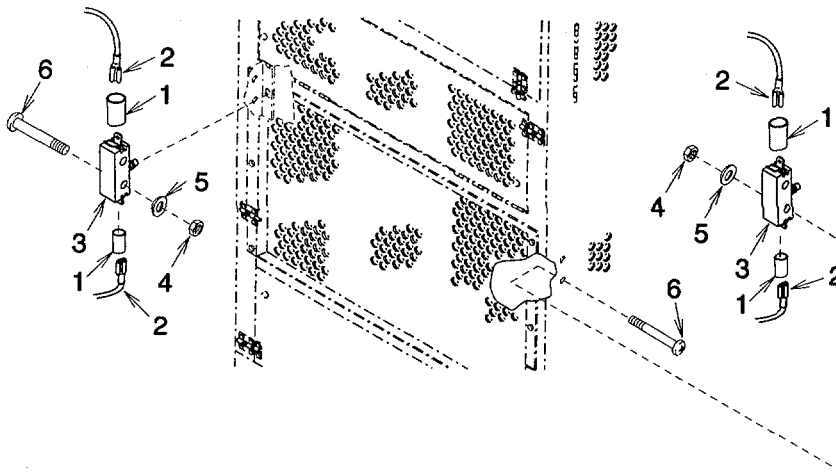

Figure 4-32. Push (Door) Switches

c. Installation

- (1) Install push switch (3), two bolts (6), flat washers (5), and new self locking nuts (4)

NOTE

Smaller diameter sleeving insulation must go over wire lead connecting to push switch terminal C.

- (2) Install insulation sleeving (1) over wire leads (2)
- (3) Using tags and wiring diagram (fig. 1-4), connect wire leads (2) Remove tags.

NOTE

Sleeving insulation covers only terminal C on one side of push switch, but must cover both terminals NO and NC on the other side.

- (4) Slip sleeving insulation (1) over exposed terminals and shrink in place using heat gun.

NOTE

FOLLOW-ON MAINTENANCE.

Close both side doors.

Connect power and put unit back into service.

4-38. V-BELT REPLACEMENT AND ADJUSTMENT.

This task covers: a. Removal b. Installation c. Adjustment

INITIAL SETUPMaterials/Parts

Lock Washers (8)
29, Appendix G

Equipment Conditions:

Refrigeration unit shut down (para 2-7) and power disconnected
Left side door open
Front bottom door open.

General Safety Instructions**WARNING**

High voltage and exposed rotating parts are used in the refrigeration unit Personal injury can result if power is connected

a. Removal

- (1) Remove eight bolts (1), lock washers (2) and remove panel (3)
- (2) Turn self locking nut (4) counterclockwise enough to allow motor mounting plate (5) to be lifted enough to slip V-belt (6) off pulley (7)
- (3) Work V-belt (6) around condenser fan (8)

b. Installation

- (1) Work V-belt (6) around condenser fan (8).
- (2) Slip V-belt (6) over sheave (9) and pulley (7).
- (3) Adjust belt tension

c. Adjustment

- (1) Check alinement of pulley (7) and sheave (9) If they are not alined, loosen set screw (10) and move pulley on AC motor (11) shaft as necessary When alined, tighten set screw
- (2) Turn self locking nut (12) clockwise several turns to allow free travel of motor mount plate (5)
- (3) Turn self locking nut (4) clockwise to increase V-belt (6) tension and counterclockwise to decrease tension V-belt tension is correct when 4 lb (2 kg) force is applied to the mid point of the V-belt and it deflects 3/8 m (1 cm) Turn self locking nut (12) clockwise as necessary to allow motor mount plate (5) travel

4-38. V-BELT REPLACEMENT AND ADJUSTMENT - Continued

- (4) If the V-belt (6) tension cannot be adjusted within the range of motor mount plate (5) travel, loosen four bolts (13) and slide AC motor (11) on motor mount plate as necessary. Be sure pulley (7) and sheave (9) are aligned and tighten four bolts Repeat above step to adjust V-belt tension
- (5) Turn self locking nut (12) counterclockwise against motor mount plate (5).

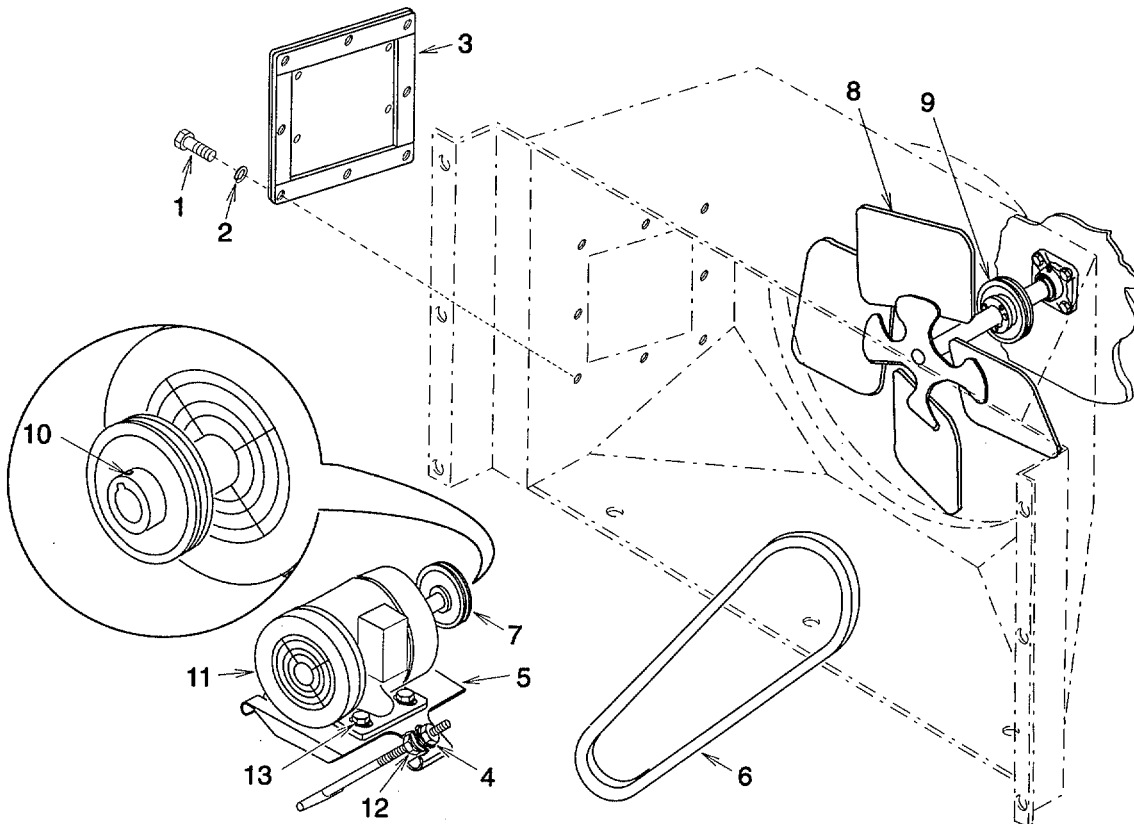

Figure 4-33. V-Belt

NOTE

FOLLOW-ON MAINTENANCE.
 Close left side door.
 Close front bottom door
 Connect power and put unit back into service.

4-39. PULLEY REPLACEMENT.

This task covers: a. Removal b. Installation

INITIAL SETUPEquipment Conditions

Refrigeration unit shut down (para 2-7) and power disconnected

V-belt removed from pulley only (para 4-38)

General Safety Instructions.**WARNING**

High voltage and exposed rotating parts are used in the refrigeration unit. Personal injury can result if power is connected.

- a. Removal Loosen set screw (1) and remove pulley (2) from AC motor (3) shaft being careful not to lose key (4).
- b. Installation Install key (4) then align pulley (2) with key and slide onto AC motor (3) shaft. Tighten set screw (1).

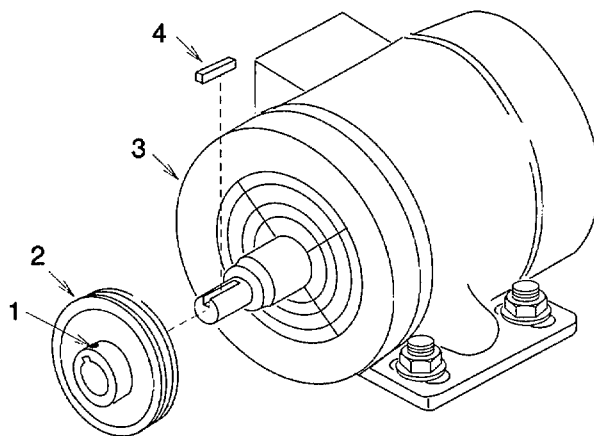

Figure 4-34. Pulley

NOTE

FOLLOW-ON MAINTENANCE
 Install V-belt onto pulley and adjust (para 4-42)
 Connect power and put unit back into service

4-40. GROUND STRAP (MOTOR) REPLACEMENT.

This task covers: a. Removal b. Installation

INITIAL SETUP

Materials/Parts:
 Lock Washers (1)
 7, Appendix G

Equipment Conditions:
 Refrigeration unit shut down (para 2-7) and power disconnected.

General Safety Instructions

WARNING

High voltage and exposed rotating parts are used in the refrigeration unit. Personal injury can result if power is connected.

- a. Removal. Remove bolt (1), lock washer (2), bolt (3), and ground strap (4). Discard lock washer.
- b. Installation. Install ground strap (4), new lock washer (2), bolt (1) and bolt (3).

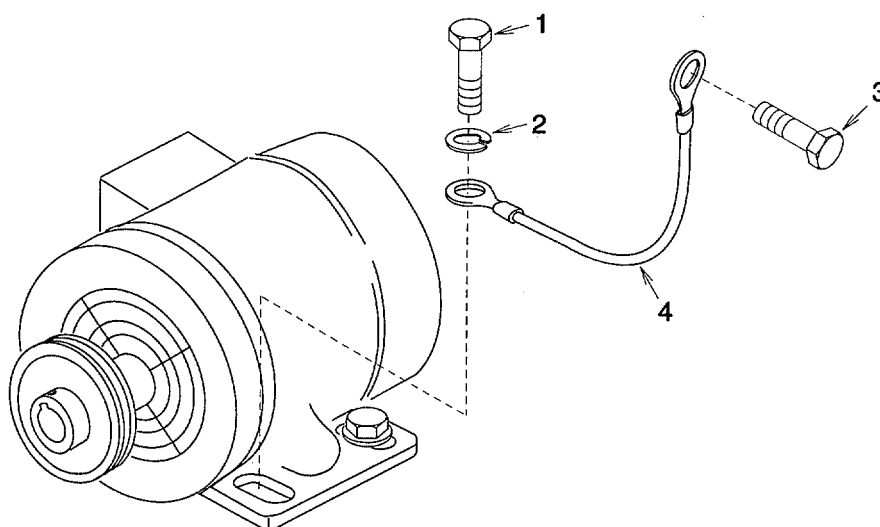

Figure 4-35. Ground Strap (Motor)

NOTE

FOLLOW-ON MAINTENANCE.
 Connect power and put unit back into service

4-41. AC MOTOR B2 TESTING AND REPLACEMENT.

This task covers: a. Testing b. Removal c. Installation

INITIAL SETUPMaterials/Parts:

Lock Washers (4)
7, Appendix G
Self Locking Nuts (2)
17, Appendix G
Cotter pins (2)
10, Appendix G
Marker tags (4)
7, Appendix E

Equipment Conditions:

Refrigeration unit shut down (para 2-7) and power disconnected.
Left side door open.
Front bottom door open.
V-belt removed from pulley only (para 4-38).

General Safety Instructions'**WARNING**

High voltage and exposed rotating parts are used in the refrigeration unit. Personal *injury* can result if power is connected

a. Testing. (See Figure 1-4.)

- (1) Remove four bolts (1) and terminal cover (2).
- (2) Tag and disconnect wire leads (3)
- (3) Check that AC motor (4) winding leads are connected as follows; T4 to T14, T5 to T15, T6 to T16, T1 to T7, T2 to T8, and T3 to T9. If the leads are not connected properly, connect them now.
- (4) Using multimeter set to measure continuity, check AC motor (4) winding continuity between leads T1/T7 to T2/T8, T1/T7 to T3/T9, and T3/T9 to T2/T8. Continuity should be indicated. If continuity was not indicated, replace motor.
- (5) Using multimeter set to measure continuity, check AC motor (4) winding continuity between each lead T1 /T7, T2/T8, and T3/T9 to motor frame ground No continuity should be indicated. If continuity was indicated, replace motor.
- (6) If no failure was indicated, connect wire leads (2) using tags and wiring diagram (fig 1-4). Remove tags.
- (7) Install terminal cover (2) and four bolts (1).

b. Removal.

- (1) Remove four bolts (1) and terminal cover (2).
- (2) Tag and disconnect wire leads (3).
- (3) Remove conduit locknut (5), connector (6), and wire leads (3).

4-41. AC MOTOR B2 TESTING AND REPLACEMENT. - Continued

- (4) Remove four bolts (7), lock washers (8), and ground strap (9) Remove AC motor (4) through front bottom door Discard lock washers
- (5) Loosen setscrew (10) and remove pulley (11) and key (12)
- (6) If motor plate (13) must be replaced, remove self locking nut (14), flat washer (15), two cotter pins (16), flat washers (17), motor mount hinge pm (18), motor mount plate, flat washers (19), and self locking nut (20) Discard self locking nuts and cotter pins

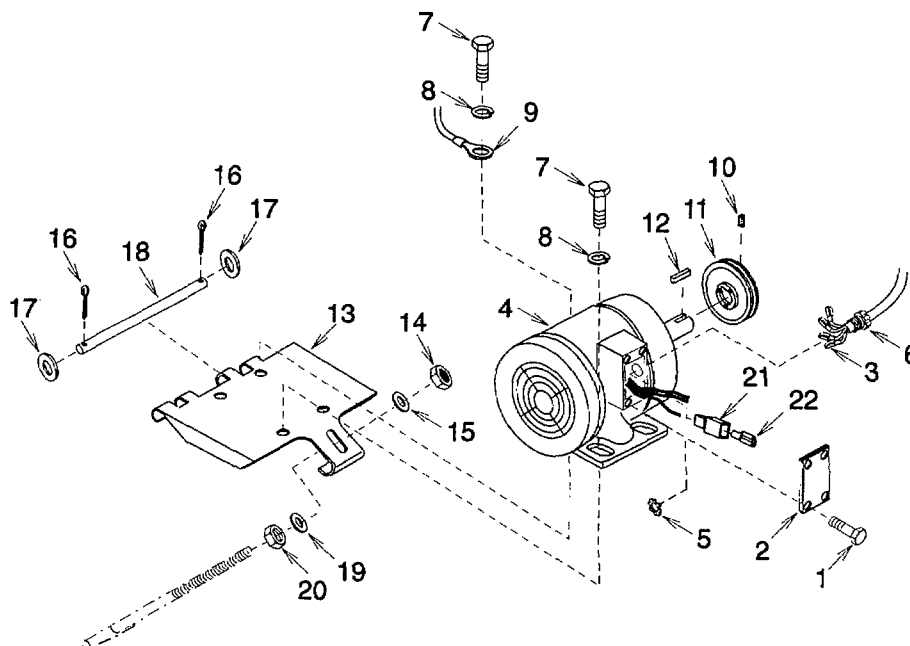

Figure 4-36. AC Motor

c. Installation

- (1) If motor mount plate (13) was removed, install new self locking nut (20), flat washer (19), motor mount plate, motor mount hinge pm (18), two flat washers (17), new cotter pins (16), flat washer (15), and new self locking nut (14).
- (2) Install one new tab housing (21) and tab (22) onto each pair of new AC motor (4) wire leads T1/T7, T2/T8, and T3/T9 (para 4-20)
- (3) Install key (12) and pulley (11) Tighten set screw (10).
- (4) Install AC motor (4), ground strap (9), four new lock washers (8), and bolts (7)

- (5) Install wire leads (3), connector (6), and connector locknut (5).
- (6) Using tags and wiring diagram (fig. 1-4), connect wire leads (3).
- (7) Install terminal cover (2) and four bolts (1)

NOTE

FOLLOW-ON MAINTENANCE:
Install V-belt onto pulley and adjust (para 4-38).
Close left side door.
Close front bottom door.
Connect power and put unit back into service.

4-42. CONDENSER FAN REPLACEMENT.

This task covers: a. Removal b. Installation

INITIAL SETUP

Materials/Parts

Lock Washers (8)

1, Appendix G

Marker tags (4)

7, Appendix E

Equipment Conditions

Refrigeration unit shut down (para 2-7) and power

disconnected

Left side door open

General Safety Instructions

WARNING

High voltage and exposed rotating parts are used in the refrigeration unit. Personal injury can result if power is connected.

a. Removal

(1) Remove eight bolts (1), lock washers (2) and cover (3). Discard lock washers.

(2) Loosen two set screws (4)

(3) Carefully pull condenser fan (5) off fan drive shaft (6)

b. Installation

(1) Align and install condenser fan (5) onto fan drive shaft (6).

(2) Tighten two set screws (4)

(3) Install cover (3), eight bolts (1), and new lock washers (2)

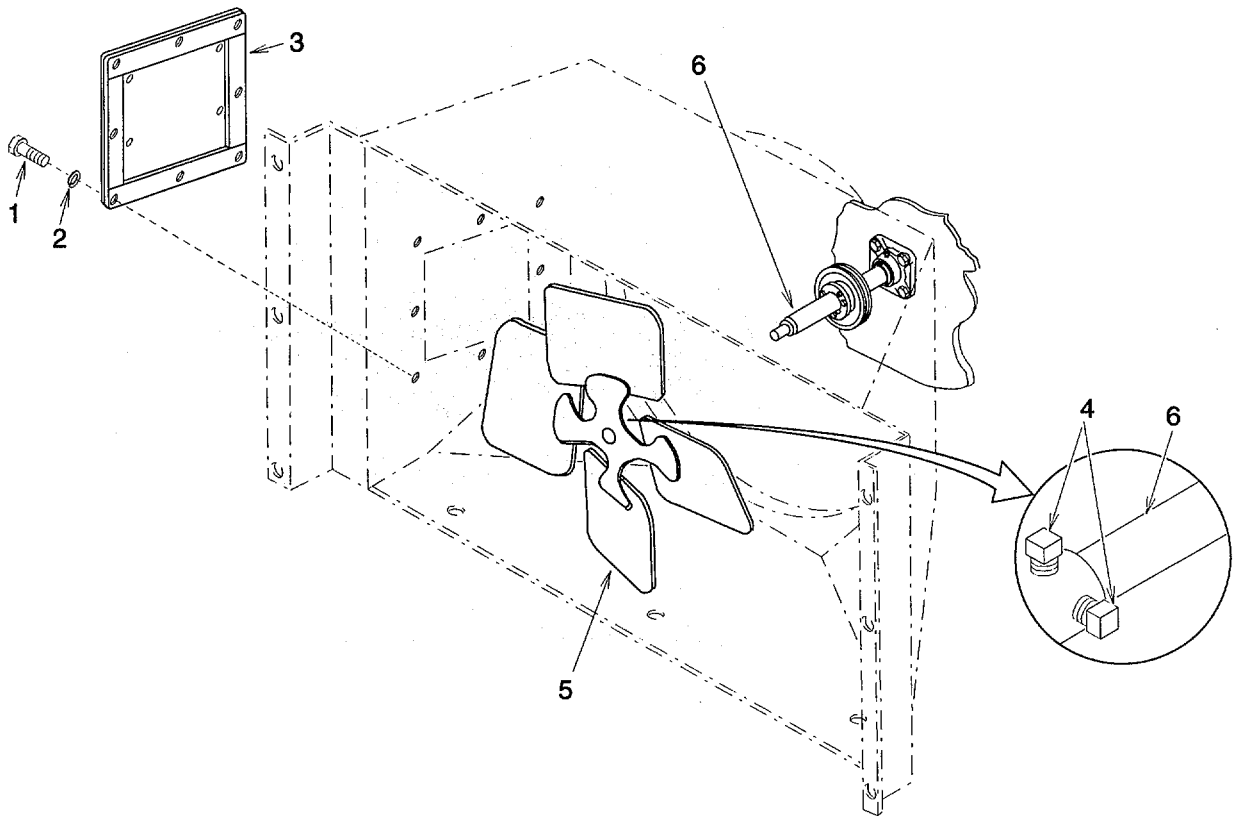

Figure 4-37. Condenser Fan

NOTE

FOLLOW-ON MAINTENANCE
Close left side door
Connect power and put unit back into service

4-43. EVAPORATOR FAN REPLACEMENT.

This task covers: a. Removal b. Installation

INITIAL SETUPEquipment Conditions:

Refrigeration unit shut down (para 2-7) and power disconnected.
Cover panel removed (para 4-16).

General Safety Instructions.**WARNING**

High voltage and exposed rotating parts are used in the refrigeration unit. Personal injury can result if power is connected.

a. Removal.

- (1) Loosen two set screws (1)
- (2) Carefully pull evaporator fan (2) off fan drive shaft (3) and remove.

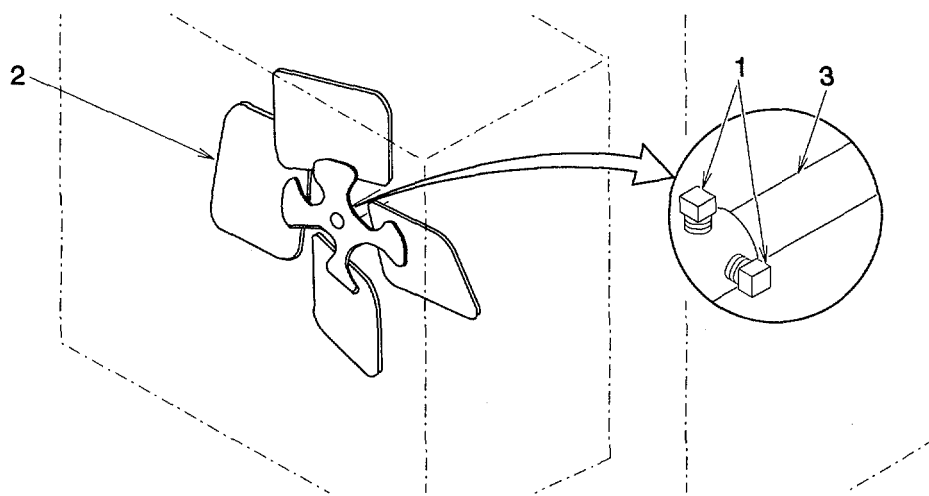

Figure 4-38. Evaporator Fan

b. Installation

- (1) Install fan (2) on fan drive shaft (3).
- (2) Tighten two set screws (1) against flat surfaces on fan drive shaft.

NOTE

FOLLOW-ON MAINTENANCE
Install cover panel (para 4-16)
Connect power and put unit back into service.

4-44. PULLEY (SHEAVE AND BUSHING) REPLACEMENT.

This task covers: a. Removal b. Installation

INITIAL SETUPEquipment Conditions.

Refrigeration unit shut down (para 2-7) and power disconnected
V-belt removed from pulley only (para 4-38).

General Safety Instructions:**WARNING**

High voltage and exposed rotating parts are used in the refrigeration unit. Personal injury can result if power is connected

a. Removal.

- (1) Remove three bolts (1) and install two bolts back into threaded holes in bushing (2) Tighten bolts evenly to separate bushing from sheave (4). Remove two bolts from bushing.
- (2) Slide bushing (2) and sheave (4) off fan drive shaft (5) being careful not to lose keys (3) and (6) Remove keys.

b. Installation.

- (1) Install key (6) than slide sheave (4) and bushing (2) onto fan drive shaft (5) Aline bushing over key.
- (2) Install key (3) then aline sheave (4) with key and slide onto bushing (2).
- (3) Install three bolts (1) and tighten evenly to secure sheave (4) to bushing (2).

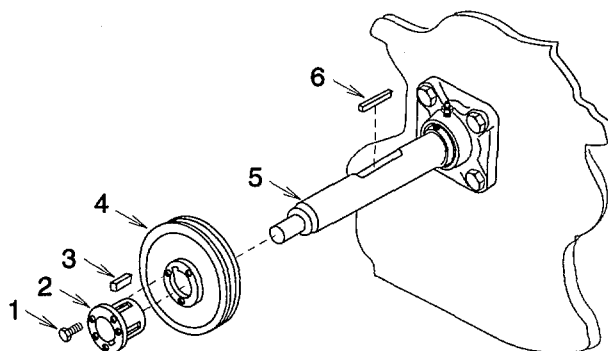

Figure 4-39. Sheave

NOTE

FOLLOW-ON MAINTENANCE
Install V-belt onto pulley and adjust (para 4-38)
Install condenser fan (para 4-42)
Connect power and put unit back into service

4-45. FLANGE BEARING (EVAPORATOR FAN) REPLACEMENT.

This task covers: a. Removal b. Installation

INITIAL SETUP

Materials/Parts-

Lock Washers (4)
16, Appendix G

General Safety Instructions:

WARNING

High voltage and exposed rotating parts are used in the refrigeration unit. Personal injury can result if power is connected

Equipment Conditions:

Refrigeration unit shut down (para 2-7) and power disconnected
Evaporator fan removed (para 4-43).

a. Removal.

- (1) Remove four bolts (1), lock washers (2). Discard lock washers
- (2) Loosen two setscrew (3) and slide flange bearing (4) off fan drive shaft (5)
- (3) Loosen grease fitting extension (6) and move out of the way.

b. Installation.

NOTE

New flange bearing will have a grease fitting that must be removed.

- (1) Install grease fitting extension (6).
- (2) Slide flange bearing (4) onto fan drive shaft (5) and align grease fitting in up position.
- (3) Install four new lock washers (2), and bolts (1).
- (4) Tighten two set screws (3).

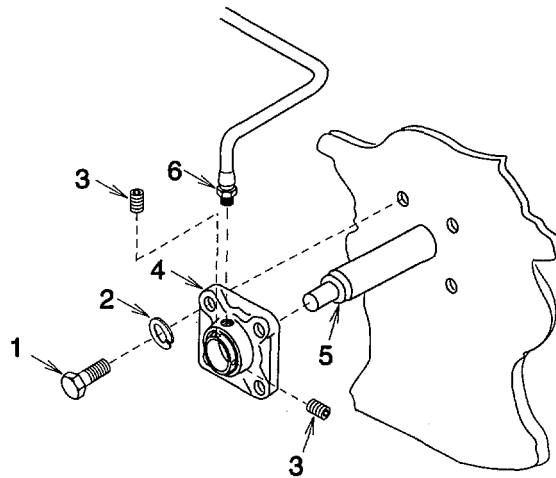

Figure 4-40. Flange Bearing (Evaporator Fan)

NOTE

FOLLOW-ON MAINTENANCE:
Install evaporator fan (para 4-43).
Connect power and put unit back into service.

4-46. FLANGE BEARING (CONDENSER FAN) REPLACEMENT

This task covers a. Removal b. Installation

INITIAL SETUPMaterials/Parts

Lock Washers (4)
16, Appendix G

Equipment Conditions

Refrigeration unit shut down (para 2-7) and power
disconnected
Pulley removed (para 4-44).

General Safety Instructions:**WARNING**

High voltage and exposed rotating parts are used in the refrigeration unit. Personal injury can result **if** power is connected.

a. Removal

- (1) Remove four bolts (1), and lock washers (2) Discard lock washers
- (2) Loosen two set screws (3)
- (3) Slide flange bearing (4) off fan drive shaft (5)

b. Installation.

- (1) Slide flange bearing (4) over fan drive shaft (5)
- (2) Install four new lock washers (2), and bolts (1)
- (3) Tighten two set screws (3)

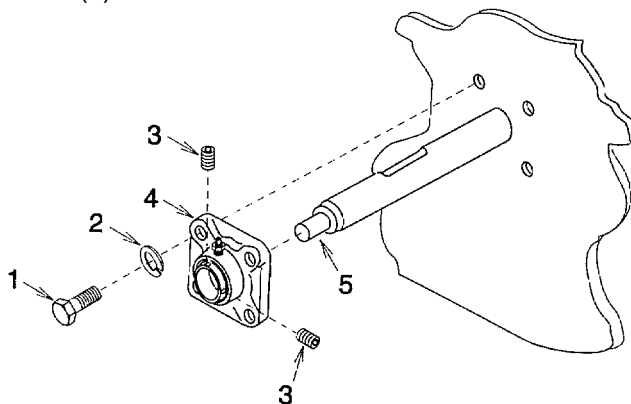

Figure 4-41. Flange Bearing (Condenser Fan)

NOTE**FOLLOW-ON MAINTENANCE**

Install pulley (para 4-44).
Connect power and put unit back into service

4-47. SOLENOID VALVE L1 (LIQUID LINE) TESTING AND REPAIR.

This task covers: a. Testing b. Removal c. Installation

INITIAL SETUPMaterials/Parts:

Marker tags (2)
7, Appendix E

General Safety Instructions:

WARNING

Equipment Conditions

Refrigeration unit shut down (para 2-7) and power disconnected.
Right side door open.
Front bottom door open

High voltage and exposed rotating parts are used in the refrigeration unit. Personal injury can result if power is connected.

a. Testing. (See Figure 1-4.)

- (1) Tag and disconnect tabs (1).
- (2) Using multimeter set to measure continuity, check coil (2) continuity between tabs (1). Continuity should be indicated. If no continuity was indicated, replace coil.
- (3) Using multimeter set to measure continuity, check coil (2) continuity between each tab (1) and coil (2) metal case. No continuity should be indicated. If continuity was indicated, replace coil.
- (4) If no failure was indicated check tabs (1) and tab housing (3). If damaged, repair or replace per paragraph 4-20.
- (5) Using tags and wiring diagram (fig. 1-4) connect tabs (1). Remove tags.

NOTE

The only authorized repair to the solenoid valve is coil replacement. The coil can be replaced without opening the refrigeration pressure system.

b. Removal.

WARNING

Do not attempt any disassembly of the solenoid valve other than coil removal with a refrigerant charge in the system. Refrigerant will be sprayed out dangerously if the screws that attach the tube and plunger assembly to the valve body are loosened.

- (1) Tag and disconnect tabs (1)

4-47. SOLENOID VALVE L1 (LIQUID LINE) TESTING AND REPAIR - Continued**NOTE**

Mounting hardware is not supplied with coil. Screw and lock washer must be retained for use during installation of coil.

- (2) Remove screw (4), lock washer (5), data plate (6), and coil (2).
- (3) Cut wire leads (7) if necessary and remove grommet (8).

c. Installation

- (1) Push wire leads (7) through grommet (8) and install grommet into coil (2).
- (2) Install two tab housings (3) and tabs (1) (para 4-20).
- (3) Install coil (2), data plate (6), lock washer (5), and screw (4).
- (4) Using tags and wiring diagram (fig 1-4) connect tabs (1). Remove tags.

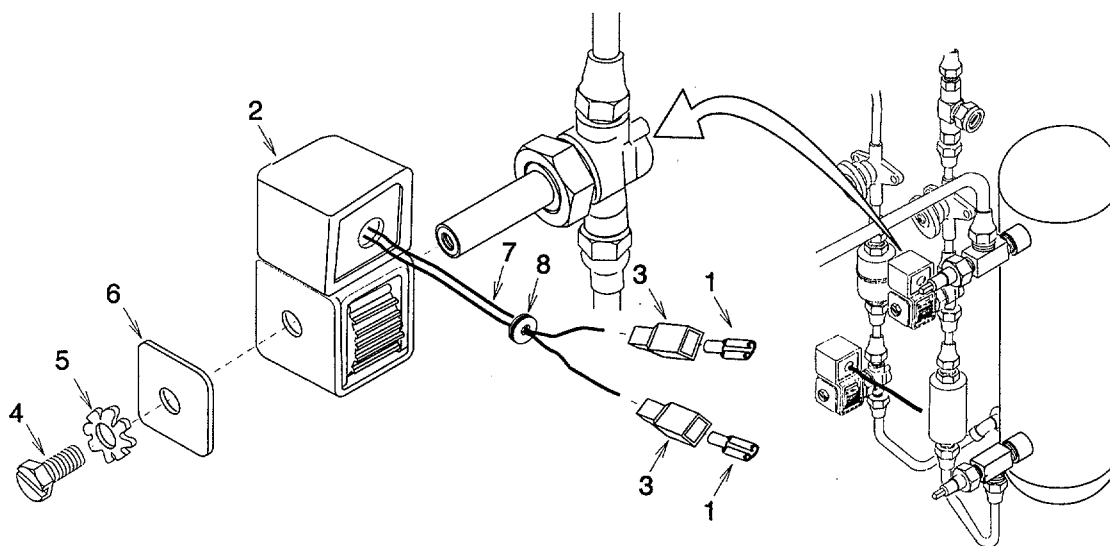

Figure 4-42. Solenoid Valve (Liquid Line)

NOTE

FOLLOW-ON MAINTENANCE:
 Close right side door
 Close front bottom door
 Connect power and put unit back into service.

4-48. SOLENOID VALVE L2 (DEFROST LINE) TESTING AND REPAIR

This task covers a. Testing b. Removal c. Installation

INITIAL SETUPMaterials/Parts

Marker tags (2)
7, Appendix E

General Safety Instructions**WARNING**

High voltage and exposed rotating parts are used in the refrigeration unit. Personal injury can result if power is connected.

Equipment Conditions

Refrigeration unit shut down (para 2-7) and power disconnected
Right side door open
Front bottom door open

a. Testing (See Figure 1-4)

- (1) Tag and disconnect tabs (1)
- (2) Using multimeter set to measure continuity, check coil (2) continuity between tabs (1). Continuity should be indicated. If no continuity was indicated, replace coil.
- (3) Using multimeter set to measure continuity, check coil (2) continuity between each tab (1) and coil (2) metal case. No continuity should be indicated. If continuity was indicated, replace coil.
- (4) If no failure was indicated, check tabs (1) and tab housing (3). If damaged, repair or replace per paragraph 4-20.
- (5) Using tags and wiring diagram (fig 1-4) connect tabs (1). Remove tags.

NOTE

The only authorized repair to the solenoid valve is coil replacement. The coil can be replaced without opening the refrigeration pressure system.

b. Removal.**WARNING**

Do not attempt any disassembly of the solenoid valve other than coil removal with a refrigerant charge in the system. Refrigerant will be sprayed out dangerously if the screws that attach the tube and plunger assembly to the valve body are loosened.

- (1) Tag and disconnect tabs (1)

4-48. SOLENOID VALVE L2 (DEFROST LINE) TESTING AND REPAIR. - Continued**NOTE**

Mounting hardware is not supplied with coil. Screw and lock washer must be retained for use during installation of coil.

- (2) Remove screw (4), lock washer (5), data plate (6), and coil (2).
- (3) Cut wire leads (7) if necessary and remove grommet (8).

c. Installation.

- (1) Push wire leads (7) through grommet (8) and install grommet into coil (2).
- (2) Install two tab housings (3) and tabs (1) (para 4-20).
- (3) Install coil (2), data plate (6), lock washer (5), and screw (4).
- (4) Using tags and wiring diagram (fig. 1-4) connect tabs (1). Remove tags

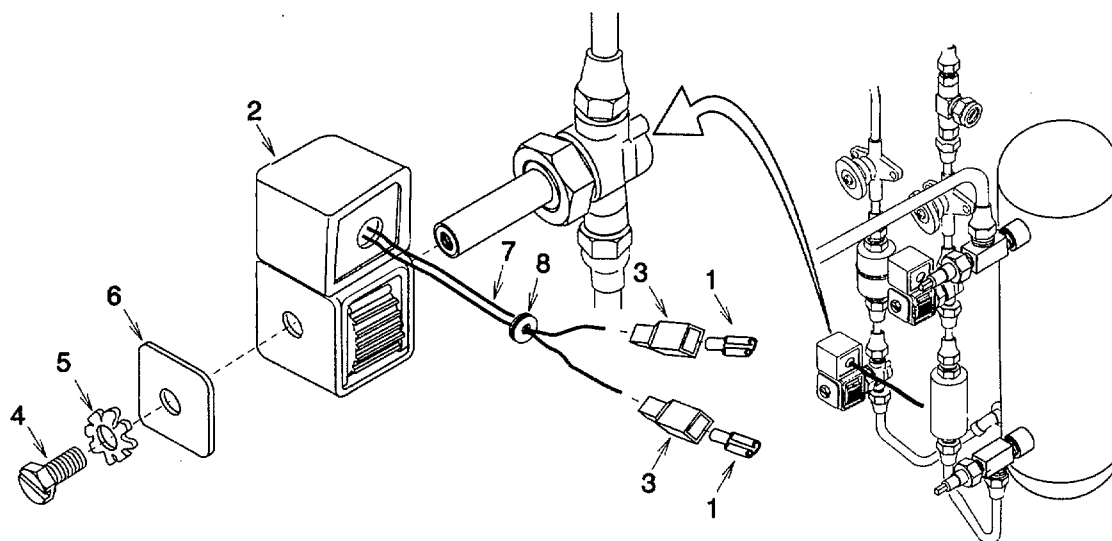

Figure 4-43. Solenoid Valve L2 (Defrost Line)

NOTE

FOLLOW-ON MAINTENANCE.
 Close right side door.
 Close front bottom door
 Connect power and put unit back into service.

4-49. THERMOMETER TESTING AND REPLACEMENT

This task covers: a. Testing b. Removal c. Installation

INITIAL SETUPMaterials/Parts:

Self Locking Nut
12, Appendix G
Self Locking Nuts (3)
8, Appendix G
Tie Down Straps
24, Appendix E
Silicone RTV
20, Appendix E
Lock Washers (3)
1, Appendix G

Equipment Conditions

Refrigeration unit shut down (para 2-7) and power disconnected
Control box cover door raised and latched
Right side door open
Cover panel removed (para 4-16).

General Safety Instructions**WARNING**

High voltage and exposed rotating parts are used in the refrigeration unit. Personal injury can result if power is connected.

a. Testing

- (1) Be sure power has been disconnected at the source and remove two bolts (1), lock washers (2), flat washers (3) and sensing bulb bracket (4). Discard lock washers
- (2) Remove self locking nut (5), lock washer (6), bolt (7), and sensing bulb bracket (4) Discard self locking nut and lock washer.
- (3) Remove clamp (8)
- (4) Immerse sensing bulb (9) into a temperature controlled bath at 320 F (0° C) A bath at this temperature can be made by putting the sensing bulb into a container of ice and covering with water Ice must remain packed around sensing bulb at all times during test
- (5) Check temperature indicated on thermometer (10) Temperature indicated should be between 24° F (-4° C) and 40° F (4° C) If temperature indicated is above or below this range, replace thermometer
- (6) If no failure was indicated, slip clamp (8) over sensing bulb (9).
- (7) Install clamps (8) and (11), bolt (7), new lock washer (6) and new self locking nut (5).
- (8) Install sensing bulb bracket (4), two flat washers (3), new lock washers (2), and bolts (1)

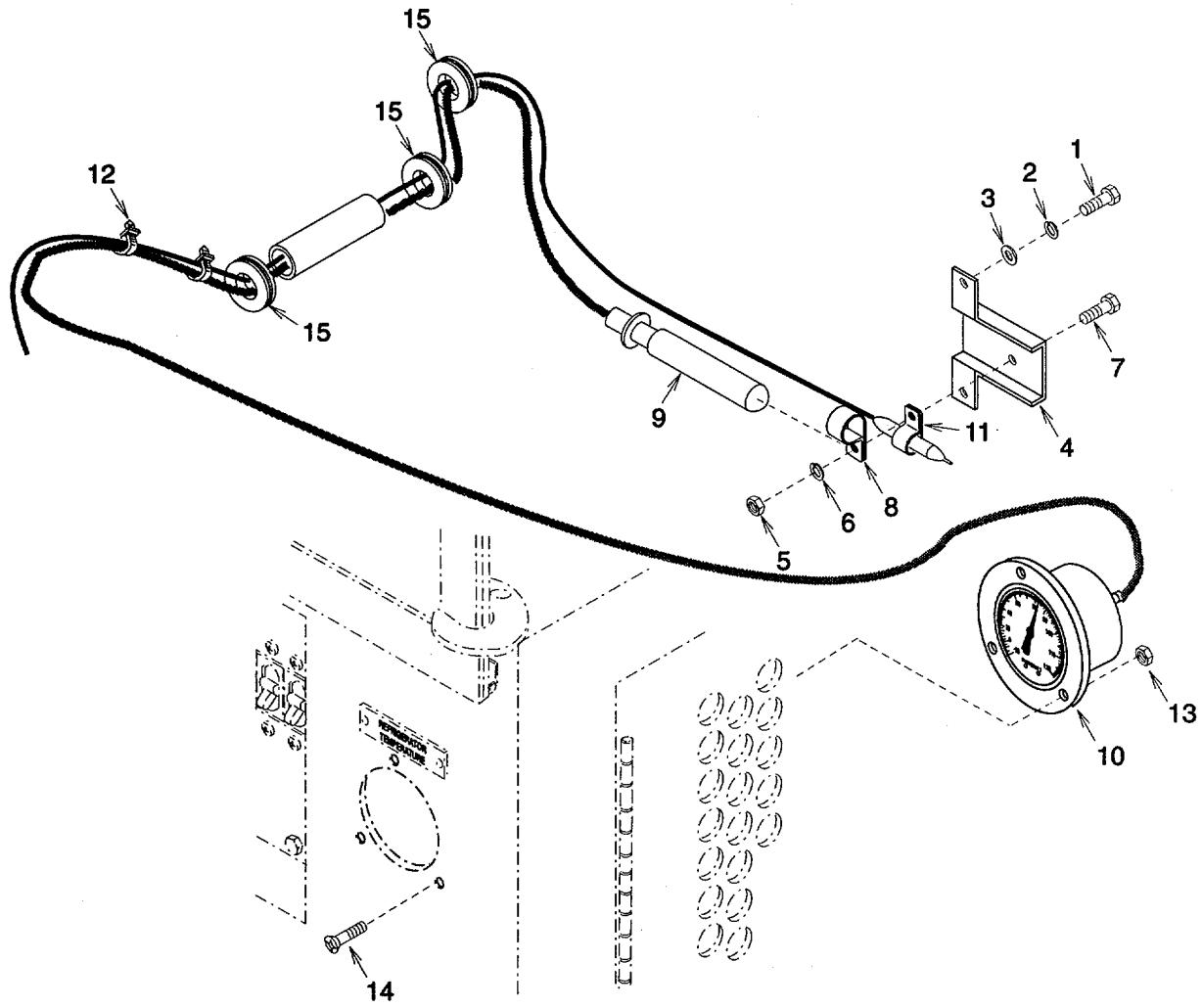

Figure 4-44. Refrigeration Temperature Gage (Thermometer)

b. Removal.

- (1) Be sure power has been disconnected at the source and remove two bolts (1), lock washers (2), flat washers (3), and sensing bulb bracket (4). Discard lock washers.
- (2) Remove self locking nut (5), lock washer (6), bolt (7), and sensing bulb bracket (4). Discard self locking nut and lock washer
- (3) Remove clamp (8) from sensing bulb (9)
- (4) Remove tiedown straps (12).
- (5) Remove three self locking nuts (13), and screws (14). Discard self locking nuts.
- (6) Remove thermometer (10), and any grommets (15) necessary to remove sensing bulb (9)
- (7) Remove any silicone RTV remaining in grommets (15)

c. Installation.

- (1) Install thermometer (10) routing sensing bulb (9) through grommets (15). Install any grommets removed
- (2) Install thermometer (10), three screws (14), and new self locking nuts (13).
- (3) Install tie down straps (12) as necessary.
- (4) Slip clamp (8) over sensing bulb (9).
- (5) Install clamps (8) and (11), bolt (7), new lock washer (6), and new self locking nut (5)
- (6) Install sensing bulb bracket (4), two flat washers (3), new lock washers (2), and bolts (1)
- (7) Apply silicone RTV into grommets (15) to seal evaporator enclosure.

NOTE

FOLLOW-ON MAINTENANCE
 Unlatch and close control box cover door.
 Close right side door.
 Install cover panel (para 4-16)
 Connect power and put unit back into service

4-50. GREASE FITTING EXTENSION REPLACEMENT.

This task covers: a. Removal b. Installation

INITIAL SETUP

Materials/Parts:

Self Locking Nuts (2)
12, Appendix G

Equipment Conditions

Refrigeration unit shut down (para 2-7) and power disconnected.

General Safety Instructions.

WARNING

High voltage and exposed rotating parts are used in the refrigeration unit. Personal injury can result if power is connected.

a. Removal.

NOTE

Grease fitting is not supplied with grease fitting extension

- (1) Remove grease fitting (1).
- (2) Remove two self locking nuts (2), bolts (3), flat washers (4), clamps (5) and one spacer (6). Discard self locking nuts.
- (3) Remove grease fitting extension (7) and two grommets (8).

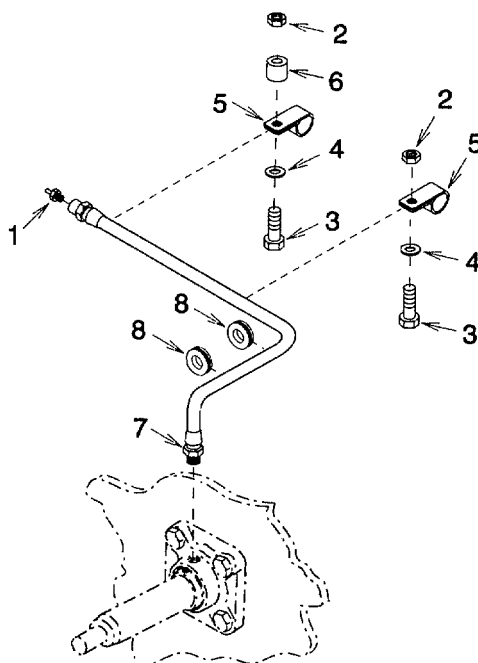

Figure 4-45. Grease Fitting Extension
4-106

b. Installation.

- (1) Install grease fitting (1)
- (2) Install grease fitting extension (7), and route through enclosure opening.
- (3) Install two grommets (8)
- (4) Install two clamps (5), bolts (3), flat washers (4), one spacer (6), and two new self locking nuts.

NOTE

FOLLOW-ON MAINTENANCE.
Close right side door.
Connect power and put unit back into service.

4-51. DEFROST TERMINATION THERMOSTAT S4 TESTING AND REPLACEMENT

This task covers: a. Removal b. Installation

INITIAL SETUP

Materials/Parts

Tie down Straps (2)

25, Appendix E

Marker tags (2)

7, Appendix E

Insulation Tape

10, Appendix E

General Safety Instructions:

WARNING

High voltage and exposed rotating parts are used in the refrigeration unit. Personal injury can result if power is connected.

Equipment Conditions.

Refrigeration unit shut down (para 2-7) and power disconnected

Access panel removed (para 4-15)

a. Removal.

- (1) Remove insulation (1) as necessary.
- (2) Be sure power has been disconnected at the source then tag and disconnect two tabs (2).
- (3) Remove two tiedown straps (3) and defrost temperature switch (4).

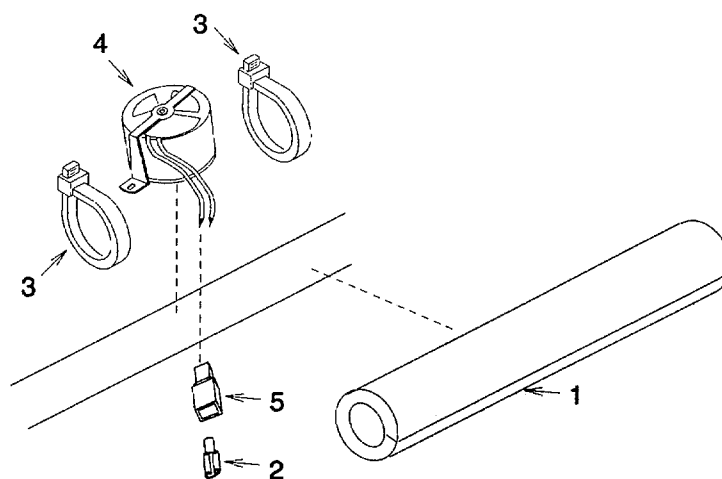

Figure 4-46. Defrost Temperature Switch

b. Installation

- (1) Install defrost temperature switch (4), and secure using two tiedown straps (3)
- (2) Install two new tab housings (5) and tabs (2) onto each defrost temperature switch (4) wire lead per paragraph 4-20.
- (3) Using tags and wiring diagram (fig. 1-4), connect tabs (2). Remove tags
- (4) Install insulation (1) with insulation tape as necessary.

NOTE

FOLLOW-ON MAINTENANCE:
Install access panel (para 4-15).
Connect power and put unit back into service.

4-52. GROUND STRAP (COMPRESSOR) REPLACEMENT.

This task covers: a. Removal b. Installation

INITIAL SETUPMaterials/Parts:

Lock Washers
1, Appendix G
Self Locking Nut

Equipment Conditions:

Refrigeration unit shut down (para 2-7) and power disconnected.

General Safety Instructions**WARNING**

High voltage and exposed rotating parts are used in the refrigeration unit. Personal injury can result if power is connected.

- a. Removal. Be sure power has been disconnected at the source and remove self locking nut (1), flat washer (2), bolt (3), lock washer (4), and ground strap (5). Discard lock washer and self locking nut
- b. Installation Install ground strap (5), new lock washer (4), screw (3), flat washer (2), and new self locking nut (1).

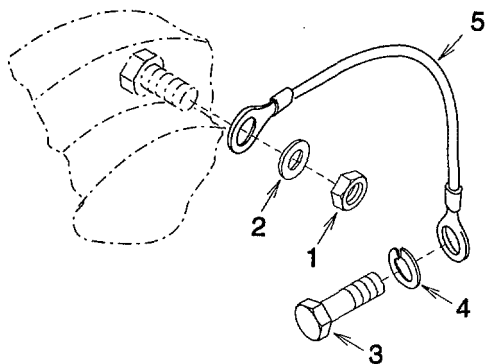

Figure 4-47. Ground Strap (Compressor)

NOTE

FOLLOW-ON MAINTENANCE
Connect power and put unit back into service.

4-53. HEAT SHIELD GASKETS REPLACEMENT

This task covers: a. Removal b. Installation

INITIAL SETUP

Materials/Parts:

Silicone RTV

20, Appendix E

Gaskets (2)

Figure F-7, Appendix F

Gaskets (2)

Figure F-8, Appendix F

General Safety Instructions

WARNING

High voltage and exposed rotating parts are used in the refrigeration unit. Personal injury can result if power is connected.

Equipment Conditions

Refrigeration unit shut down (para 2-7) and power disconnected

a. Removal.

- (1) Remove eight screws (1), two gasket retainer strips (2), and top gasket (3). Repeat for bottom gasket.
- (2) Remove eight screws (4), two gasket retainer strip (5), and left side gasket (6). Repeat for right side gasket.

b. Installation.

- (1) Coat the cut surfaces of two each gaskets (3) and (6) with silicone RTV to seal foam.
- (2) Install right side gasket (6), two gasket retainer strips (5), and eight screws (4). Repeat for right side.
- (3) Install top gasket (3), two retainer strips (2), and eight screws (1). Repeat for bottom gasket.
- (4) Seal four seams (7) with silicone RTV.

4-53. HEAT SHIELD GASKETS REPLACEMENT - Continued

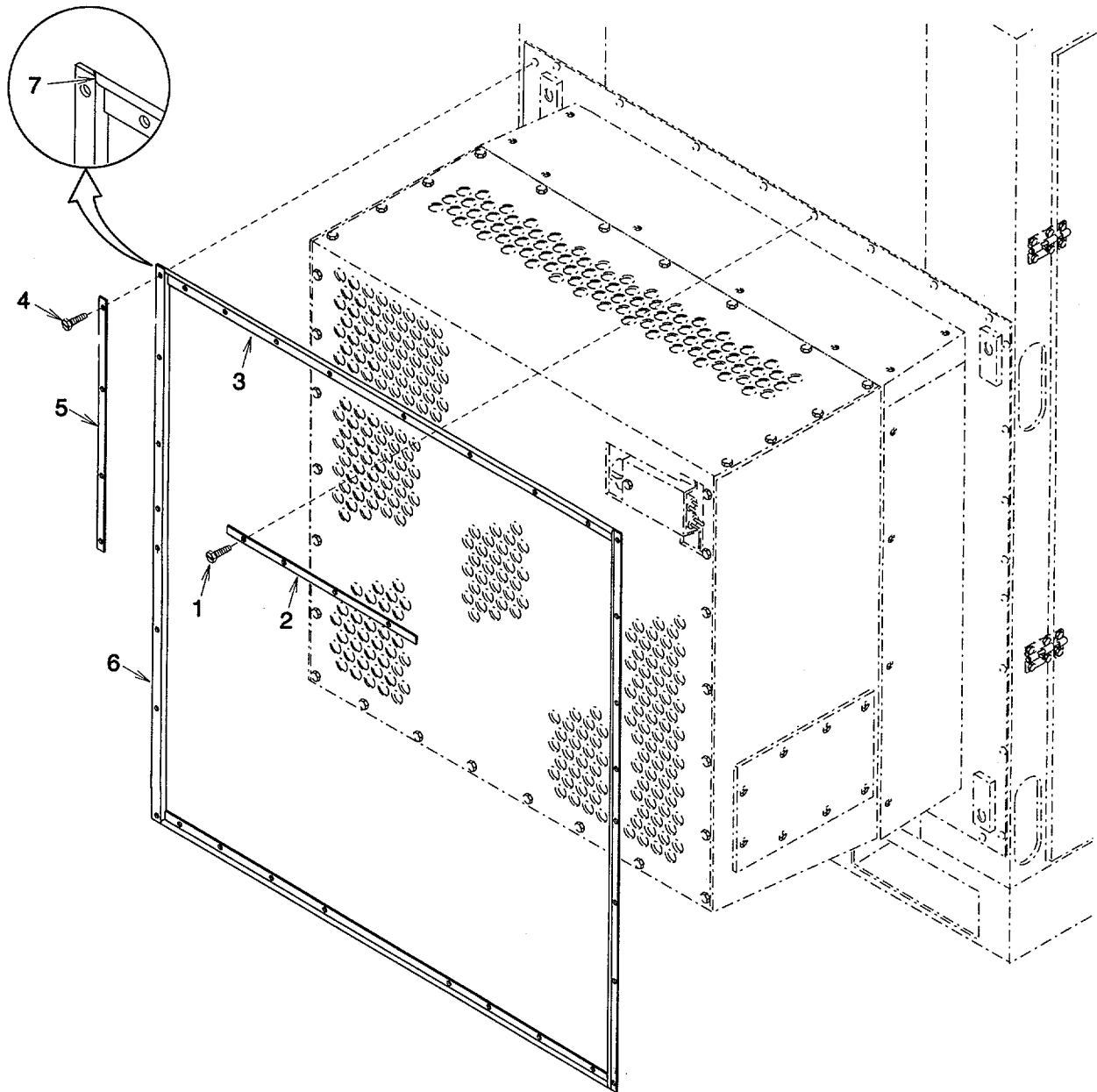

Figure 4-48. Heat Shield Gaskets

NOTE

FOLLOW-ON MAINTENANCE.
Connect power and put unit back into service.

SECTION VI PREPARATION FOR STORAGE OR SHIPMENT

4-54. ADMINISTRATIVE STORAGE

Placement of equipment in administrative storage should be for short periods of time (1 to 45 days) when a shortage of maintenance effort exists. Items should be in mission readiness within 24 hours or within the time factors determined by the directing authority. During the storage period, appropriate maintenance records will be kept.

a. Before placing the equipment in administrative storage, current preventive maintenance checks and services should be completed, shortcomings and deficiencies should be corrected, and all Modification Work Orders (MWO) should be applied.

b. Storage site selection. Inside storage is preferred for items selected for administrative storage. If inside storage is not available, trucks, vans, Conex containers, and other containers may be used.

4-55. PUMP DOWN REFRIGERATION UNIT

WARNING

High voltage and exposed rotating parts are contained in the refrigeration unit. Personal injury can result if power is connected.

NOTE

Refrigeration unit should be pumped down if out of service for longer than 5 days.

- a. Be sure refrigeration unit is shut down and power is disconnected then remove two isolation valve caps (1) and shut off valve caps (2)
- b. Close hot gas stop valve (3).
- c. Close receiver outlet valve (4).
- d. Be sure the side doors are closed and operate the refrigeration unit (para 2-5) until it shuts down automatically
- e. Shut down the refrigeration unit (para 2-7) and disconnect power
- f. Close receiver inlet valve (5), compressor shut off valves (6), and liquid stop valve (7).
- g. Install two shut off valve caps (2) and isolation valve caps (1)
- h. Place marker (7, appendix E) on or near the control box cover stating "THE REFRIGERATION UNIT HAS BEEN PUMPED DOWN, DO NOT OPERATE UNTIL ALL VALVES HAVE BEEN PROPERLY SET, EQUIPMENT DAMAGE WILL OCCUR"

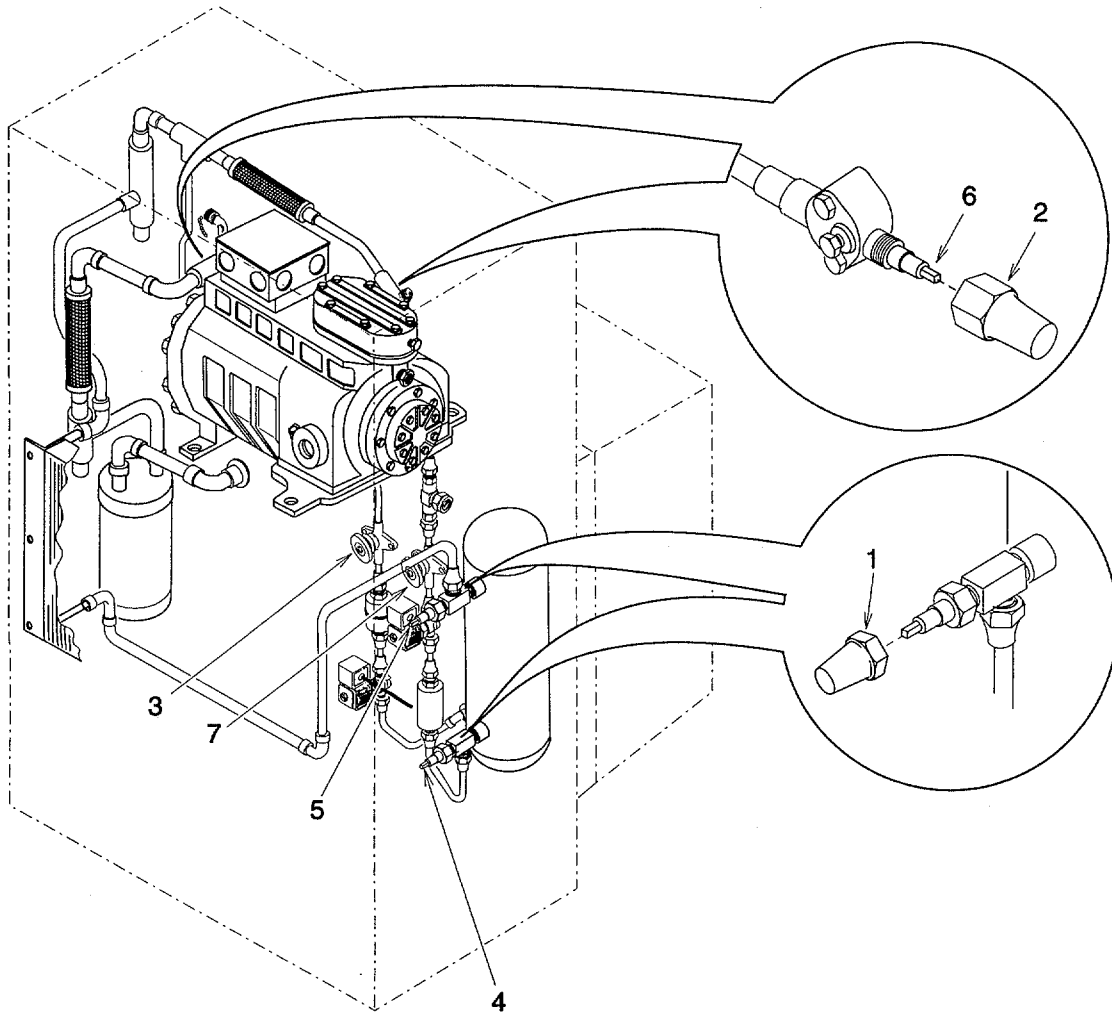

Figure 4-49. Refrigeration System Pump Down

4-56. LONG TERM STORAGE OR SHIPMENT.

Placement of equipment in long term storage should be for extended periods of time (45 days or more). Before placing the equipment in long term storage, current preventive maintenance checks and services should be completed, shortcomings and deficiencies should be corrected, and all Modification Work Orders (MWO) should be applied.

- a. Open both side doors and front bottom door.
- b. Tighten four compressor mount lock nuts (1, fig. 4-50) just to the point where shipping brackets (2) cannot be removed from springs (3).

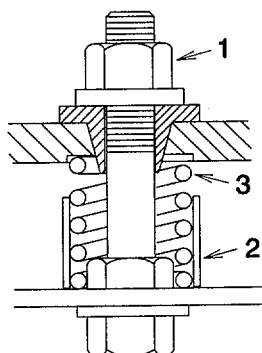

Figure 4-50. Compressor Mount

- c. Close both side doors and front bottom door

NOTE

Refrigerant and oil will not be removed from the system

- d. Preserve the refrigeration unit in accordance with MIL-P-116, method I.
 - (1) Cover all openings into the electric motor, evaporator panel, glass gages, name plates and instruction panels, switches, control box, etc., with waterproof paper and seal with tape conforming to PPP-T-60 (1, Appendix E), or with a barrier material conforming to grade A of PP-C-843 (2, Appendix E) and secured in place.
 - (2) Package the refrigeration unit in accordance with ASTM D 3951, level or Commercial.
 - (3) Refrigeration unit shall be packed upright in an open crate or cleated plywood box conforming to type V, style A or MIL-C-52950 or style B for overseas. Each unit shall be secured and the container closed and strapped with 3/4 inch by 0.23 inch steel. The strappings shall be applied over the horizontal top, bottom, and intermediate cleats of the side and ends.
 - (4) Shipping containers shall be marked with the words "UP" and "THIS SIDE DOWN" shall appear on each shipping container.

CHAPTER 5

DIRECT SUPPORT MAINTENANCE INSTRUCTIONS

SECTION I DIRECT SUPPORT TROUBLESHOOTING INSTRUCTIONS

5-1. TROUBLESHOOTING.

The following procedures are listed in order of the most probable malfunctions. Each malfunction is followed by test or inspection procedures in logical order to isolate and identify the fault and actions required to correct it. This section cannot list all the possible malfunctions that may occur with the equipment. If a malfunction occurs that is not listed or actions listed do not correct a malfunction, notify your supervisor

a. Pressure Gage (Discharge) Indicates Above Operating Range.

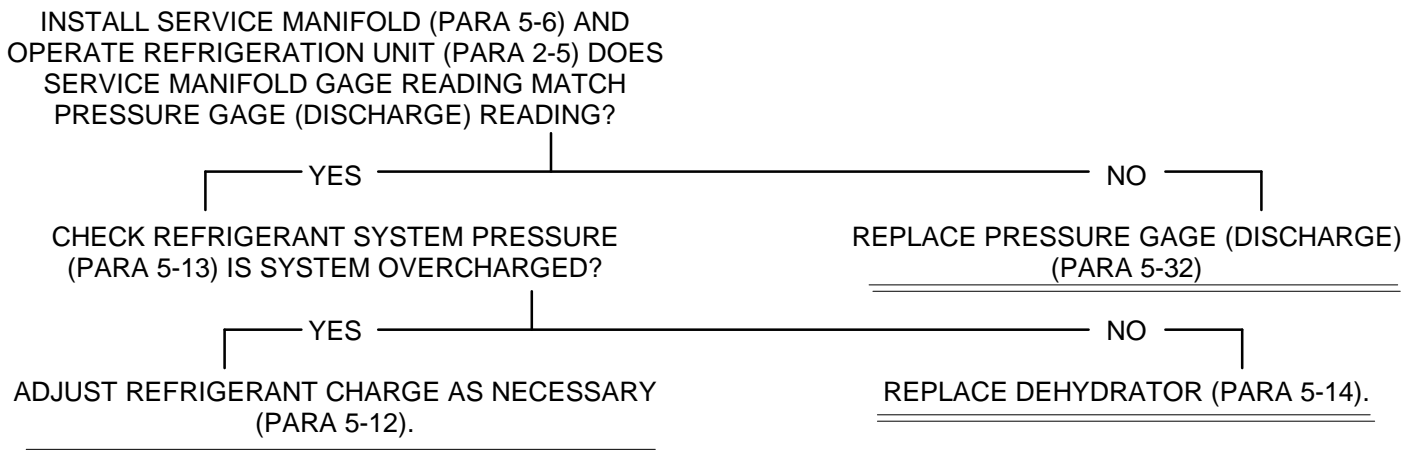

b. Compressor Operates For Short Period Then Stops.

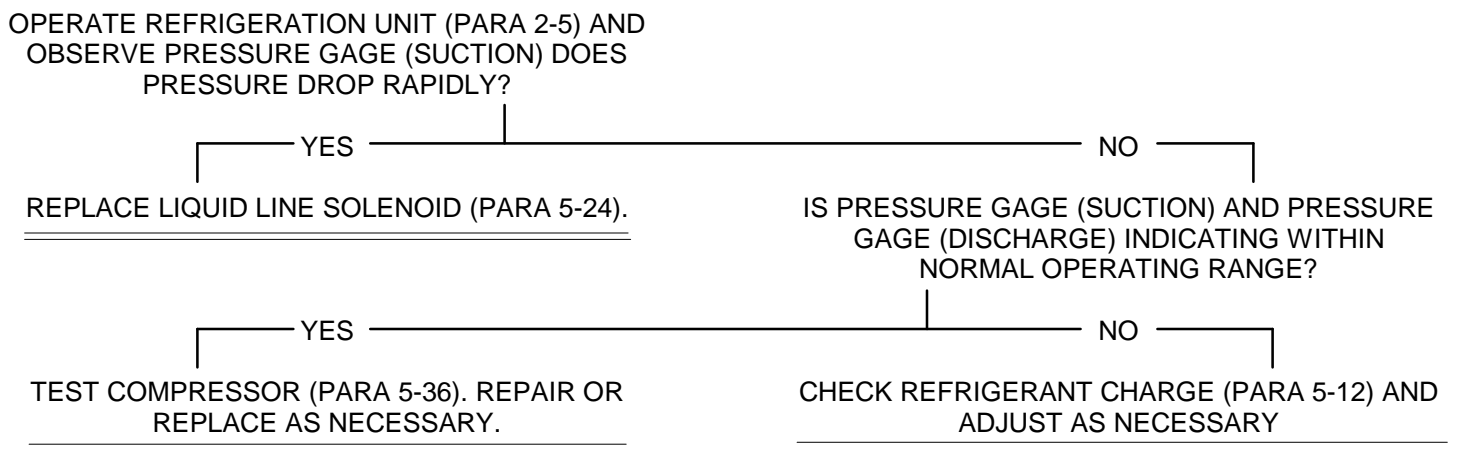

5-1. TROUBLESHOOTING. - Continued

c. Pressure Readings Low/Insufficient Cooling.

SHUT DOWN REFRIGERATION UNIT (PARA 2-7)
DOES THE REFRIGERATION UNIT STOP RUNNING?

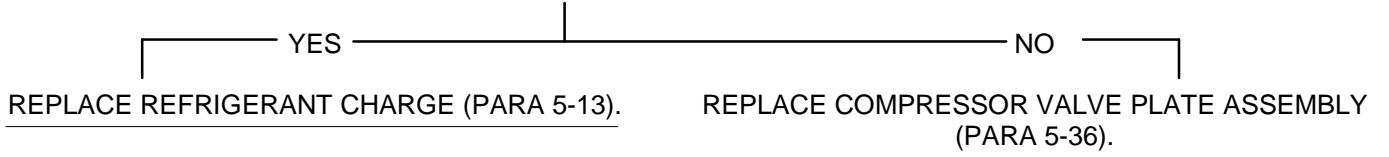

SECTION II DIRECT SUPPORT MAINTENANCE PROCEDURES**5-2. CIRCUIT BREAKER COVER REPAIR.**

This task covers: Repair

INITIAL SETUP**Materials/Parts**

Adhesive, General Purpose

14, Appendix E

Wiping Rag

3, Appendix E

Acetone

18, Appendix E

Methyl-Ethyl Keton

19, Appendix E

Gaskets (2)

6, Figure F-5, Appendix F

Gaskets (2)

Figure F-29, Appendix F

Equipment Conditions:

Circuit breaker cover removed (para 4-21).

General Safety Instructions.**WARNING**

Acetone and methyl-ethyl ketone (MEK) are flammable and their vapors can be explosive. Repeated or prolonged skin contact or inhalation of vapors can be toxic. Use in a well ventilated area, wear gloves, and keep away from sparks or flame.

Repair

- (1) Remove as much old gasket material (1) or (2) as possible by pulling or scraping it away from the circuit breaker cover (3)
- (2) Soften and remove old adhesive and gasket (1) or (2) residue, using acetone or methyl-ethyl ketone (MEK) and a stiff brush.
- (3) Be sure that the attaching surface of the circuit breaker cover (3) is clean and free of paint and old adhesive material
- (4) Coat the mating surfaces of the circuit breaker cover (3) and gasket (1) or (2) with adhesive. Let both surfaces air dry until adhesive is tacky, but will not stick to fingers
- (5) Starting with an end, carefully press gasket (1) or (2) onto the circuit breaker cover (3) Press firmly overall to ensure complete contact

5-2. CIRCUIT BREAKER COVER REPAIR. - Continued

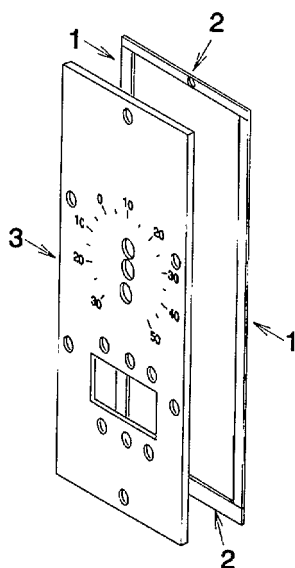

Figure 5-1. Circuit Breaker Cover

NOTE

FOLLOW-ON MAINTENANCE:
Install circuit breaker cover (para 4-21).

5-3. CONTROL PANEL REPAIR.

This task covers: Repair

INITIAL SETUP

Materials/Parts.

Lock Washers (2)
1, Appendix G
Adhesive, General Purpose
14, Appendix E
Wiping Rag
3, Appendix E
Acetone
18, Appendix E
Methyl- Ethyl Ketone
19, Appendix E
Gaskets (2)
5, Figure F-5, Appendix F
Gasket
Figure F-16, Appendix F

Equipment Conditions:

Control box cover door raised and latched.

General Safety Instructions:

WARNING

Acetone and methyl-ethyl ketone (MEK) are flammable and their vapors can be explosive. Repeated or prolonged skin contact or inhalation of vapors can be toxic. Use in a well ventilated area, wear gloves, and keep away from sparks or flame.

Repair

- (1) Remove two bolts (1) and lock washers (2). Open control panel (3). Discard lock washers.
- (2) Remove as much old gasket material (4) or (5) as possible by pulling or scraping it away from the control panel and operating instruction plate (3).
- (3) Soften and remove old adhesive and gasket (4) or (5), residue, using acetone or methyl-ethyl ketone (MEK) and a stiff brush
- (4) Be sure that the attaching surface of the control panel (3) is clean and free of paint and old adhesive material.
- (5) Coat the mating surfaces of the control panel (3) and gasket (4) or (5) with adhesive. Let both surfaces air dry until adhesive is tacky, but will not stick to fingers
- (6) Starting with an end, carefully press gasket (4) or (5) onto the control panel (3). Press firmly overall to ensure complete contact.
- (7) Close control panel (3). Install two new lock washers (2) and bolts (1)

5-3. CONTROL PANEL AND OPERATING INSTRUCTION PLATE REPAIR - Continued

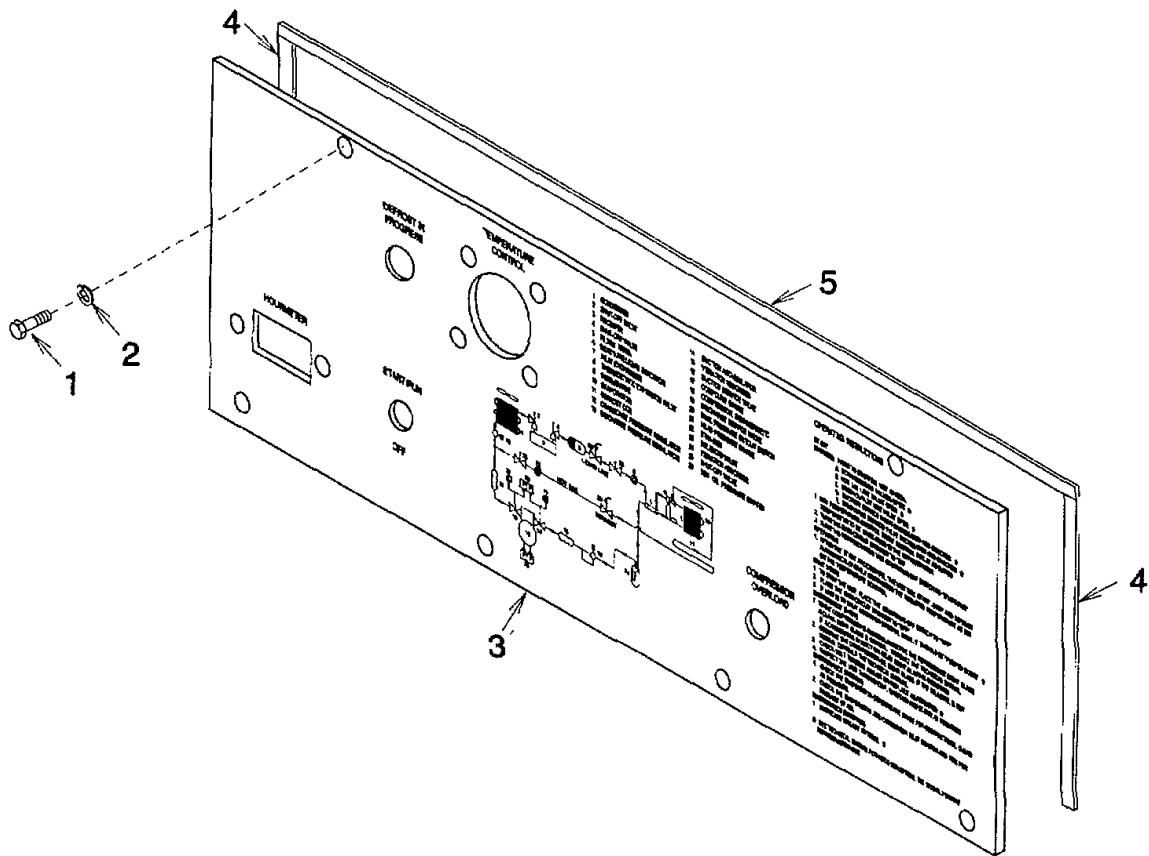

Figure 5-2. Control Panel and Operating Instruction Plate

NOTE

FOLLOW-ON MAINTENANCE
Unlatch and close control box cover door

5-4. FAN DRIVE SHAFT REPLACEMENT.

This task covers: a. Removal b. Installation

INITIAL SETUP

Equipment Conditions-

Evaporator fan removed (para 4-43).

Pulley removed (para 4-44).

Condenser coil removed (para 5-18)

General Safety Instructions:

WARNING

High voltage and exposed rotating parts are used in the refrigeration unit. Personal injury can result if power is connected.

a. Removal.

- (1) Loosen two setscrews (1) from each flange bearing (2).
- (2) Remove fan drive shaft (3).

b. Installation.

- (1) Install fan drive shaft (3).
- (2) Tighten two setscrews (1) on each flange bearing (2).

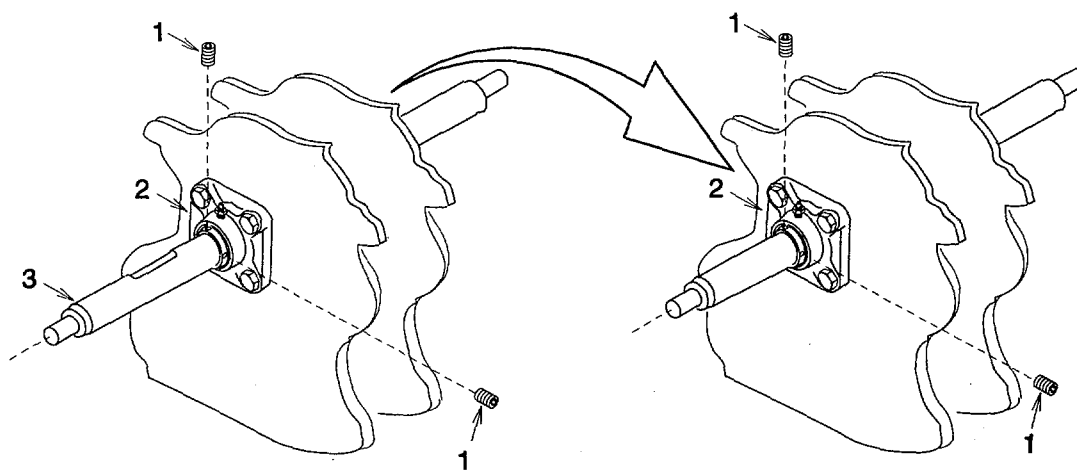

Figure 5-3. Fan Drive Shaft

NOTE

FOLLOW-ON MAINTENANCE-

- Install pulley (para 4-44).
- Install condenser fan (para 4-42).
- Install evaporator fan (para 4-43).
- Install condenser coil (para 5-18).

5-5. REFRIGERATION SYSTEM REPAIRS.

The refrigeration system must be totally discharged (para 5-7) before any maintenance is performed on system components Leak testing (para 5-10) and dehydrator replacement (para 5-14) are required after any system component has been removed and replaced The system must be properly evacuated (para 5-11) and charged (para 5-12) to function correctly

5-6. SERVICE MANIFOLD INSTALLATION.

This task covers: a. Installation b. Removal

INITIAL SETUP

Tools:

- Refrigeration Unit Service Tool Kit
4, Section III, Appendix B
- Refrigerant Recovery and Recycle Unit
5, Section III, Appendix B

Equipment Conditions

- Refrigeration shut down para 2-7) and power *
- Refrigeration unit shut down (para 2-7)
disconnected.
- Front top door open
- Both side doors open

General Safety Instructions

WARNING

- High voltage and rotating parts are used in the refrigeration unit Personal injury can result if power is connected
- Sudden and irreversible tissue damage and can result from freezing Wear gloves and can result from freezing Wear gloves and face protector or safety glasses in any situation where skin or eye contact with refrigerant is possible
- Compressor lubricating oil used in this refrigeration system is caustic Wear gloves and a face protector or safety glasses in any situation where skin or eye contact is possible If oil does contact skin, wash with soap and water
- Dangerous chemical refrigerant under pressure is used in the operation of this equipment. Use great care to avoid contact with liquid refrigerant Work in a well ventilated area.
- Heat may cause the refrigerant to decompose and release irritating, toxic, and corrosive gases Prevent contact of refrigerant with flame or hot surfaces.

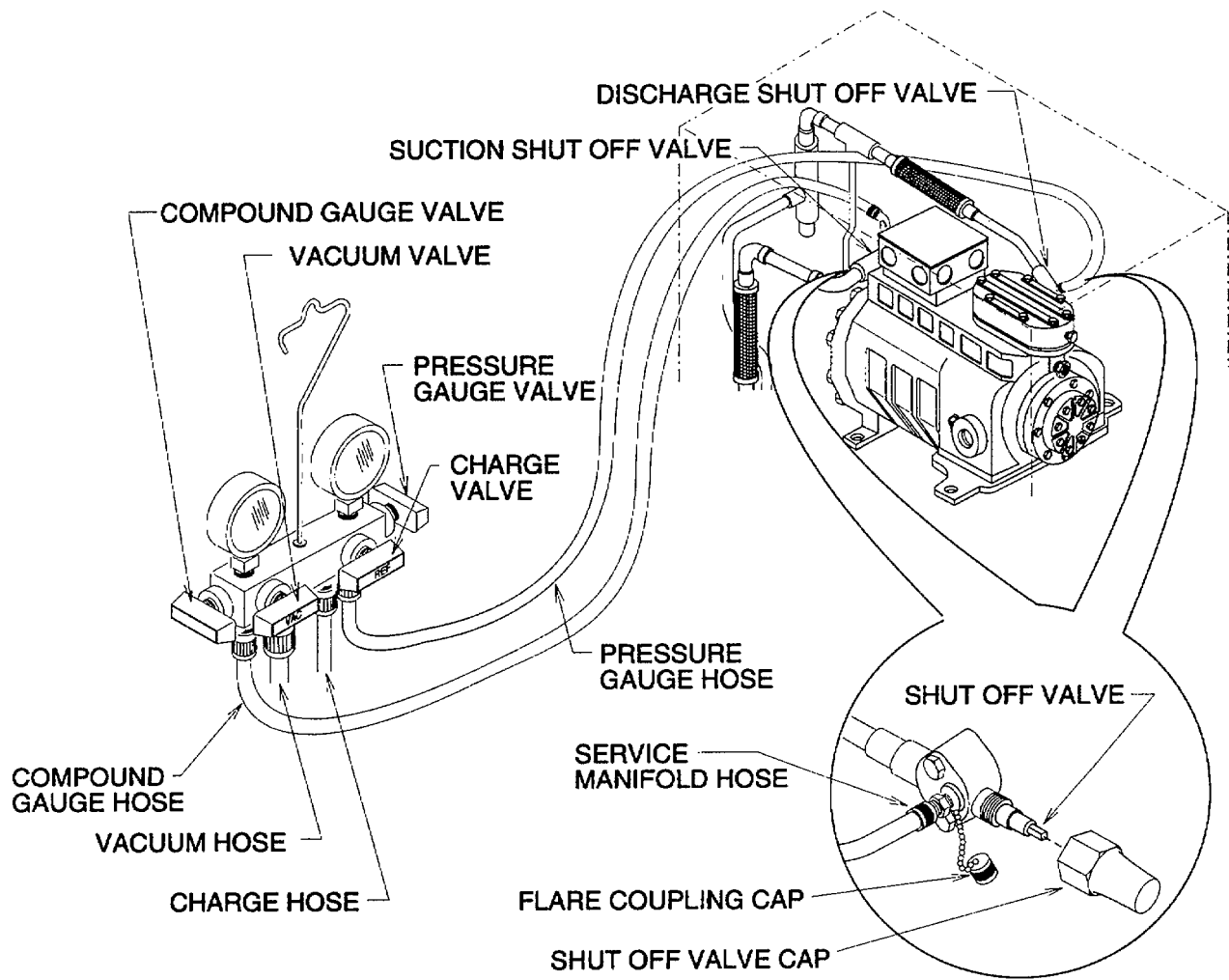

Figure 5-4. Service Manifold Installation

5-6. SERVICE MANIFOLD INSTALLATION. - Continued

a. Installation.

CAUTION

Using excessive force when opening or closing valves can cause damage to the valve seats.

NOTE

The compressor shut off valves can be adjusted to three positions, fully closed to block the refrigerant tubes and isolate the compressor and service port, fully open to allow flow from piping to compressor but not the service port, and cracked (one turn closed from fully open) to allow flow from piping to compressor and service port on valve

- (1) Remove two shut off valve caps and turn the shut off valves fully counterclockwise to backseat them.
- (2) Remove two flare coupling caps.
- (3) Check that all four service manifold valves are closed

NOTE

Push switch in side door will prevent refrigeration unit from operating if door is open. Do not pass the service manifold hoses through the side door if the refrigeration unit will need to be operated.

- (4) Pass service manifold hoses through front top door and connect service manifold pressure gauge hose to discharge flare coupling and compound gauge hose to suction flare coupling.
- (5) Connect service manifold charge hose to recovery unit.
- (6) Turn discharge and suction shut off valves one turn clockwise to crack open valves.
- (7) Open service manifold pressure gauge valve and charge valve. Operate recovery unit and allow refrigerant to purge for 3-5 seconds Close pressure gauge and charge valves then shut down recovery unit.
- (8) Open service manifold compound gauge valve and charge valve. Operate recovery unit and allow refrigerant to purge for 3-5 seconds Close compound gauge and charge valves then shut down recovery unit.

b. Removal.

- (1) Turn shut off valves fully counterclockwise to backseat them.
- (2) Open service manifold pressure and compound gauge valves.
- (3) Open service manifold charge valve. Operate recovery limit and allow refrigerant to purge from hoses.
- (4) Close service manifold valves.
- (5) Shut down recovery unit.
- (6) Disconnect service manifold pressure gauge hose from discharge flare coupling and compound gauge hose from suction flare coupling.
- (7) Install two shut off valve and flare coupling caps.

NOTE

FOLLOW-ON MAINTENANCE:

- Close front top doors.
- Close both side doors.

5-7. DISCHARGING THE REFRIGERANT SYSTEM.

This task covers: Discharge

INITIAL SETUP

Equipment Conditions:

Service manifold installed (para 5-6)

Discharge.

- (1) Check that the refrigerant system has not been pumped down (para 4-46). If it has, open necessary valves (para 4-8) to allow discharge of all refrigerant.

CAUTION

Follow instructions for specific refrigerant recovery unit being used to avoid compressor oil loss. Loss of oil could result in compressor damage.

NOTE

Venting tetrafluoroethane refrigerant into the atmosphere rather than recovering it is subject to pending EPA restrictions. Venting the refrigerant may be a violation of public law and subject to severe penalties.

- (2) Open service manifold pressure and compound gauge valves.
- (3) Open service manifold charge valve. Operate recovery unit until all refrigerant has been removed from system.
- (4) Close service manifold valves.
- (5) Shut-down refrigerant recovery unit.

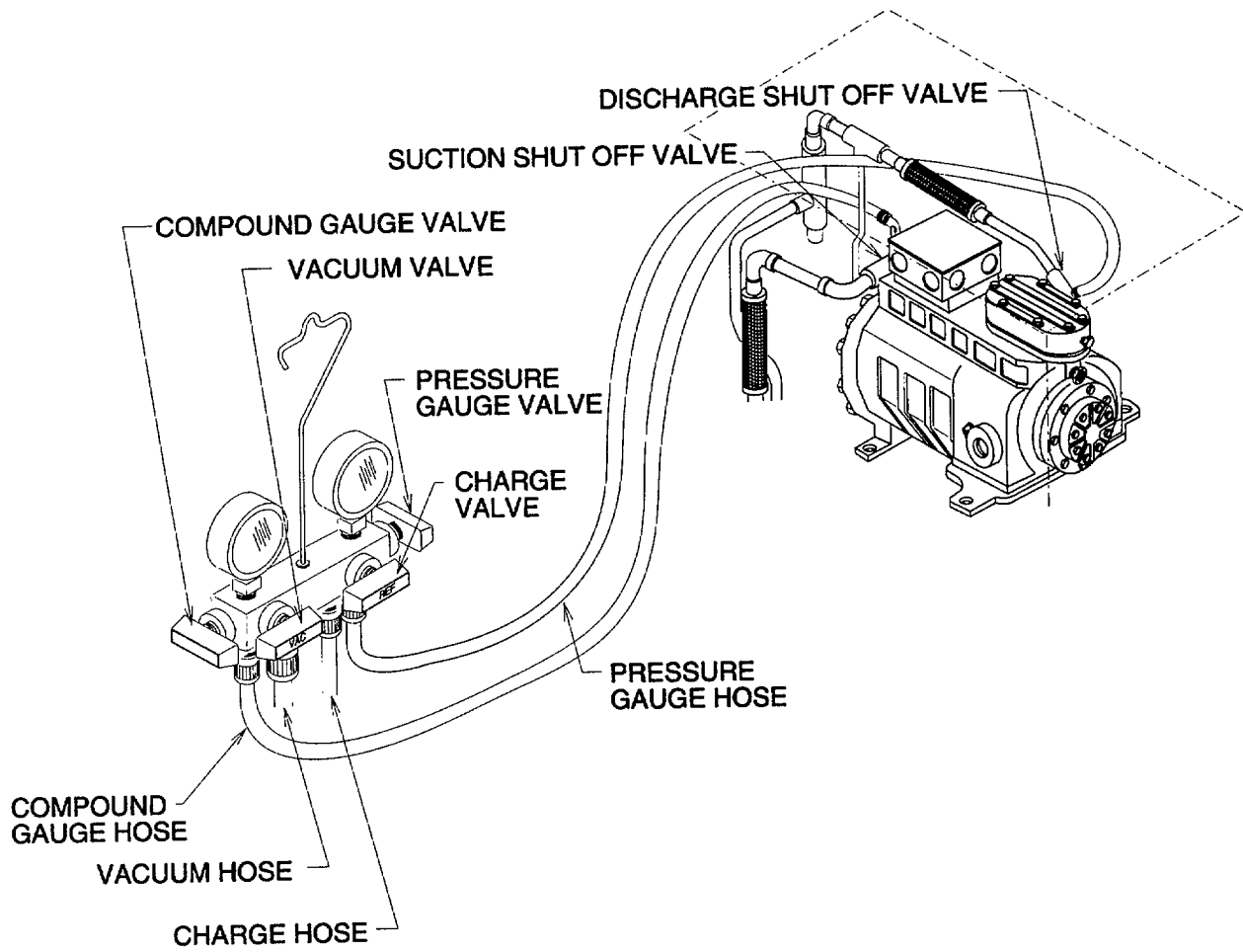

Figure 5-5. Discharging Refrigerant

5-8. PURGING THE REFRIGERANT SYSTEM.

This task covers: Purge

INITIAL SETUPTools:

Nitrogen Regulator
6, Section III, Appendix B

Materials/Parts

Nitrogen
11, Appendix E

Equipment Conditions

Refrigerant system discharged (para 5-7).

General Safety Instructions.**WARNING**

- Never pressurize refrigerant lines with oxygen, mixture with oil could cause an explosion.
- The pressure in a nitrogen cylinder can exceed 2000 psi. A nitrogen pressure regulator should be used at all times to avoid personal injury.
- Nitrogen is an inert gas that can cause suffocation and must be discharged in a well ventilated area.

Purge. The refrigeration system must be purged with dry nitrogen before brazing is performed on any component. A flow of dry nitrogen should be continued during all brazing operations to minimize internal oxidation and scaling.

- (1) Disconnect charge hose from recovery unit and connect to nitrogen regulator and nitrogen tank.
- (2) Disconnect the compound gage hose from the service manifold and place end in a suitable container to catch any oil that may come out.
- (3) Be sure the service manifold compound gage and vacuum valves are closed.
- (4) Open the service manifold pressure gage and charge valves.
- (5) Open the nitrogen tank valve and adjust the regulator so that approximately 1-2 cfm (0.028-0.057 m³/minute) of nitrogen flows through the system
- (6) Check discharge from the hose attached to the suction service valve to be sure that no oil is being forced out of the system
- (7) Perform any brazing/debrazing operations necessary (para 5-9).
- (8) When purging is completed, close nitrogen tank valve.
- (9) Disconnect the charge hose from nitrogen regulator.
- (10) Connect the compound gage hose to service manifold.

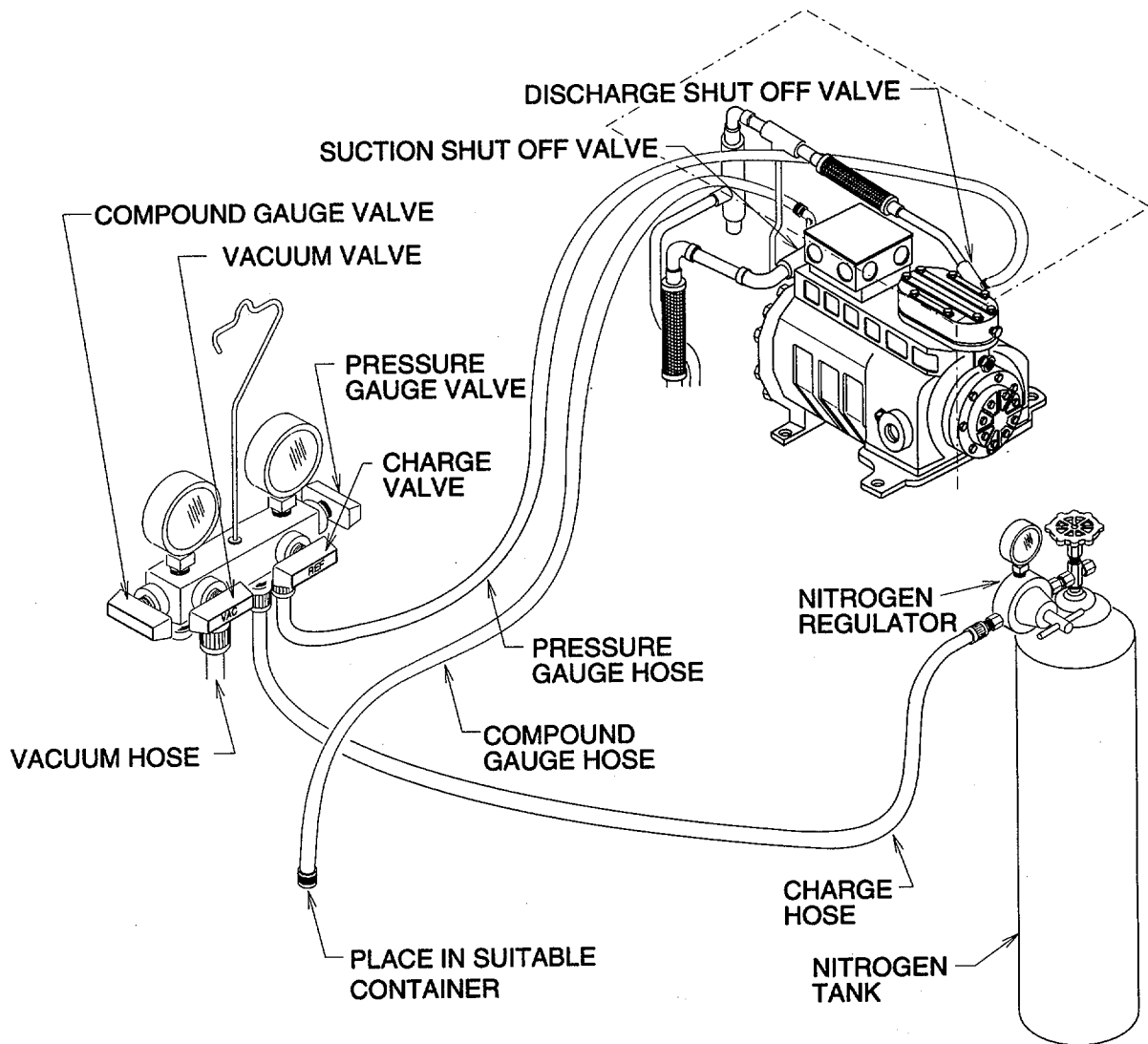

Figure 5-6. Nitrogen Tank Connection

5-9. BRAZING/DEBRAZE PROCEDURE.

This task covers. a. Debraze b. Clean c. Braze

INITIAL SETUPMaterials/Parts

Brazing Alloy
15 or 16, Appendix E
Brazing Flux
9, Appendix E
Rags
3, Appendix E
Abrasive Cloth
13, Appendix E

Equipment Conditions:

Refrigerant system discharged (para 5-7) and purged
(para 5-8).

General Safety Instructions:**WARNING**

Brazing alloys and flux contain materials which are hazardous to health. Avoid breathing vapors or fumes from brazing operations. Perform operations only in well ventilated areas. Wash hands with soap and water after handling brazing alloys and flux. Wear gloves and protective goggles or face shield to protect against burns.

a. Debraze.

- (1) Protect wiring harnesses and other components with appropriate heat shields.

NOTE

It may be easier to access a component by cutting or debrazing the copper lines in accessible areas and removing part of the interconnecting tubing with the component.

- (2) If debrazing a joint on a valve, disassemble the valve to the extent possible and wrap all but the joint with wet rag to act as a heat sink.

WARNING

Never use a heating torch on any part that contains refrigerant. Heat may cause the refrigerant to decompose and release irritating, toxic, and corrosive gases. All refrigerant must be discharged from the system and the entire system must be purged with dry nitrogen before beginning any brazing operation.

CAUTION

If heat is applied slowly, or only on one side, the entire component or length of tubing will be heated and filler alloy in adjacent joints may also be melted

- (3) Check that the system is being purged (para 5-8) and apply sufficient heat uniformly around the joint to quickly melt the filler alloy. Remove heat as soon as the joint is separated

b. Clean. All filler alloy must be cleaned from debrazed joints before reassembly Heat each piece of the joint until the filler is melted and then wipe it away with a wire brush Be sure no filler alloy or other debris is left inside any tubing, fitting, or component Use abrasive cloth as necessary to clean joints.

c. Braze.

(1) Protect wiring harnesses and other components with appropriate heat shields.

NOTE

- All joints, except those provided with flare fittings, are made by brazing in accordance with MIL-B-7883, except that radiographic examination is not required.
- Grade IV or VI brazing alloy and Type-B flux, as specified in MIL-B-7883, must be used for all copper to brass joints. Grade III brazing alloy may be substituted for Grade IV or VI for copper to copper joints, flux is not required for copper to copper joints.

(2) If brazing a joint on a valve, disassemble the valve to the extent possible and wrap all but the joint with a wet rag to act as a heat sink.

NOTE

If interconnecting tubing was removed with a component, braze tubing to the new components before installation.

(3) Position component or assembly into place.

WARNING

Never use a heating torch on any part that contains refrigerant Heat may cause the refrigerant to decompose and release irritating, toxic, and corrosive gases. All refrigerant must be discharged from the system and the entire system must be purged with dry nitrogen before beginning any brazing operation.

CAUTION

- If heat is applied slowly, or only on one side, the entire component or length of tubing will be heated and filler alloy in adjacent joints may also be melted.
- Brazing a joint without nitrogen flowing through the tubing, will cause deposits to form on the inside of the tube and may cause obstructions in the refrigeration system or equipment damage.

(4) Check that the system is being purged (para 5-8) and apply sufficient heat uniformly around the joint to quickly melt the filler alloy Remove heat and stop purging (para 5-8) as soon as brazing is completed.

5-10. LEAK TESTING THE REFRIGERANT SYSTEM.

This task covers. Testing

INITIAL SETUPTools:

Refrigeration Unit Service Tool Kit

4, Section III, Appendix B

Nitrogen Regulator

6, Section III, Appendix B

Equipment Conditions:

Service manifold installed para 5-6).

Materials/Parts-

Refrigerant R-134a

12, Appendix E

Nitrogen

11, Appendix E

General Safety Instructions:**WARNING**

- Never pressurize refrigerant lines with oxygen, mixture with oil could cause an explosion.
- The pressure in a nitrogen cylinder can exceed 2000 psi. A nitrogen pressure regulator should be used at all times to avoid personal injury.
- Nitrogen is an inert gas that can cause suffocation and must be discharged in a well ventilated area.

Testing.**NOTE**

- To perform leak test, it is necessary that the system be pressurized with a proportion of refrigerant gas.
- The electronic gas tester is highly sensitive to the presence of a minute quantity of gas in the air, and is quite effective in the detection of small leaks. However, due to rapid dispersion of refrigerant gas into surrounding air, difficulty may be encountered in pinpointing large leaks. The detector must be used in a well ventilated area but draft free area. Use procedures contained in TM 9-4940-435-14, "Leak Detector, Refrigerant Gas".

(1) To pressurize a system that has some refrigerant charge.

(a) Connect the charge hose to a refrigerant cylinder containing refrigerant R-134a set to deliver gas only.

(b) Check that service manifold vacuum valve is closed.

(c) Open the service manifold compound gage, pressure gage, and charge valves.

(d) Open refrigerant cylinder valve and pressurize system to 100 psi (7.1 kg/cm²).

- (2) To pressurize a system that has been discharged and purged.
 - (a) Connect the charge hose to a refrigerant cylinder containing refrigerant R-134a set to deliver gas only.
 - (b) Check that service manifold vacuum valve is closed.
 - (c) Open the service manifold compound gage, pressure gage, and charge valves.
 - (d) Open refrigerant cylinder valve and pressurize system to 40-50 psi (2 8-3 5 kg/cm²).
 - (e) Close service manifold valves and refrigerant cylinder valve.
 - (f) Disconnect charge hose from the refrigerant cylinder and connect it to a nitrogen regulator and nitrogen cylinder.
 - (g) Open the service manifold compound gage, pressure gage, and charge valves.
 - (h) Open nitrogen cylinder valve and pressurize system to 350 psi (24 7 kg/cm²).
- (3) Test for leaks at all points of possible leakage using a refrigerant gas leak detector. If a leak is found, take necessary steps to replace damaged components or repair leak.
- (4) If no leak was found and refrigerant only was used to pressurize the system, check refrigeration unit charge (para 5-12).
- (5) If no leak was found and nitrogen was used to pressurize the system, discharge (para 5-7), evacuate (para 5-11), and charge (para 5-12) the refrigeration unit.

5-11. EVACUATING THE REFRIGERANT SYSTEM.

This task covers: Evacuate

INITIAL SETUP

Tools:

Refrigeration Unit Service Tool Kit
4, Section III, Appendix B

Equipment Conditions:

Refrigerant system discharged (para 5-7).

Evacuate. The refrigeration system must be evacuated to remove all moisture and non-condensable before it is charged.

- (1) Check that new dehydrator was installed. If not, install one (para 5-14).

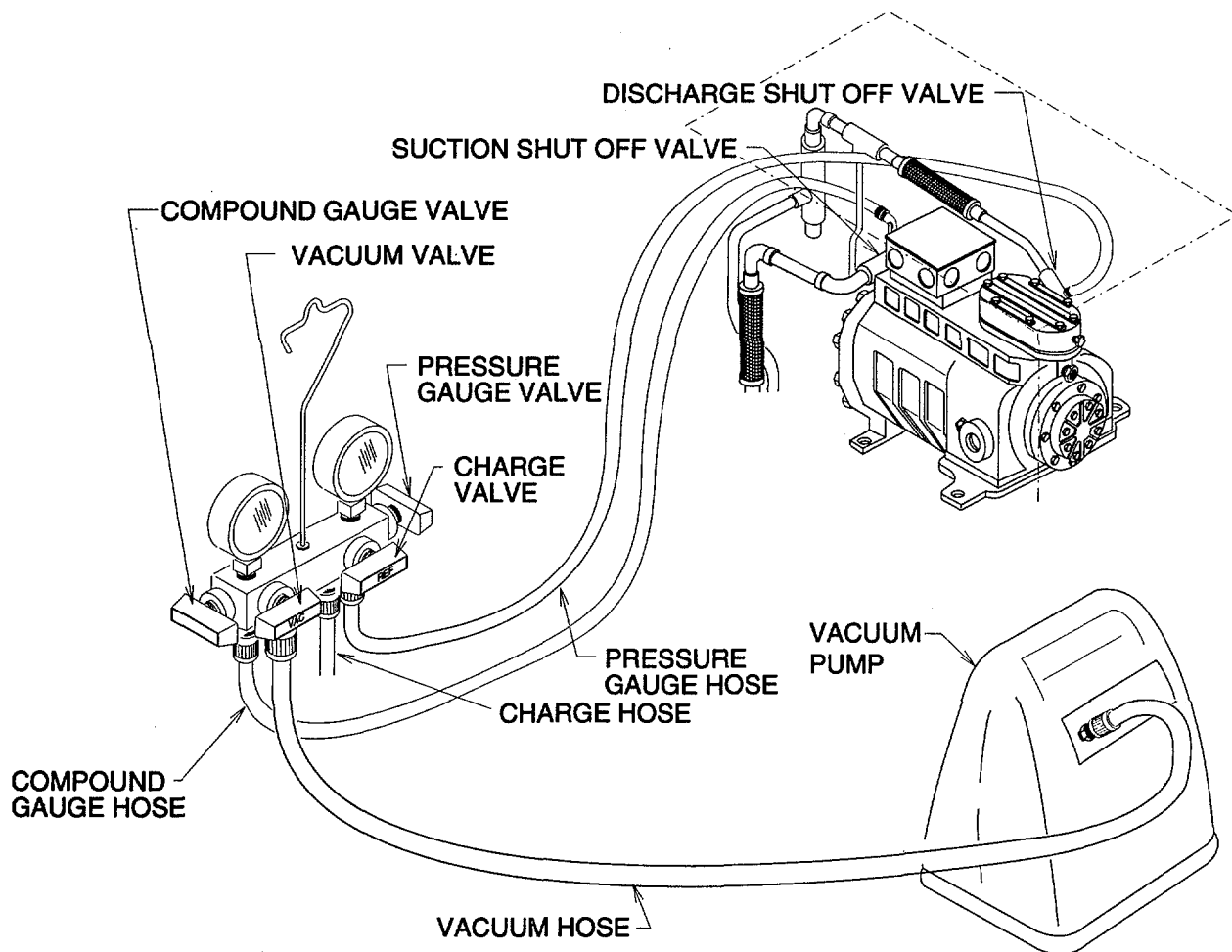

Figure 5-7. Evacuation of Refrigerant System

- (2) Check that service manifold charge valve is closed.
- (3) Connect the vacuum hose to vacuum pump and start pump.
- (4) Open service manifold high pressure gauge, compound gauge, and vacuum valves.
- (5) Run vacuum pump until at least 29 inches of mercury is measured on compound gage. Continue running vacuum pump for one more hour, while observing the compound gauge. If gage needle moves back and forth, you have a leak which must be located and corrected (para 5-14).

NOTE

Inability to reach and hold 29 inches of mercury may indicate either a leak or a problem with the vacuum pump

- (6) Close service manifold vacuum valve and stop vacuum pump. Note reading on compound gauge and observe for 10 minutes. If pressure rises, moisture may still be in the system or a leak exists. If pressure rose, repeat evacuation and re-check. If the pressure rise occurs again at the same speed, a leak is in the system and must be found (para 5-14). If the pressure rise was slower the second time, moisture remains in the system and the evacuation process must be repeated until there is no rise.
- (7) Close service manifold high pressure gauge and compound gauge valves.
- (8) Disconnect the vacuum hose from vacuum pump.

NOTE

FOLLOW-ON MAINTENANCE:
Charge the refrigeration system (para 5-12).

5-12. CHARGING THE REFRIGERANT SYSTEM.

This task covers: a. Full Charge b. Partial Charge

INITIAL SETUPEquipment Conditions:

Service manifold installed (para 5-6)
 Refrigerant system evacuated (para 5-11).

Materials/Parts:

Refrigerant R-134a
 12, Appendix E

General Safety Instructions:**WARNING**

- Dangerous chemical refrigerant under pressure is used in the operation of this equipment. Use great care to avoid contact with liquid refrigerant.
- Sudden and irreversible tissue damage can result from freezing. Wear gloves and a face protector or safety glasses in any situation where skin or eye contact with refrigerant is possible.
- Heat may cause the refrigerant to decompose and release irritating, toxic, and corrosive gases. Prevent contact of refrigerant with flame or hot surfaces.
- Never introduce high discharge pressure into a refrigerant cylinder. This can cause the cylinder to rupture and injure personnel.

a. Full Charge.**CAUTION**

The system must be evacuated before charging. Moisture in the system will prevent the refrigeration unit from operating properly.

- (1) Connect the charge hose to a tank containing refrigerant R-134a set to deliver gas and the vacuum hose to reclaim unit.
- (2) Check that compound gauge and pressure gauge valves are closed.
- (3) Open vacuum and charge valves.
- (4) Open refrigerant tank valve. Operate reclaim unit for 3 to 5 seconds to purge hoses.
- (5) Close refrigerant tank, vacuum, and charge valves then stop reclaim unit.

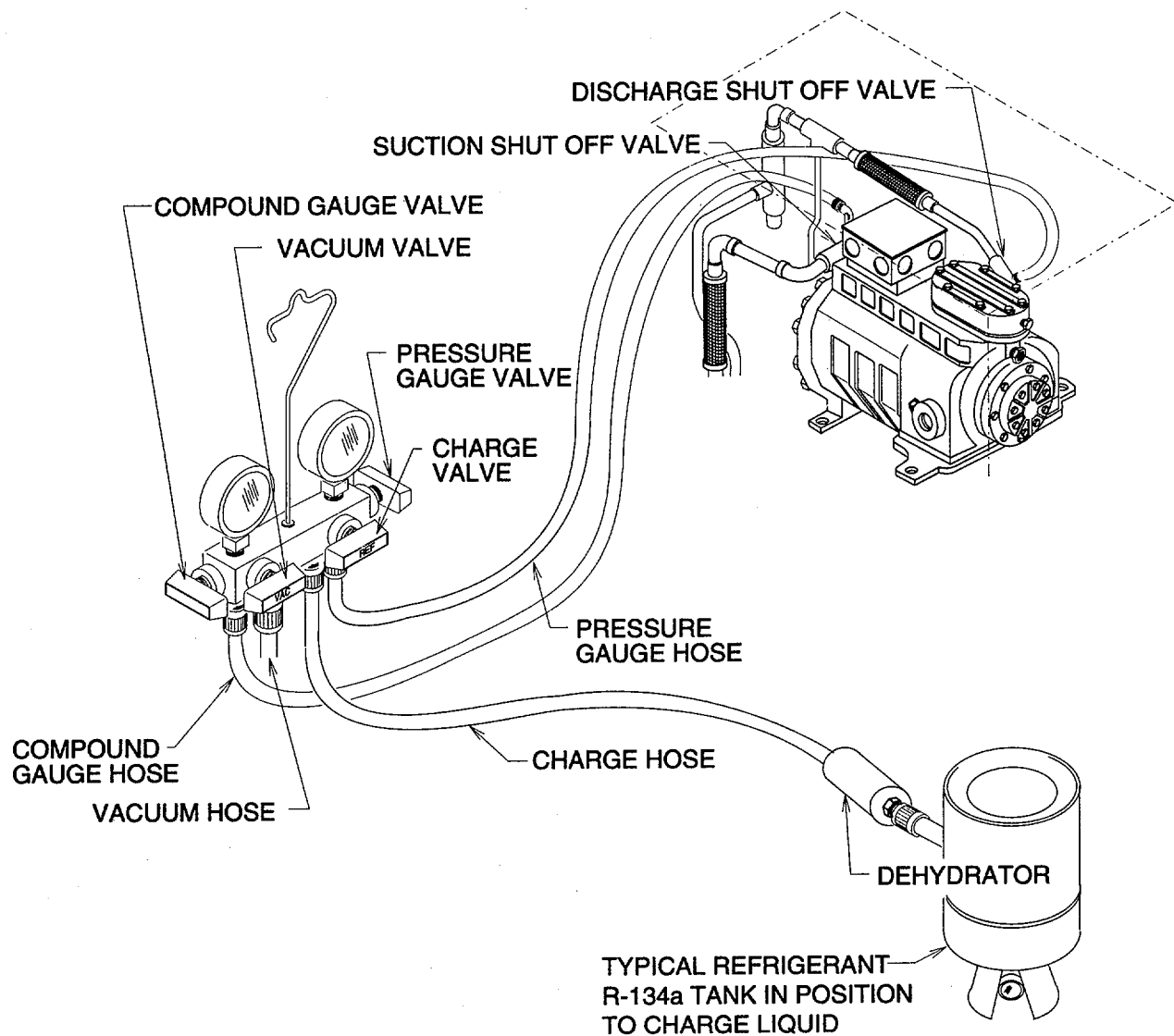

Figure 5-8. Refrigerant Charging (Total System)

- (6) Set refrigerant tank to deliver liquid only.
- (7) Place refrigerant tank on an accurate scale to measure and record weight.

CAUTION

Never introduce liquid refrigerant into the suction shut off valve. This can cause damage to the compressor.

- (8) With system shutdown, open refrigerant tank, pressure gauge, and charge valves. Allow liquid refrigerant to enter system until tank weight has decreased by 10 pounds (4.5 kg) or until system pressure has equalized, whichever occurs first.

5-12. CHARGING THE REFRIGERANT SYSTEM. - Continued

- (9) Close refrigerant tank, charge, and pressure gauge valves.

NOTE

If 10 pounds (4.5 kg) full charge was obtained, skip steps (10) through (15).

- (10) Connect power at power source.
 (11) Turn refrigeration unit on (para 4-7) and operate at desired temperature setting.
 (12) Set refrigerant tank to deliver gas only.
 (13) Check that all service manifold valves are closed.

WARNING

Never introduce high discharge pressure into a refrigerant tank. This can cause the tank to rupture and injure personnel.

CAUTION

Never introduce liquid refrigerant into the suction shut off valve. This can cause damage to the compressor.

- (14) Open refrigerant tank, compound gauge, and charge valves.
 (15) Motor weight of the refrigerant tank until total 10 pounds (4.5 kg) charge is obtained. When system is fully charged, immediately close refrigerant tank, compound gauge, and charge valves.
 (16) Run refrigeration unit for 15 minutes and observe sight glass through left side door.
 (a) Green or chartreuse center means refrigerant moisture content is acceptable.
 (b) Yellow center means there is too much moisture in system. Discharge (para 5-7), replace dehydrator (para 5-14), leak check (para 5-10), evacuate (para 5-11), and charge again.
 (17) Be sure all service manifold valves are closed.
 (18) Shut off refrigeration unit (para 2-7).

b. Partial Charge.

- (1) Connect the charge hose to a tank containing refrigerant R-134a set to deliver gas and the vacuum hose to reclaim unit.
 (2) Check that compound gauge and pressure gauge valves are closed.
 (3) Open vacuum and charge valves.
 (4) Open refrigerant tank valve. Operate reclaim unit for 3 to 5 seconds to purge hoses.

- (5) Close refrigerant tank, vacuum, and charge valves then stop reclaim unit.
- (6) Connect power at power source.
- (7) Turn refrigeration unit on (para 4-7) and operate at desired temperature setting.
- (8) Set refrigerant tank to deliver gas only.
- (9) Check that all service manifold valves are closed.

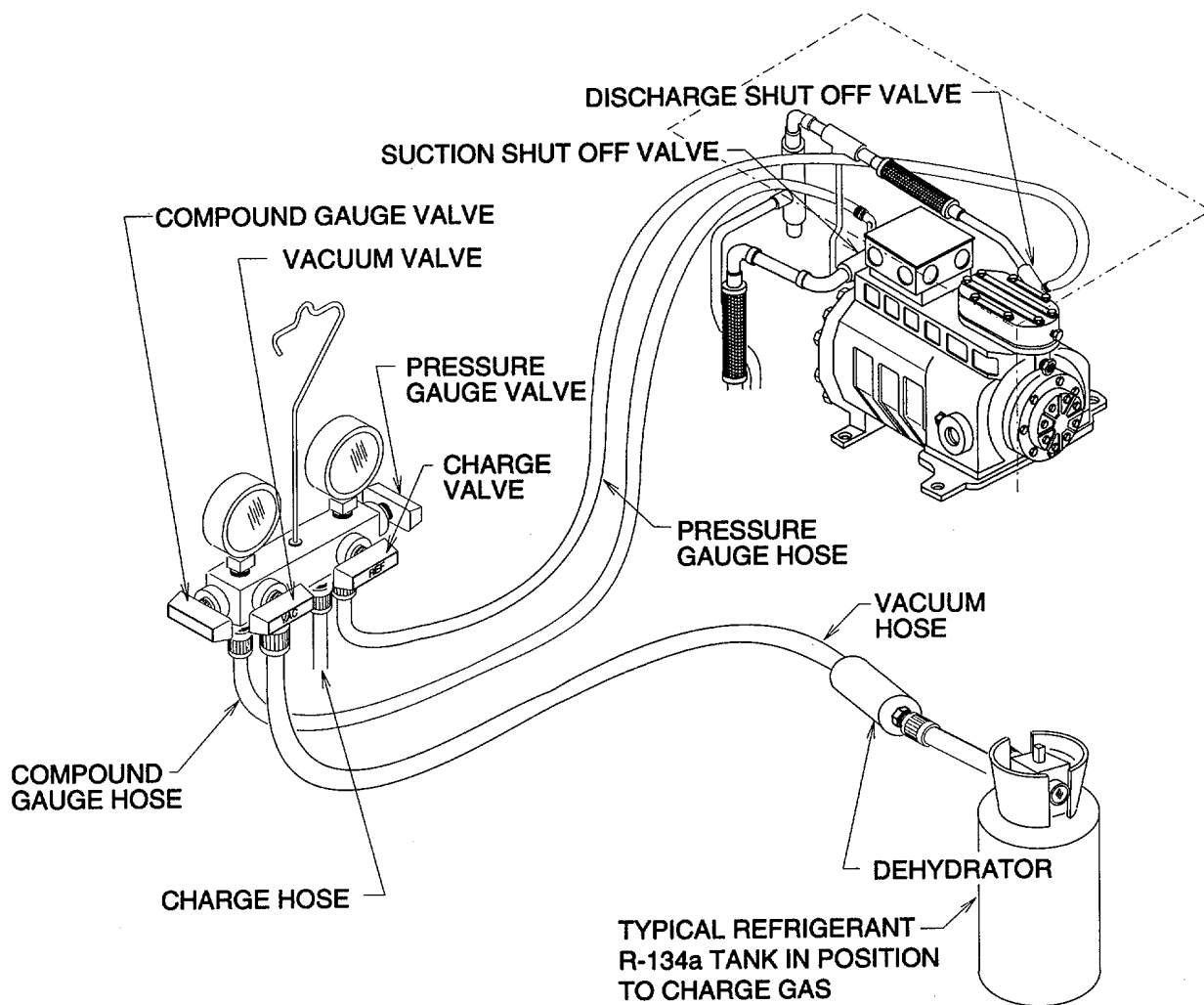

Figure 5-9. Refrigerant Charging (Partial System /Small Quantity Charge)

5-12. CHARGING THE REFRIGERANT SYSTEM. - Continued

WARNING

Never introduce high discharge pressure into a refrigerant tank. This can cause the tank to rupture and injure personnel.

CAUTION

Never introduce liquid refrigerant into the suction shut off valve. This can cause damage to the compressor.

- (10) Open refrigerant tank, compound gauge, and charge valves.
- (11) Run refrigeration unit for 15 minutes and observe sight glass through left side door.
 - (a) Green or chartreuse center means refrigerant moisture content is acceptable.
 - (b) Yellow center means there is too much moisture in system. Discharge (para 5-7), replace dehydrator (para 5-14), leak check (para 5-10), evacuate (para 5-11), and charge again.
 - (c) Milky white or bubbly liquid means system has low charge.
 - (d) Clean bubble free liquid around center means the system is fully charged.

CAUTION

Never introduce liquid refrigerant into the low pressure (suction) charging valve. This can cause damage to the compressor.

- (12) If charge is low, set refrigerant tank to deliver gas only.

WARNING

Never introduce high discharge pressure into a refrigerant cylinder. This can cause the cylinder to rupture and injure personnel.

- (13) Check that pressure gauge valve is closed.
- (14) Open refrigerant tank, compound gauge, and charge valves.
- (15) Charge until sight glass remains clear and bubble free for 15 minutes.
- (16) When system is fully charged, immediately close refrigerant tank, compound gauge, and charge valves.
- (17) Shut off refrigeration unit (para 2-7).

NOTE

FOLLOW-ON MAINTENANCE:-
Remove service manifold (para 5-6)

5-13. REFRIGERANT SYSTEM PRESSURE CHECK.

This task covers: Testing

INITIAL SETUP

Equipment Conditions

Service manifold installed (para 5-6)

Testing.

- (1) Check that all four service manifold valves are closed
- (2) Service manifold compound and pressure gauges should indicate the same pressure Check the reading with the appropriate column m Table 5-1 If the system is even partially charged, the pressure should be approximately equal to that shown m the table for the appropriate ambient temperature If the pressure is considerably less than shown m the table, the system does not contain enough refrigerant to continue the pressure check. Leak test the refrigeration system (para 5-10).
- (3) Turn the refrigeration unit on (para 4-7) and operate at desired setting.
- (4) With the refrigeration unit operating, allow service manifold gauges to stabilize. Compare readings with those listed m Table 5-1.
 - (a) If discharge and suction pressure are at, or near, the same value, defrost solenoid valve (L2) or compressor (B1) failure is indicated.
 - (b) If discharge pressure is low and suction pressure is normal, a low refrigerant charge is indicated If charge is correct, refer to troubleshooting procedure (para 5-1).
 - (c) If discharge pressure is normal and suction pressure is either high, or low, failure of the expansion valve is indicated If discharge pressure is high and suction pressure is normal, refrigerant overcharge is indicated.
- (5) When pressure tests are completed, turn the refrigeration unit off (para 2-7) and disconnect power.

Table 5-1. Pressure Temperature Relationship of Saturated Refrigerant R-134a

Temperature		Pressure		Temperature		Pressure	
Deg F	Deg C	psia	kg/cm2	Deg F	Deg C	psia	kg/cm2
-20	-28.88	12.95	5.87	-2	-18.88	20.23	9.17
-18	-27.77	13.63	6.18	0	-17.77	21.20	9.61
-16	-26.66	14.35	6.50	2	-16.66	22.22	10.07
-14	-25.55	15.09	6.84	4	-15.55	23.27	10.55
-12	-24.44	15.87	7.19	6	-14.44	24.35	11.04
-10	-23.33	16.67	7.56	8	-13.33	25.48	11.55
-8	-22.22	17.51	7.94	10	-12.22	26.65	12.08
-6	-21.11	18.38	8.33	12	-11.11	27.86	12.63
-4	-20.00	19.29	8.74	14	-10.00	29.11	13.20

5-13. REFRIGERANT SYSTEM PRESSURE CHECK. - Continued

Table 5-1. Pressure Temperature Relationship of Saturated Refrigerant R-134a

Temperature		Pressure	
Deg F	Deg C	psia	kg/cm2
16	-8.88	30.41	13.79
18	-7.77	31.75	14.40
20	-6.66	33.14	15.03
22	-5.55	34.57	15.68
24	-4.44	36.05	16.35
26	-3.33	37.58	16.78
28	-2.22	39.16	17.76
30	-1.11	40.79	18.50
32	0.00	42.47	19.26
34	1.11	44.21	20.05
36	2.22	45.99	20.86
38	3.33	47.84	21.69
40	4.44	49.74	22.56
42	5.55	51.70	23.45
44	6.66	53.71	24.36
46	7.77	55.79	25.30
48	8.88	57.93	26.27
50	10.00	60.13	27.27
52	11.11	62.39	28.29
54	12.22	64.71	29.35
56	13.33	67.11	30.44
58	14.44	69.57	31.55
60	15.55	72.09	32.69
62	16.66	74.69	33.87
64	17.77	77.36	35.08
66	18.88	80.09	36.32
68	20.00	82.90	37.60
70	21.11	85.79	38.91
72	22.22	88.75	40.25
74	23.33	91.79	41.63
76	24.44	94.90	43.04
78	25.55	98.09	44.49
80	26.66	101.37	45.98
82	27.77	104.73	47.50
84	28.88	108.16	49.06
86	30.00	111.69	50.66
88	31.11	115.30	52.16

Temperature		Pressure	
Deg F	Deg C	psia	kg/cm2
90	32.22	118.99	53.97
92	33.33	122.78	55.69
94	34.44	126.65	57.44
96	35.55	130.62	59.24
98	36.66	134.68	61.08
100	37.77	138.83	62.59
102	38.88	143.07	64.86
104	40.00	147.42	66.86
106	41.11	151.86	68.88
108	42.22	158.40	71.84
110	43.33	161.04	73.04
112	44.44	165.79	75.20
114	45.55	170.64	77.40
116	46.66	175.59	79.64
118	47.77	180.65	82.58
120	48.88	185.82	84.28
122	50.00	191.11	86.68
124	51.11	196.50	89.13
126	52.22	202.00	91.62
128	53.33	207.62	94.17
130	54.44	213.36	96.77
132	55.55	219.22	99.43
134	56.66	225.19	102.14
136	57.77	231.29	104.91
138	58.88	237.51	107.73
140	60.00	243.86	110.06
142	61.11	250.33	113.54
144	62.22	256.94	116.54
146	63.33	263.67	119.59
148	64.44	270.54	122.71
150	65.55	277.54	125.89
152	66.66	284.67	129.12
154	67.77	291.95	132.42
156	68.88	299.37	135.79
158	70.00	306.64	139.08
160	71.11	314.64	142.71

Table 5-2. Nominal Operating Pressure At Suction And Discharge Shut Off Valves

Air Temperature Entering Evaporator Coil	Air Temperature Entering Condenser Coil 1100 F (43° C)
0° F (-18° C)	Suction 1 psi (7 kPa) Discharge 177 psi (1221 kPa)
40° F (4° C)	Suction 10 psi (69 kPa) Discharge 199 psi (1373 kPa)

NOTE

FOLLOW-ON MAINTENANCE:
Remove service manifold (para 5-10).

5-14. DEHYDRATOR REPLACEMENT.

This task covers: a Removal b Installation

INITIAL SETUPMaterials/Parts:

Lock Washers
1, Appendix G

Equipment Conditions:

Refrigeration system discharged (para 5-7).
Right side door open.
Front bottom door open.

a. Removal.

(1) Loosen two flare nuts (1).

NOTE

Note flow direction prior to removal.

(2) Remove bolt (2), lock washer (3), clamp (4), and dehydrator (5). Discard lock washer.

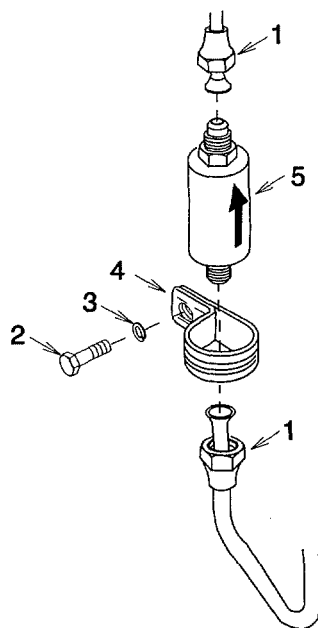

Figure 5-10. Dehydrator

b. Installation.

NOTE

- Do not remove dehydrator protective caps until just before installation. This will minimize the risk of contaminating the dehydrator.
- Be sure to observe flow direction noted during removal.

(1) Install new dehydrator (5), clamp (4), new lock washer (3), and bolt (2).

(2) Tighten two flare nuts (1).

NOTE

FOLLOW-ON MAINTENANCE:

Close right side door.

Close front bottom door.

Leak check (para 5-10), evacuate (para 5-11), and charge (para 5-12) the refrigeration system.

5-15. STRAINER REPLACEMENT.

This task covers: a. Removal b. Installation

INITIAL SETUP

Materials/Parts.
 Lock Washer
 1 Appendix G
 Front bottom door open

Equipment Conditions.
 Refrigeration system discharged (para 5-7).
 Right side door open.

a. Removal.

(1) Loosen two flare nuts (1).

NOTE

Note flow direction prior to removal.

(2) Remove bolt (2), lock washer (3), spacer (4), clamp (5), and strainer (6). Discard lock washer.

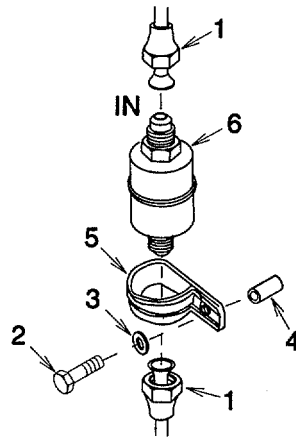

Figure 5-11. Strainer

b. Installation.

NOTE

Be sure to observe flow direction noted during removal.

- (1) Install strainer (6), clamp (5), spacer (4), bolt (2), and new lock washer (3).
- (2) Tighten two flare nuts (1).

NOTE

FOLLOW-ON MAINTENANCE:
Replace dehydrator (para 5-14).

Leak check (para 5-10), evacuate (para 5-11), and charge (para 5-12) the refrigeration system.

5-16. ISOLATION VALVES REPLACEMENT.

This task covers. a Removal b. Installation

INITIAL SETUP

Materials/Parts:

Teflon Seal (2)
5, Appendix G

Equipment Conditions:

Right side door open.
Refrigeration system discharged (para 5-7).

a. Removal.

- (1) Remove two isolation valve caps (1).
- (2) Loosen two flare nuts (2) and move copper tubing (3) away from isolation valve (4) being careful not to bend or kink tubing.

NOTE

Isolation valve flare connections are different sizes Note location prior to removal.

- (3) Remove two isolation valves (4) and teflon seals (5).

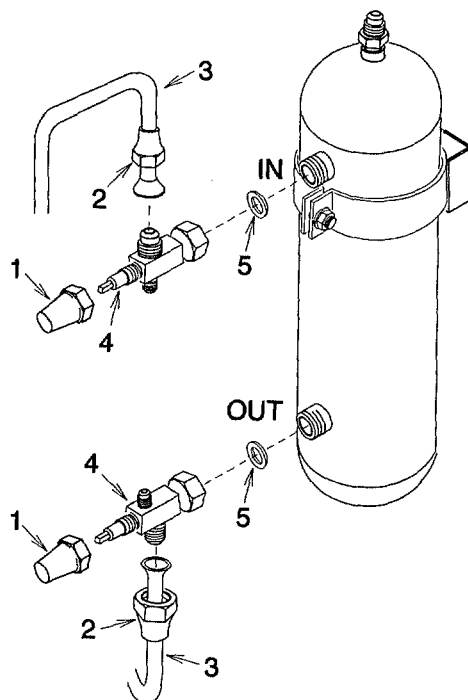

Figure 5-12. Isolation Valves

b. Installation.

NOTE

Isolation valve flare connections are different sizes. Be sure to observe location noted during removal.

- (1) Install two teflon seals (5), and isolation valve (4).
- (2) Tighten isolation valves (4) to between 50 and 60 ft lb (68 Nm and 82 Nm) Be sure valves are turned toward copper tubing (3) when tightened.
- (3) Aline copper tubing (3) and connect two flare nuts (2) to isolation valves (4).
- (4) Be sure two isolation valves (4) are open and metal two isolation valve caps (1).

NOTE

FOLLOW-ON MAINTENANCE:

Replace dehydrator (para 5-14).

Leak check (para 5-10), evacuate (para 5-11), and charge (para 5-12) the refrigeration system.

5-17. RECEIVER AND FUSIBLE PLUG REPLACEMENT.

This task covers: a. Removal b. Installation

INITIAL SETUP

Materials/Parts:

Self Locking Nuts (2)
15, Appendix G
Lubricating Oil
21, Appendix E

Equipment Conditions:

Right side door open.
Refrigeration system discharged (para 5-7).
Isolation valves removed (para 5-16).

General Safety Instructions:

WARNING

Compressor lubricating oil used in this refrigeration system is caustic. Wear gloves and a face protector or safety glasses in any situation where skin or eye contact is possible. If oil does contact skin, wash with soap and water.

a. Removal.

(1) Remove self locking nut (1), flat washer (2), bolt (3), and flat washer (4). Discard self locking nut.

NOTE

Note flow direction prior to removal.

(2) Remove self locking nut (5), flat washer (6), and receiver (7) Discard self locking nut.

(3) Remove fusible plug (8).

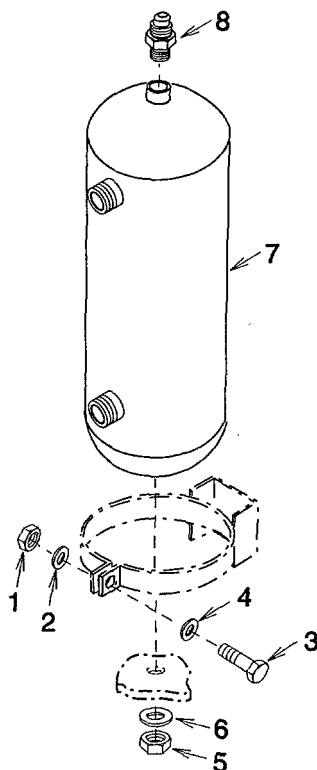

Figure 5-13. Receiver

b. Installation.

- (1) Lightly coat fusible plug (8) copper gasket with compressor oil.
- (2) Install fusible plug (8) and tighten to between 25 and 30 ft lb (33.9 and 40.68 Nm).

NOTE

Be sure to observe flow direction noted during removal.

- (3) Install receiver (7), flat washer (6), and new self locking nut (5).
- (4) Install flat washers (4), bolt (3), flat washer (2), and new self locking nut (1).

NOTE

FOLLOW-ON MAINTENANCE:
 Install isolation valves (para 5-16).
 Replace dehydrator (para 5-14).

Leak check (para 5-10), evacuate (para 5-11), and charge (para 5-12) the refrigeration system.
 Close right side door.

5-18. CONDENSER COIL REPLACEMENT.

This task covers: a. Removal b. Installation

INITIAL SETUP

Materials/Parts:

Self Locking Nuts (6)
25, Appendix G
Lock Washers (6)
1, Appendix G

Equipment Conditions:

Refrigeration system discharged (para 5-7) and
purged (para 5-8).
Both side doors open.
Coil guard front panel removed (para 4-17).

a. Removal.

- (1) Remove six bolts (1), lock washers (2), and clamps (3). Discard lock washers.
- (2) De-braze two fittings (4) from condenser coil (5) (para 5-9).

WARNING

Coil fins are sharp and can cut hands or fingers. Wear gloves to prevent personal injury when handling coil.

- (3) Remove six self locking nuts (6), bolts (7), flat washers (8), and condenser coil (5). Discard self locking nuts.
- (4) Remove condenser shroud (9).

b. Installation.

- (1) Install condenser shroud (9).

WARNING

Coil fins are sharp and can cut hands or fingers. Wear gloves to prevent personal injury when handling coil.

- (2) Align condenser coil (5) with shroud (9), and install six flat washers (8), bolts (7), and new self locking nuts (6).

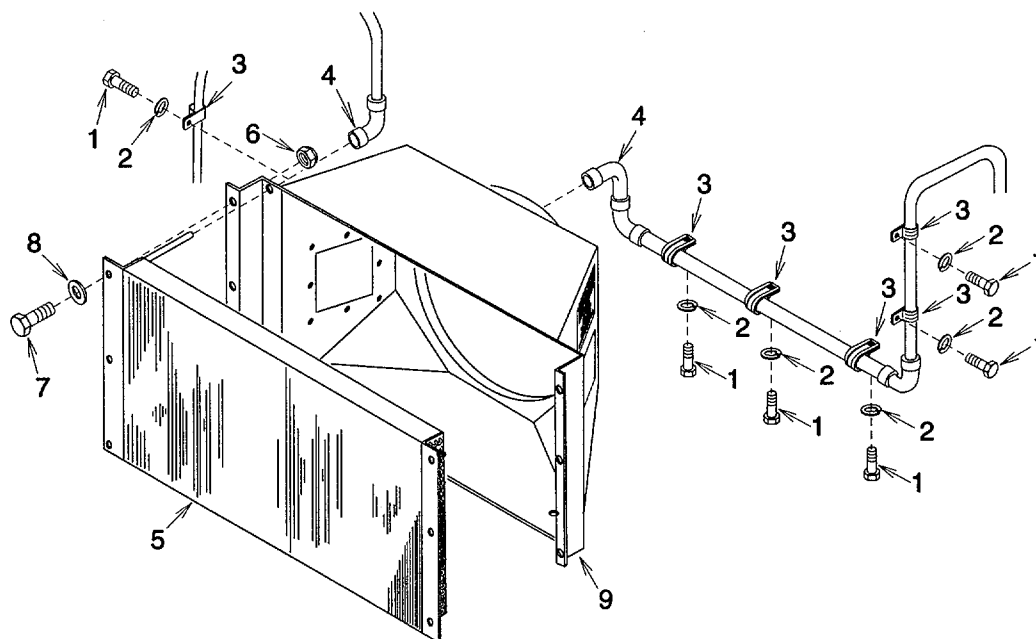

Figure 5-14. Condenser Coil

(3) Braze two fittings (4) onto condenser coil (5) (para 5-9).

(4) Install six clamps (3), new lock washers (2), and bolts (1).

NOTE

FOLLOW-ON MAINTENANCE:

Close left side door.

Install coil guard front panel (para 4-17).

Replace dehydrator (para 5-14).

Leak check (para 5-10), evacuate (para 5-11), and charge (para 5-12) the refrigeration system.

5-19. PRESSURE REGULATOR VALVE (DISCHARGE) REPLACEMENT.

This task covers. a. Removal b. Installation

INITIAL SETUP

Materials/Parts:

Lock Washer
1, Appendix G

Equipment Conditions:

Refrigeration system discharged (para 5-7) and
purged (para 5-8)
Left side door open

a. Removal.

- (1) De-braze two fittings (1) and bushings (2) from pressure regulator valve (3) (para 5-9).
- (2) Remove bolt (4), lock washer (5), pressure regulator valve (3), and clamp (6). Discard lock washer.

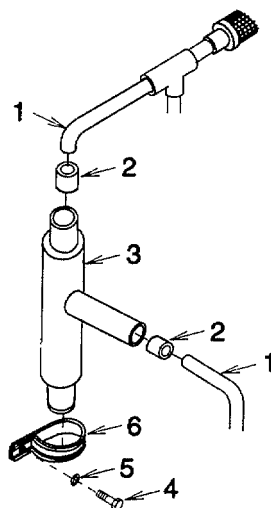

Figure 5-15. Pressure Regulator Valve

b. Installation

- (1) Install clamp (6) onto pressure regulator valve (3) and align clamp. Install new lock washer (5) and bolt (4).
- (2) Braze two bushings (2) and fittings (1), onto pressure regulator valve (3) (para 5-9).

NOTE

FOLLOW-ON MAINTENANCE:

Close left side door

Replace dehydrator (para 5-14)

Leak check (para 5-10), evacuate (para 5-11), and charge (para 5-12) the refrigeration system

5-20. METAL HOSE ASSEMBLY (DISCHARGE) REPLACEMENT.

This task covers: a Removal b Installation

INITIAL SETUP

Equipment Conditions:

Refrigeration system discharged (para 5-7) and
 purged (para 5-8).
 Left side door open.
 Top access panel removed (para 4-14)

- a. Removal. De-braze two fittings (1) (para 5-9) and remove metal hose assembly (2)

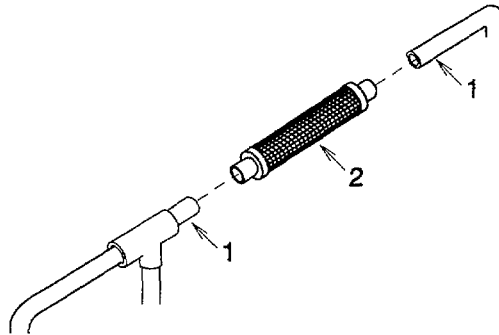

Figure 5-16. Metal Hose Assembly

- b. Installation. Install metal hose assembly (2) and braze two fittings (1) (para 5-9)

NOTE

FOLLOW-ON MAINTENANCE.
 Close left side door.
 Install top access panel (para 4-14)
 Replace dehydrator (para 5-14)
 Leak check (para 5-10), evacuate (para 5-11), and charge (para 5-12) the refrigeration system

5-21 PRESSURE REGULATOR VALVE (SUCTION) REPLACEMENT

This task covers: a Removal b Installation

INITIAL SETUP

Materials/Parts-

Lock Washer
 1, Appendix G
 Insulation Tape
 10, Appendix E

Equipment Conditions:

Refrigeration system discharged (para 5-7) and
 purged (para 5-8).
 Left side door open

a Removal

- (1) Remove insulation (1) as necessary from pressure regulator valve (2) and fittings (3).
- (2) De-braze two fittings (3) from pressure regulator valve (2) (para 5-9)
- (3) Remove bolt (4), lock washer (5), pressure regulator valve (2), and clamp (6). Discard lock washer.

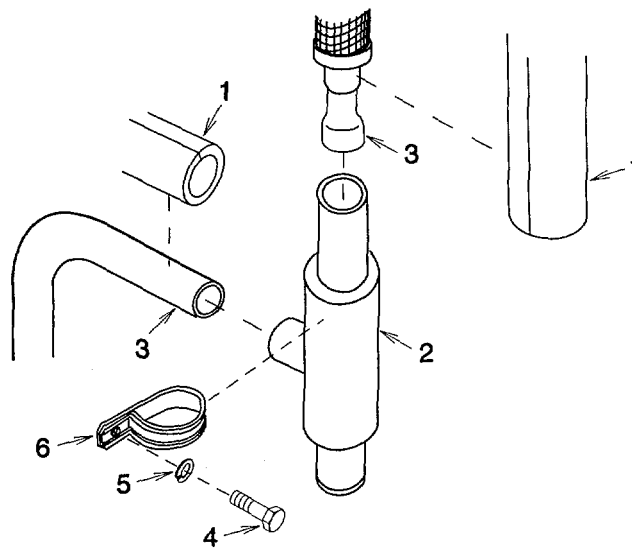

Figure 5-17. Pressure Regulator Valve

5-21. PRESSURE REGULATOR VALVE (SUCTION) REPLACEMENT. - Continuedb Installation.

- (1) Install clamp (6) onto pressure regulator valve (2) and align clamp. Install new lock washer (5) and bolt (4).
- (2) Braze two fittings (3) onto pressure regulator valve (2) (para 5-9).
- (3) Install insulation (1) over fittings (3) and pressure regulator valve (2). Secure with insulation tape as necessary.

NOTE

FOLLOW-ON MAINTENANCE-

Close left side door.

Replace dehydrator (para 5-14).

Leak check (para 5-10), evacuate (para 5-11), and charge (para 5-12) the refrigeration system.

5-22. METAL HOSE ASSEMBLY (SUCTION) REPLACEMENT.

This task covers: a Removal b. Installation

INITIAL SETUP

Materials/Parts

Insulation Tape
10, Appendix E

Equipment Conditions.

Refrigeration system discharged (para 5-7) and
purged (para 5-8).
Left side door open

a Removal.

- (1) Remove insulation (1) as necessary
- (2) De-braze two fittings (2) and remove metal hose assembly (3)

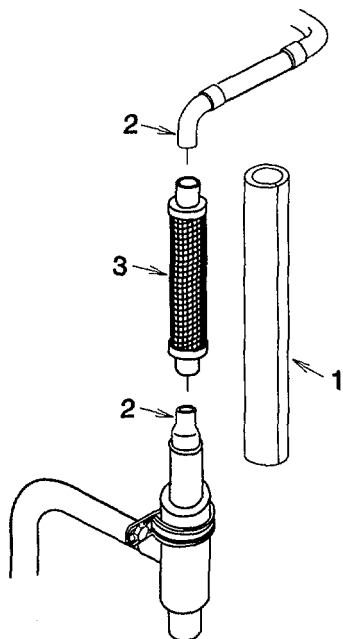

Figure 5-18. Metal Hose Assembly

5-22. METAL HOSE ASSEMBLY (SUCTION) REPLACEMENT. - Continued

b. Installation.

- (1) Install metal hose assembly (3) and braze two fittings (2) (para 5-9).
- (2) Install insulation (1) and secure with insulation tape as necessary

NOTE

FOLLOW-ON MAINTENANCE-

Close left side door.

Replace dehydrator (para 5-14)

Leak check (para 5-10), evacuate (para 5-11), and charge (para 5-12) the refrigeration system

5-23. ACCUMULATOR REPLACEMENT.

This task covers: a Removal b. Installation

INITIAL SETUPMaterials/Parts.

Self Locking Nuts (2)
 17, Appendix G
 Insulation Tape
 10, Section II, Appendix E

Equipment Conditions:

Refrigeration system discharged (para 5-7) and
 purged (para 5-8).
 Left side door open.

a. Removal.

- (1) Remove insulation (1) as necessary.
- (2) De-braze two fittings (2) from accumulator (3) (para 5-9).
- (3) Remove self locking nut (4), flat washer (5), flat washer (6), and bolt (7). Discard self locking nut.

NOTE

Note flow direction prior to removal.

- (4) Remove self locking nut (8), flat washer (9) and accumulator (3). Discard self locking nut.

b. Installation**NOTE**

Be sure to observe flow direction noted during removal.

- (1) Install accumulator (3), flat washer (9), and new self locking nut (8).
- (2) Install flat washer (7), bolt (6), flat washer (5), and new self locking nut (4).
- (3) Braze two fittings (2) onto accumulator (3) (para 5-9).
- (4) Install insulation (1) and secure with insulation tape as necessary

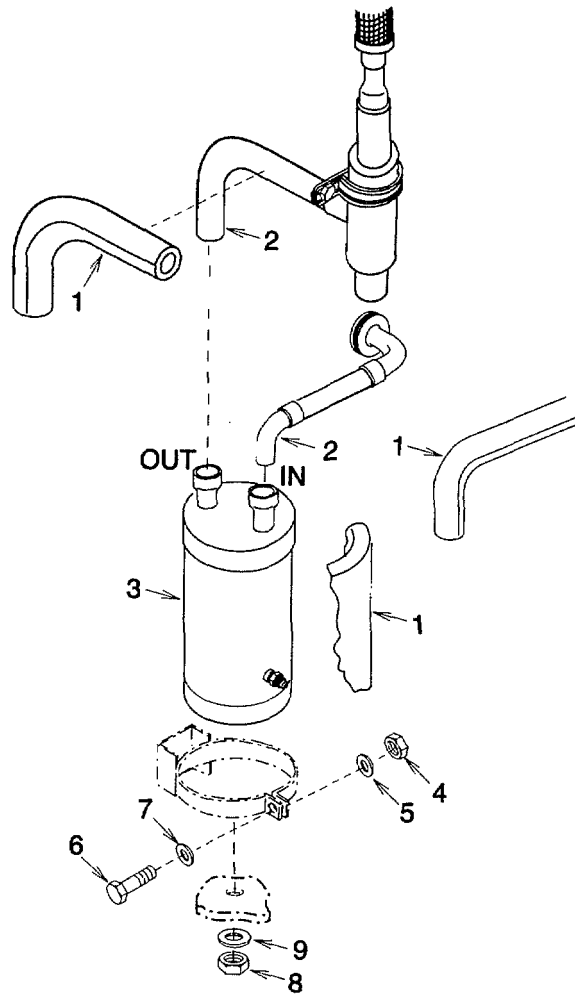

Figure 5-19. Accumulator

NOTE

FOLLOW-ON MAINTENANCE-

Close left side door.

Replace dehydrator (para 5-14)

Leak check (para 5-10), evacuate (para 5-11), and charge (para 5-12) the refrigeration system

5-24 SOLENOID VALVE L1 (LIQUID LINE) REPLACEMENT.

This task covers: a Removal b. Installation

INITIAL SETUP

Materials/Parts

Marker tags (2)
7, Appendix E

Equipment Conditions

Refrigeration system discharged (para 5-7)
Receiver removed (para 5-17)

a. Removal

- (1) Tag and disconnect wire leads (1)

NOTE

Solenoid coil mounting hardware is supplied with solenoid valve.

- (2) Remove screw (2), lock washer (3), data plate (4), and solenoid coil (5)

NOTE

Note flow direction prior to removal.

- (3) Loosen two flare nuts (6) and remove solenoid valve (7)

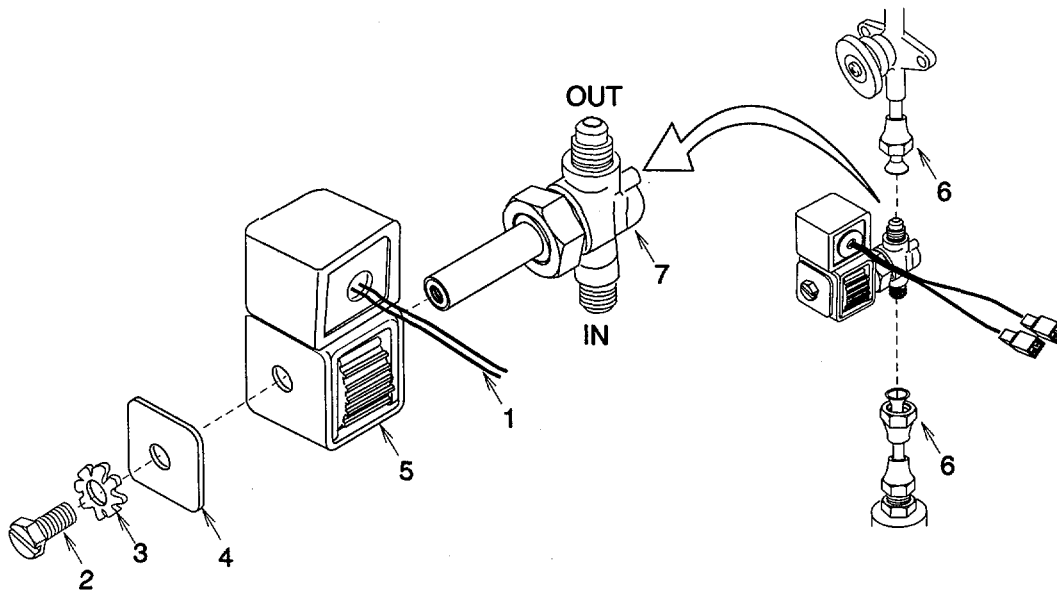

Figure 5-20. Solenoid Valve

5-24. SOLENOID VALVE L1 (LIQUID LINE) REPLACEMENT. - Continued

b. Installation.

NOTE

Be sure to observe flow direction noted during removal.

- (1) Install solenoid valve (7) and tighten two flare nuts (6).
- (2) Install solenoid coil (5), data plate (4), lock washer (3), and screw (2).
- (3) Using tags and wiring diagram (fig 2-4), connect wire leads (1). Remove tags.

NOTE

FOLLOW-ON MAINTENANCE.

Install receiver (para 5-17).

Replace dehydrator (para 5-14).

Leak check (para 5-10), evacuate (para 5-11), and charge (para 5-12) the refrigeration system.

5-25. SOLENOID VALVE L2 (DEFROST LINE) REPLACEMENT

This task covers: a Removal b. Installation

INITIAL SETUP

Materials/Parts:

Marker tags (2)
7, Appendix E

Equipment Conditions

Refrigeration system discharged (para 5-7)
Receiver removed (para 5-17).
Front bottom door open

a. Removal.

- (1) Tag and disconnect wire leads (1)

NOTE

Solenoid coil mounting hardware is supplied with solenoid valve

- (2) Remove screw (2), lock washer (3), data plate (4), and solenoid coil (5).

NOTE

Note flow direction prior to removal

- (3) Loosen two flare nuts (6) and remove solenoid valve (7).

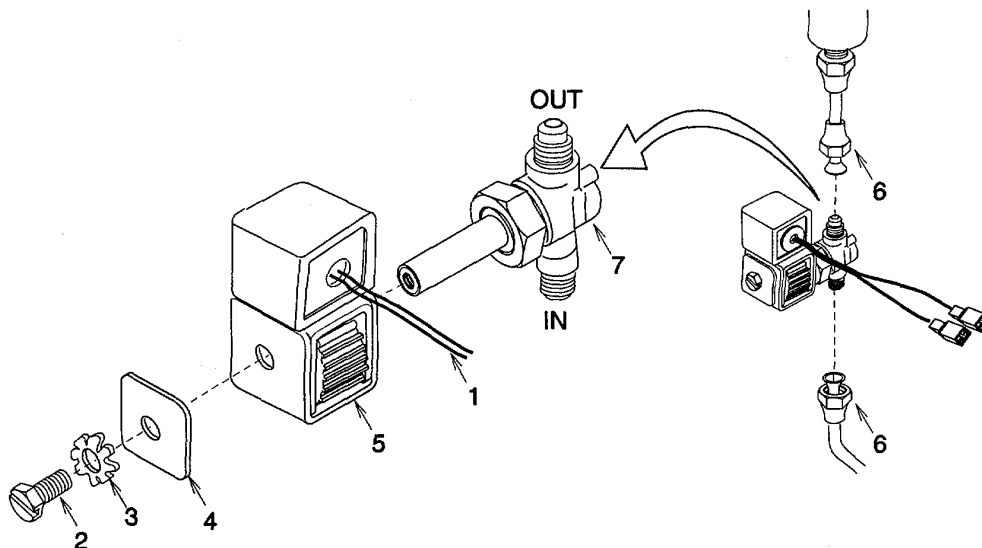

Figure 5-21. Solenoid Valve

5-25. SOLENOID VALVE L2 (DEFROST LINE) REPLACEMENT. - Continued

b. Installation.**NOTE**

Be sure to observe flow direction noted during removal.

- (1) Install solenoid valve (7) and tighten two flare nuts (6).
- (2) Install solenoid coil (5), data plate (4), lock washer (3), and screw (2).
- (3) Using tags and wiring diagram (fig. 2-4), connect wire leads (1) Remove tags.

NOTE**FOLLOW-ON MAINTENANCE:**

Install receiver (para 5-17).

Replace dehydrator (para 5-14).

Leak check (para 5-10), evacuate (para 5-11), and charge (para 5-12) the refrigeration system.

5-26. STOP VALVE (LIQUID LINE) REPLACEMENT.

This task covers: a Removal b. Installation

INITIAL SETUP

Materials/Parts:

Lock Washers (2)
1, Appendix G

Equipment Conditions:

Refrigeration system discharged (para 5-7) and
purged (para 5-8).
Receiver removed (para 5-17).

a. Removal.

- (1) De-braze two fittings (1) from stop valve (2) (para 5-9).
- (2) Remove two bolts (3), lock washers (4), spacers (5), and stop valve (2). Discard lock washers

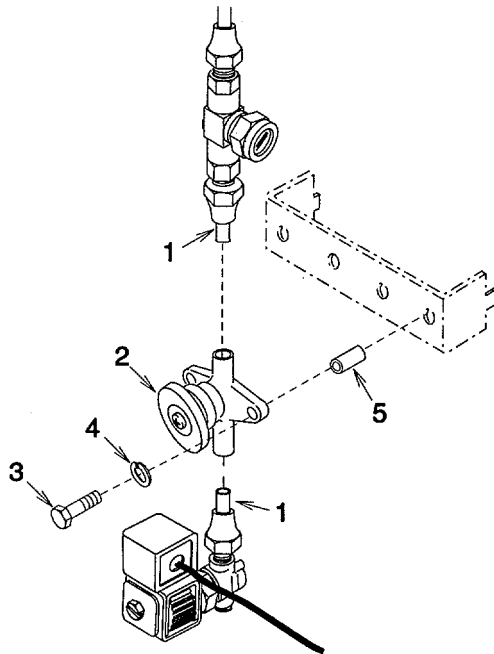

Figure 5-22. Stop Valve

5-26. STOP VALVE (LIQUID LINE) REPLACEMENT. - Continued

b. Installation.

(1) Install two spacers (5), two new lock washers (4), bolts (3) and stop valve (2).

CAUTION

Damage to valve can occur if not disassembled prior to brazing

(2) Braze two fittings (1) onto stop valve (2) (para 5-9)

NOTE

FOLLOW-ON MAINTENANCE:

Install receiver (para 5-17).

Replace dehydrator (para 5-14).

Leak check (para 5-10), evacuate (para 5-11), and charge (para 5-12) the refrigeration system

5-27. STOP VALVE (DEFROST LINE) REPLACEMENT.

This task covers: a Removal b. Installation

INITIAL SETUP

Materials/Parts.

Lock Washers (2)
1, Appendix G
Insulation Tape
10, Appendix E

Equipment Conditions

Refrigeration system discharged (para 5-7) and
purged (para 5-8).
Receiver removed (para 5-17).

a Removal

- (1) Remove insulation (1) as necessary.
- (2) De-braze two fittings (2) from stop valve (3) (para 5-9).
- (3) Remove two bolts (4), lock washers (5), and stop valve (3). Discard lock washers.

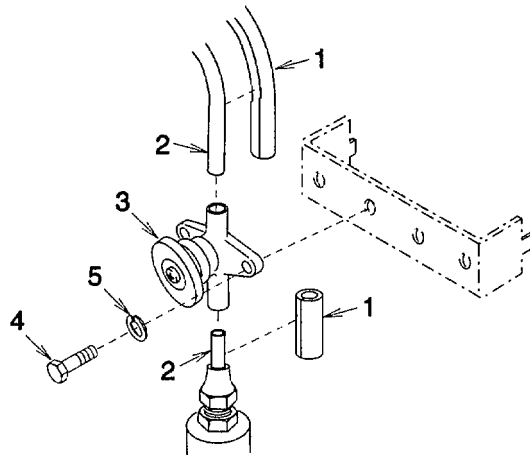

Figure 5-23. Stop Valve

5-27. STOP VALVE (DEFROST LINE) REPLACEMENT. - Continued

b. Installation.

- (1) Install stop valve (3), two new lock washers (5), and bolts (4).

CAUTION

Damage to valve can occur if not disassembled prior to brazing.

- (2) Braze two fittings (2) onto stop valve (3) (para 5-9)
- (3) Install insulation(1) and secure with insulation tape as necessary.

NOTE

FOLLOW-ON MAINTENANCE:

Install receiver (para 5-17)

Replace dehydrator (para 5-14).

Leak check (para 5-10), evacuate (para 5-11), and charge (para 5-12) the refrigeration system

5-28 SIGHT INDICATOR REPLACEMENT.

This task covers: a Removal b. Installation

INITIAL SETUP

Equipment Conditions

Refrigeration system discharged (para 5-7).
Receiver removed (para 5-17)

- a Removal Loosen two flare nuts (1) and remove sight indicator (2).

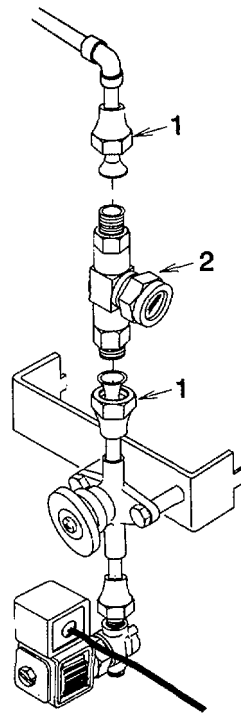

Figure 5-24. Sight Indicator

- b. Installation Install sight indicator (2), aligned facing the side door, and tighten two flare nuts (1).

NOTE

FOLLOW-ON MAINTENANCE

Install receiver (para 5-17).

Replace dehydrator (para 5-14).

Leak check (para 5-10), evacuate (para 5-11), and charge (para 5-12) the refrigeration system

5-29 DIFFERENTIAL OIL PRESSURE SWITCH S5 REPLACEMENT.

This task covers: a Removal b. Installation

INITIAL SETUPMaterials/Parts-

Lock Washers (2)
 1, Appendix G
 Self Locking Nuts (3)
 12, Appendix G
 Marker tags (6)
 7, Appendix E
 Tie Down Straps (as required)
 24, Appendix E

Equipment Conditions

Refrigeration system discharged (para 5-7)
 Both side doors open
 Top access panel removed (para 4-14)

a Removal.

- (1) Loosen screw (1) and remove cover (2)
- (2) Tag wire leads (3) Remove four screws (4) and pull leads out of differential oil pressure switch (5)
- (3) Remove three self locking nuts (6), bolts (7), and clamps (8). Discard self locking nuts
- (4) Remove tie down straps (9) as necessary
- (5) Tag each capillary tube (10) and loosen two flare nuts (11) from tees (12)
- (6) Remove grommet (13)
- (7) Remove two bolts (14), lock washers (15), and differential oil pressure switch (5). Discard lock washers.

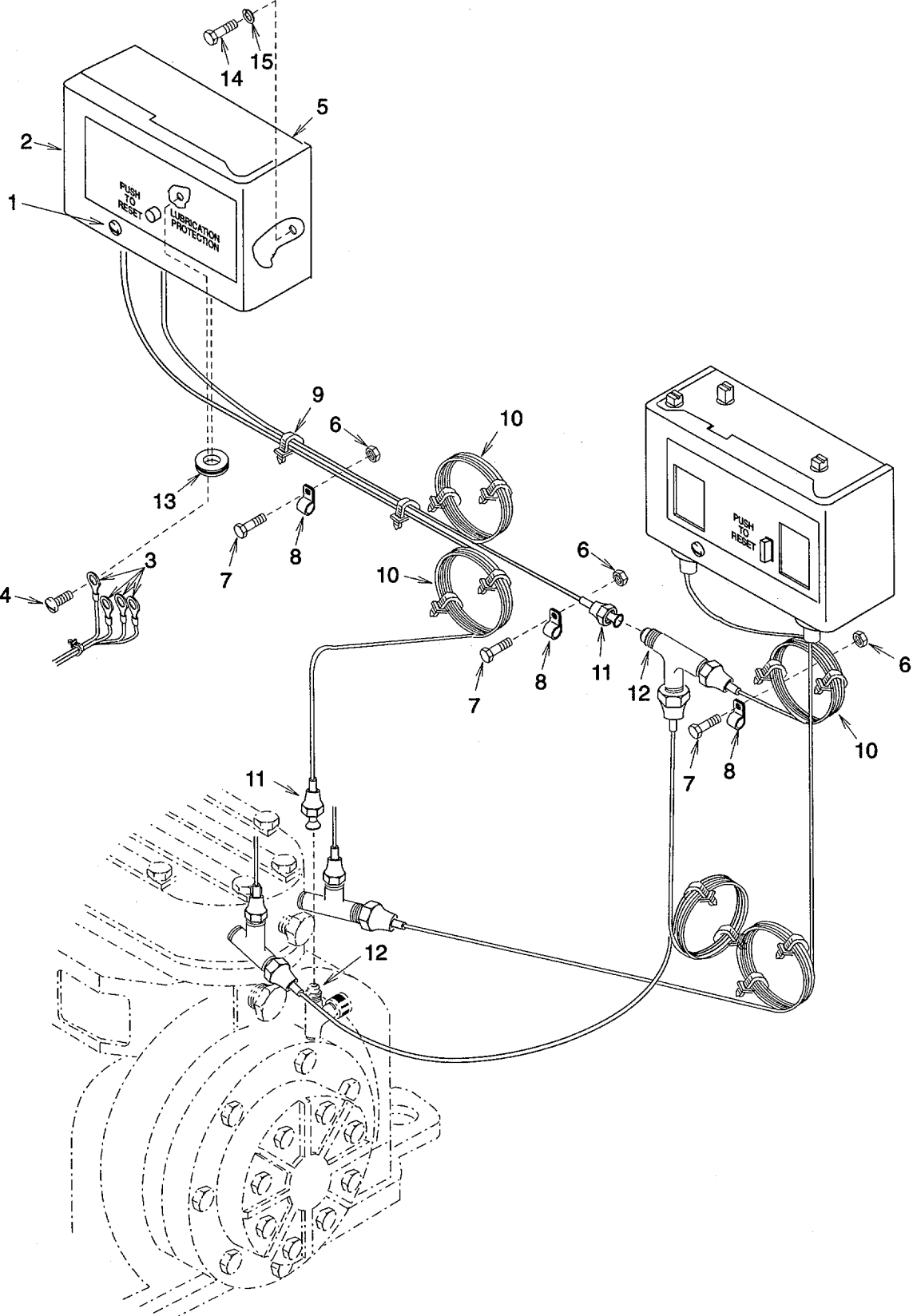

Figure 5-25. Differential Oil Pressure Switch S5

5-29. DIFFERENTIAL OIL PRESSURE SWITCH S5 REPLACEMENT. - Continuedb. Installation.

- (1) Loosen screw (1) and remove cover (2) from new differential oil pressure switch (5)

NOTE

Step 2 applies only to new differential oil pressure switch. A new differential oil pressure switch is configured with a jumper connected for operation at 115 Vac and must be removed for use with 208/230 Vac.

- (2) Remove and discard metal jumper from between terminals M and 2.
- (3) Install differential oil pressure switch (5), two new lock washers (15) and bolts (14).
- (4) Using tags on old differential pressure switch (5) for reference, neatly route capillary tubing (10) to tees (12) and carefully coil excess tubing as necessary.
- (5) Aline each capillary tube (10) to tee (12) and tighten two flare nuts (11).
- (6) Install three clamps (8) around capillary tubes (10). Install three bolts (7), and new self locking nuts (6).
- (7) Install grommet (13).
- (8) Push four wire leads (3) into differential oil pressure switch (5) and using tags and wiring diagram (fig. 2-4), install wire leads and screws (4). Remove tags.
- (9) Install cover (2) and tighten screw (1).
- (10) Install tie down straps (9) as necessary to secure capillary tubes (10).

NOTE**FOLLOW-ON MAINTENANCE'**

Close left side door.

Install top access panel (para 4-14).

Replace dehydrator (para 5-14).

Leak check (para 5-10), evacuate (para 5-11), and charge (para 5-12) the refrigeration system.

5-30. DUAL PRESSURE CONTROL SWITCH S2 REPLACEMENT.

This task covers: a Removal b. Installation

INITIAL SETUPMaterials/Parts:

Lock Washer (2)
1, Appendix G
Self Locking Nuts (2)
12, Appendix G
Marker tags (4)
7, Appendix E
Tie Down Straps (as required)
24, Appendix E

Equipment Conditions:

Refrigeration system discharged (para 5-7).
Right side door open.
Top access panel removed (para 4-14).

a. Removal.

- (1) Loosen screw (1) and remove cover (2).
- 2) Tag wire leads (3). Remove two screws (4) and pull leads out of dual pressure control switch (5).
- (3) Remove two self locking nuts (6), bolts (7), and clamps (8). Discard self locking nuts.
- (4) Remove tie down straps (9) as necessary.
- (5) Tag each capillary tube (10) and loosen two flare nuts (11) from tees (12).
- (6) Remove grommet (13).
- (7) Remove two bolts (14), lock washers (15), and dual pressure control switch (5).

b. Installation.

- (1) Loosen screw (1) and remove cover (2) from new dual pressure control switch (5)
- (2) Install dual pressure control switch (5), two bolts (14) and new lock washers (15).
- (3) Using tags on old dual pressure control switch (5) for reference, neatly route capillary tubing (10) to tees (12) and carefully coil excess tubing as necessary.
- (4) Aline each capillary tube (10) to tee (12) and tighten two flare nuts (11).
- (5) Install two clamps (8) around capillary tube (10). Install two bolts (7) and new self locking nuts (6).
- (6) Install grommet (13)
- (7) Push two wire leads (3) into dual pressure control switch (5) and using tags and wiring diagram (fig. 2-4), install wire leads and screws (4) Remove tags.

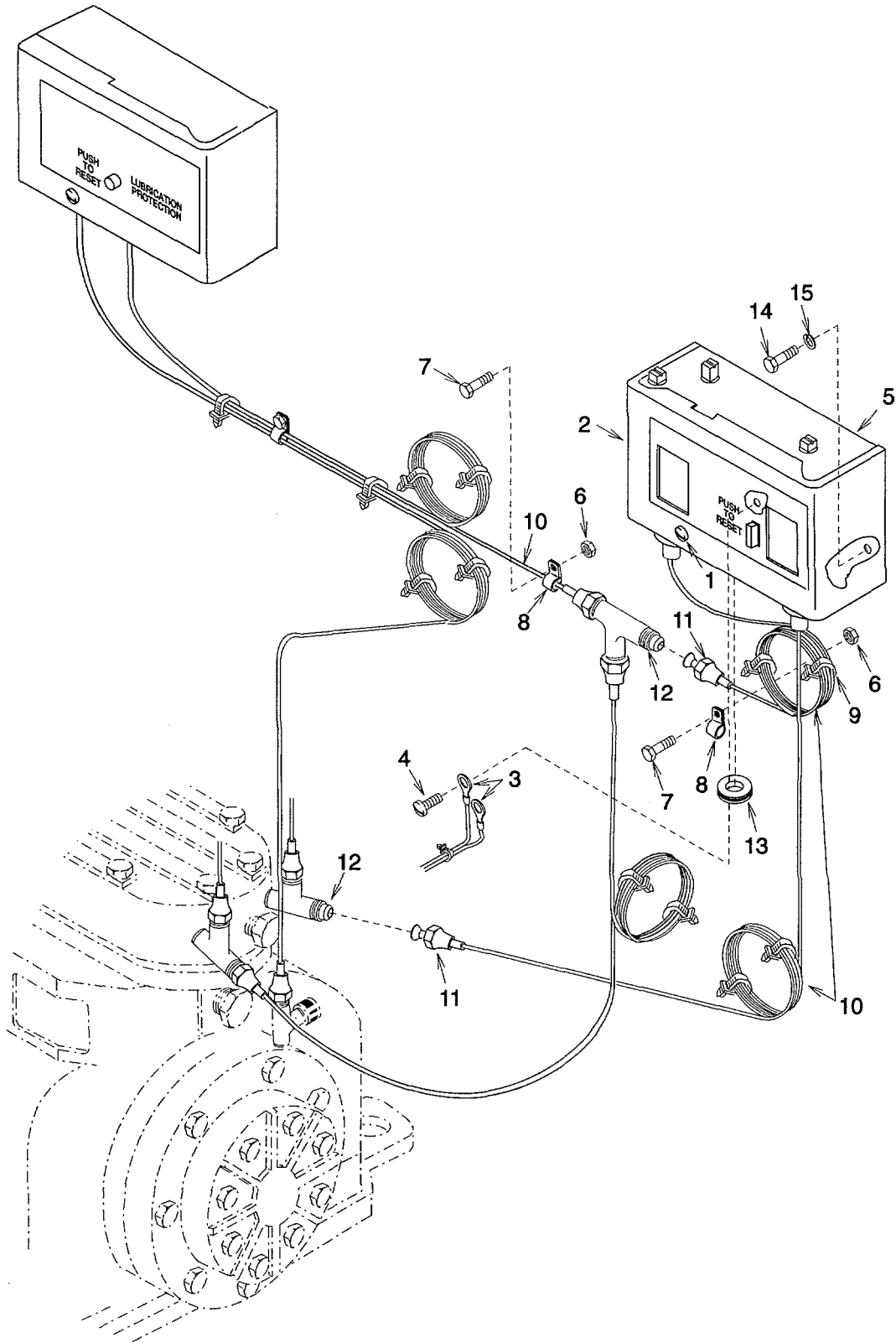

Figure 5-26. Dual Pressure Control Switch

- (8) Install cover (2) and tighten screw (1).
- (9) Install tie down straps (9) as necessary to secure capillary tubes (10)
- (10) Adjust HIGH PRESSURE CUTOUT to 305, low pressure CUT IN to 0, and low pressure CUTOUT to 15 IN. VAC.

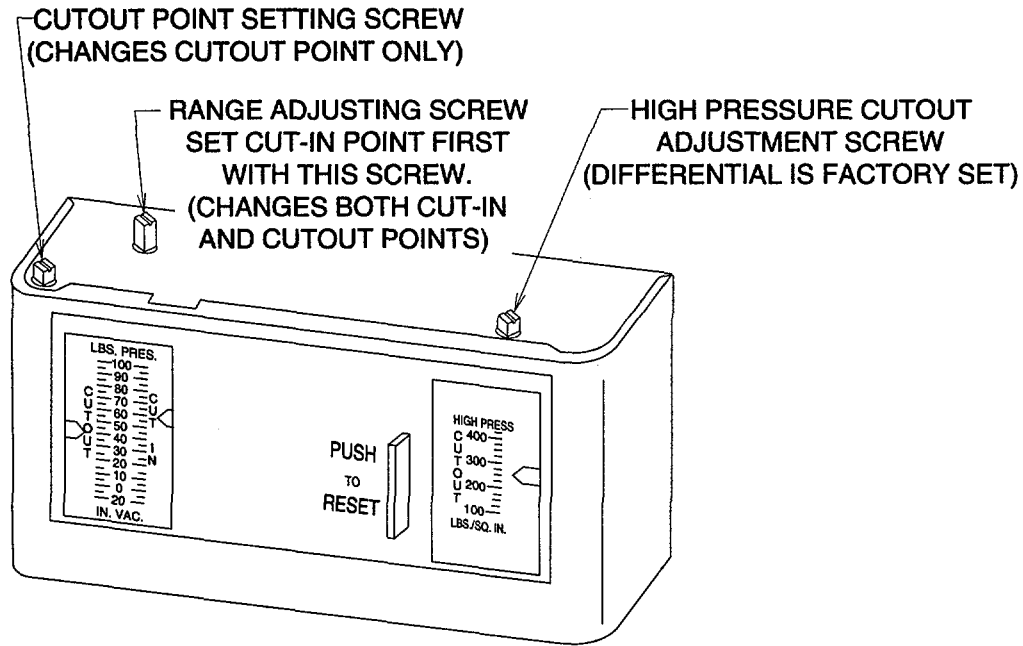

Figure 5-27. Dual Pressure Control Switch Settings

NOTE

FOLLOW-ON MAINTENANCE.
 Install top access panel (para 4-14)
 Replace dehydrator (para 5-14).
 Leak check (para 5-10), evacuate (para 5-11), and charge (para 5-12) the refrigeration system

5-31. COMPOUND GAGE (SUCTION PRESSURE) REPLACEMENT

This task covers: a Removal b. Installation

INITIAL SETUP

Materials/Parts

- Self Locking Nuts (3)
8, Appendix G
- Anti-Seize Tape
22, Appendix E

Equipment Conditions:

- Refrigeration system discharged (para 5-7).
- Control box cover raised and latched
- Left side door open.

a. Removal.

- (1) Loosen flare nut (1) and move copper tubing (2) over to one side being careful not to bend or kink tubing.
- (2) Remove coupling (3).
- (3) Remove three self locking nuts (4), screws (5) and compound gage (6) Discard self locking nuts.

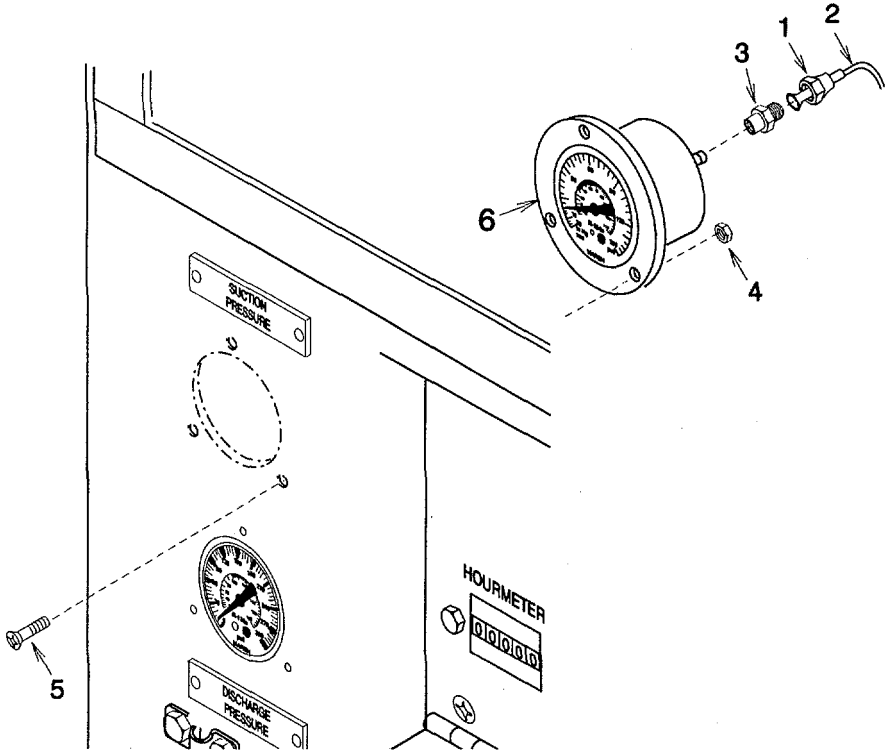

Figure 5-28. Compound Gage (Suction Pressure)

b. Installation.

- (1) Wrap anti-seize tape around compound gage (6) connector threads
- (2) Install compound gage (6), three screws (5), and new self locking nuts (4)
- (3) Install coupling (3).
- (4) Aline copper tubing (2) and connect flare nut (1) to coupling (3).

NOTE

FOLLOW-ON MAINTENANCE-

Close left side door.

Unlatch and close control box cover door.

Replace dehydrator (para 5-14).

Leak check (para 5-10), evacuate (para 5-11), and charge (para 5-12) the refrigeration system.

5-32 PRESSURE GAGE (DISCHARGE PRESSURE) REPLACEMENT

This task covers: a Removal b. Installation

INITIAL SETUP

Materials/Parts

Self Locking Nuts (3)
8, Appendix G
Anti-Seize Tape
22, Appendix E

Equipment Conditions:

Refrigeration system discharged (para 5-7).
Control box cover door raised and latched
Left side door open.

a Removal

- (1) Loosen flare nut (1) and move copper tubing (2) over to one side being careful not to bend or kink tubing.
- (2) Remove coupling (3).
- (3) Remove three self locking nuts (4), screws (5), and pressure gage (6). Discard self locking nuts

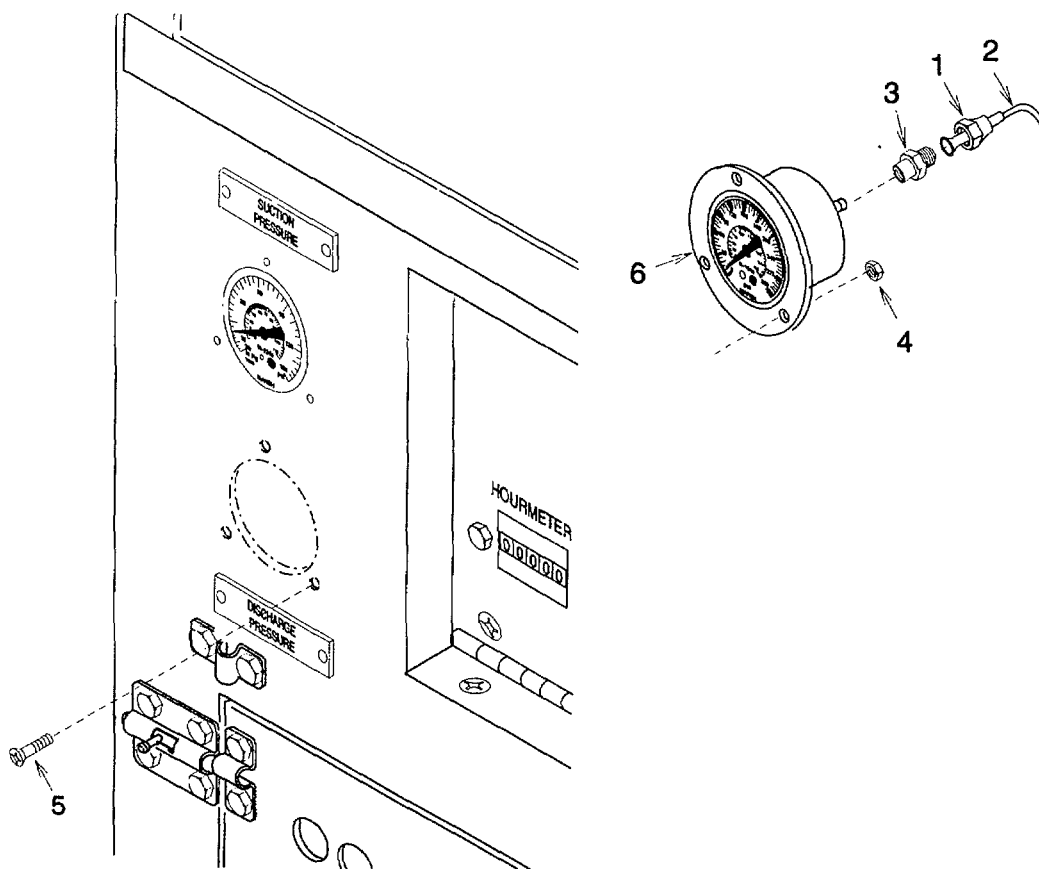

Figure 5-29. Pressure Gage (Discharge Pressure)

b Installation

- (1) Wrap anti-seize tape around pressure gage (6) connector threads.
- (2) Install pressure gage (6), three screws (5), and new self locking nuts (4).
- (3) Install coupling (3).
- (4) Aline copper tubing (2) and connect flare nut (1) to coupling (3)

NOTE

FOLLOW-ON MAINTENANCE'

Close left side door

Unlatch and close control box cover door

Replace dehydrator (para 5-14)

Leak check (para 5-10), evacuate (para 5-11), and charge (para 5-12) the refrigeration system.

5-33. HEAT EXCHANGER REPLACEMENT.

This task covers: a Removal b. Installation

INITIAL SETUP

Materials/ Parts.

Insulation Tape
10, Appendix E

Equipment Conditions

Refrigeration system discharged (para 5-7) and
purged (para 5-8)
Evaporator coil assembly removed (para 5-35)

a. Removal.

- (1) Remove insulation (1).

NOTE

Note flow direction prior to removal

- (2) De-braze four fittings (2) from heat exchanger (3) (para 5-9)

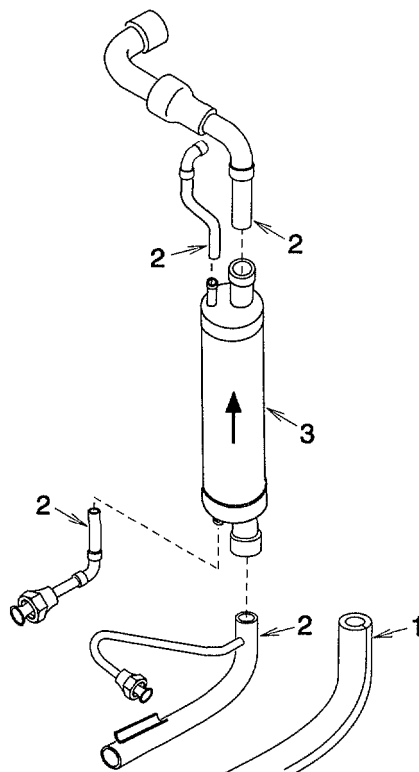

Figure 5-30. Heat Exchanger

b. Installation.

NOTE

Be sure to observe flow direction noted during removal.

- (1) Braze four fittings (2) onto heat exchanger (3) (para 5-9).
- (2) Install insulation (1) and secure using insulation tape.

NOTE

FOLLOW-ON MAINTENANCE:

Install evaporator coil assembly (para 5-35).

Replace dehydrator (para 5-14).

Leak check (para 5-10), evacuate (para 5-11), and charge (para 5-12) the refrigeration system.

Install access panel (para 4-15).

Install cover panel (para 4-16).

5-34. EXPANSION VALVE REPLACEMENT.

This task covers: a Removal b. Installation

INITIAL SETUP

Materials/Parts.

Self Locking Nut
14, Appendix G
Tie Down Straps (2)
28, Appendix E
Insulation Tape
10, Appendix E

Equipment Conditions

Refrigeration system discharged (para 5-7).
Access panel removed (para 4-15)

a. Removal.

- (1) Remove two screws (1) from expansion valve strap (2).
- (2) Remove self locking nut (3), screw (4), clamp (5), and expansion valve strap (2)
- (3) Remove insulation (6) as necessary to expose sensing bulb (7).
- (4) Remove and discard two tiedown straps (8).
- (5) Loosen three flare nuts (9) and remove expansion valve (10)

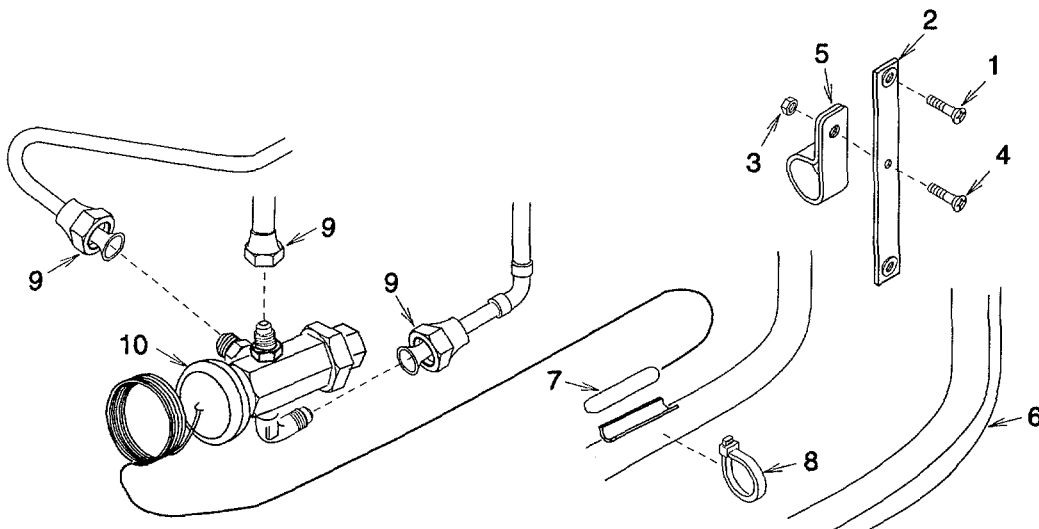

Figure 5-31. Expansion Valve

b. Installation

- (1) Install expansion valve (10) and tighten three flare nuts (9).
- (2) Install sensing bulb (7) and secure with two new tie down straps (8).
- (3) Slip clamp (5) over expansion valve body (10).
- (4) Install expansion valve strap (2), screw (4) and new self locking nut (3).
- (5) Install expansion valve strap (2) and two screws (1).

NOTE

FOLLOW-ON MAINTENANCE.

Replace dehydrator (para 5-14).

Leak check (para 5-10), evacuate (para 5-11), and charge (para 5-12) the refrigeration system

Install access panel (para 4-15).

5-35. EVAPORATOR COIL REPLACEMENT.

This task covers: a. Removal b. Installation

INITIAL SETUPMaterials/Parts.

Lock Washers (10)

1, Appendix G

Insulation Tape

10, Appendix E

Equipment Conditions:

Refrigeration system discharged (para 5-7) and purged (para 5-8).

Expansion valve removed (para 5-34)

Defrost termination thermostat removed (para 4-51).

Evaporator fan removed (para 4-43)

Fan belt removed (para 4-38).

General Safety Instructions'**WARNING**

High voltage and exposed rotating parts are used in the refrigeration unit. Personal injury can result if power is connected.

a. Removal.

- (1) Loosen two setscrews (1) on each evaporator and condenser flange bearing (2) collar.
- (2) Slide fan drive shaft (3) away from evaporator coil (4) just enough to allow evaporator shroud (5) to be removed with the coil.
- (3) Remove insulation (6)
- (4) Remove two clamps (7).
- (5) De-braze three fittings (8) (para 5-9).

WARNING

Coil fins are sharp and can cut hands or fingers. Wear gloves to prevent personal injury when handling coil.

- (6) Remove ten screws (9) and lift coil (4) and shroud (5) from frame (10).
- (7) Remove ten screws (11), lock washers (12), flat washers (13) and shroud (5). Discard lock washers.
- (8) Remove insulation (14).
- (9) De-braze three fittings (15) (para 5-9).

b. Installation.

WARNING

Coil fins are sharp and can cut hands or fingers. Wear gloves to prevent personal injury when handling cold

- (1) Install shroud (5) onto evaporator coil (4) using ten flat washers (13), new lock washers (12), and screws (11).
- (2) Braze three fittings (15) (para 5-9).
- (3) Install insulation (14) and secure using insulation tape as necessary.
- (4) Install evaporator coil (4) and shroud (5) into frame (10) Secure with ten screws (9)
- (5) Braze three fittings (8) (para 5-9).
- (6) Install two clamps (7) to secure heat exchanger (16).
- (7) Install insulation (6) and secure using insulation tape as necessary.
- (8) Slide fan drive shaft (3) back into place and tighten two setscrews (1) on each flange bearing (2) collar.

5-35. EVAPORATOR COIL REPLACEMENT - Continued

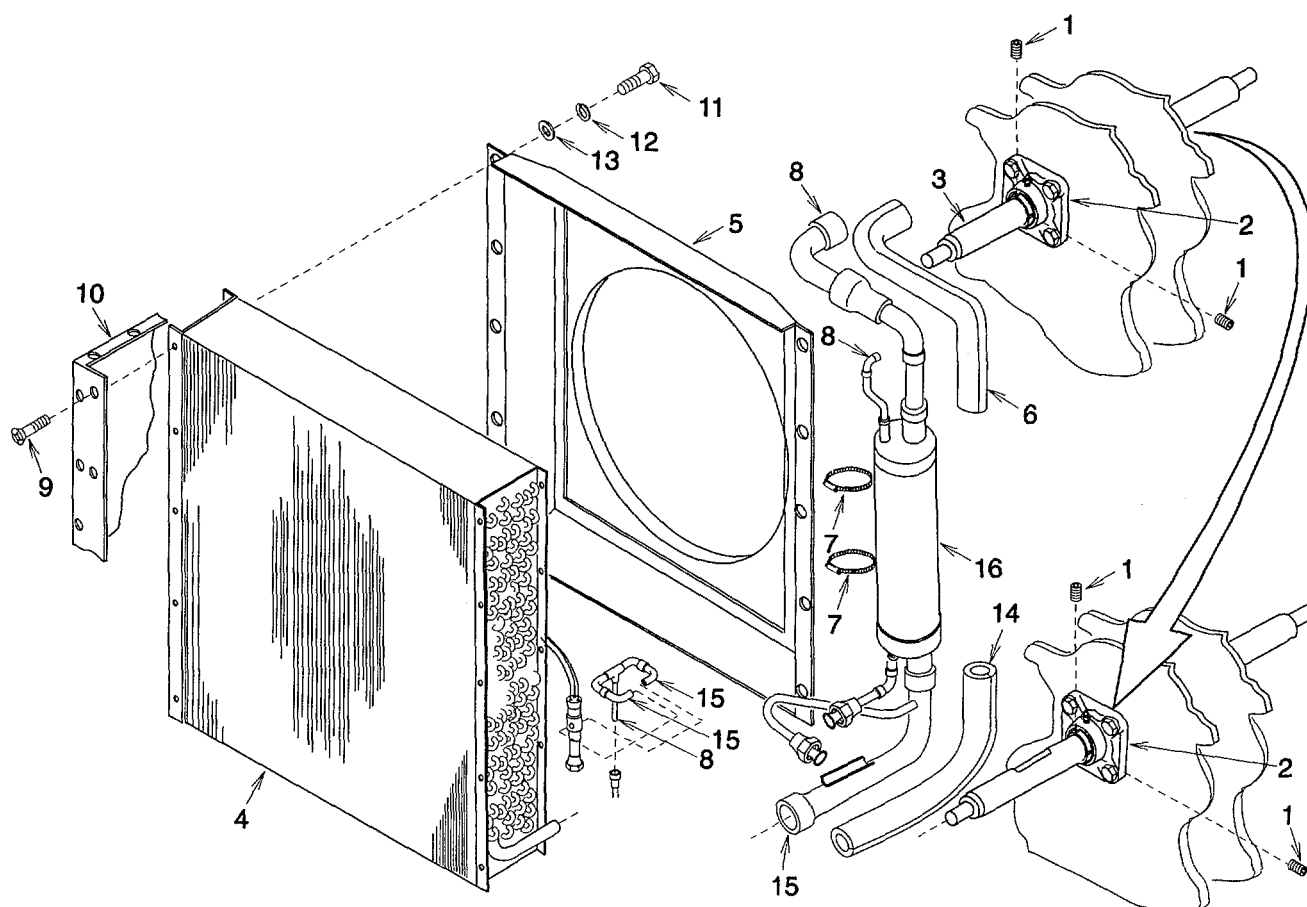

Figure 5-32. Evaporator Coil

NOTE

FOLLOW-ON MAINTENANCE

- Install defrost termination thermostat (para 4-51)
- Install evaporator fan (para 4-43)
- Install fan belt and adjust (para 4-38)
- Install expansion valve (para 5-34)
- Replace dehydrator (para 5-14)
- Leak check (para 5-10), evacuate (para 5-11), and charge (para 5-12) the refrigeration system
- Install access panel (para 4-15)
- Install cover panel (para 4-16)

5-36. COMPRESSOR B1 TESTING, REPAIR, AND REPLACEMENT.

This task covers: a. Testing b. Removal c. Disassembly d. Assembly e. Installation

INITIAL SETUP

Materials/Parts-

- Lock Washers (4)
28, Appendix G
- Locknut (4)
19, Appendix G
- Service Valve Gasket (Suction)
20, Appendix G
- Service Valve Gasket (Discharge)
21, Appendix G
- Cylinder Head Gasket
22, Appendix G
- Valve Plate Gasket
23, Appendix G
- Sight Glass
24, Appendix G
- Lock Washers (2)
29, Appendix G
- Fused Cluster Terminal
26, Appendix G
- Fused Cluster Seal
27, Appendix G
- Terminal Mounting Plate Gasket
4, Appendix G
- Oil Pump Gasket
18, Appendix G

Materials / Parts

- Seal
2, Appendix G
- Marker tags (15)
7, Appendix E
- Anti-Seize Tape
22, Appendix E
- Lubricating Oil
21, Appendix E

Equipment Conditions:

- Front top door open
- Both side doors open
- Top access panel removed (para 4-14)

General Safety Instructions.

WARNING

Compressor lubricating oil used in this refrigeration system is caustic. Wear gloves and a face protector or safety glasses in any situation where skin or eye contact is possible. If oil does contact skin, wash with soap and water.

a. Service.

- (1) Check oil level through sight glass (1). If oil level is not within best operating range, discharge refrigeration system (para 5-7).

CAUTION

Use only specified oil Compressor damage can result

NOTE

The oil fill plug cannot be purchased separately from the compressor. Care must be taken so it does not get lost or damaged.

- (2) Remove oil fill plug (2) then add or remove lubricating oil as necessary
- (3) Wrap anti-seize tape around oil fill plug (2) threads and install oil fill plug

5-36. COMPRESSOR B1 TESTING, REPAIR, AND REPLACEMENT. - Continued

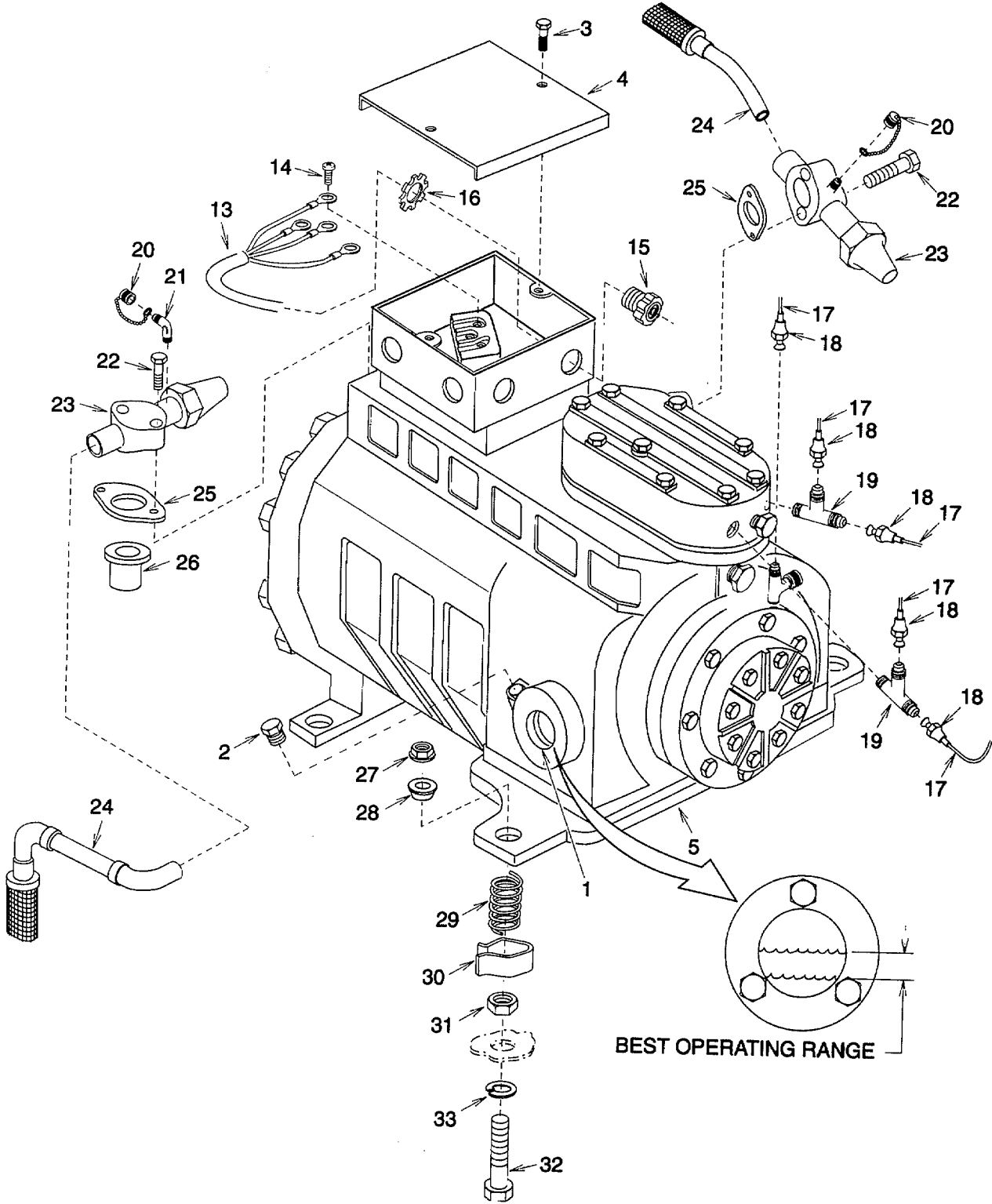

Figure 5-33. Compressor (Sheet 1 of 2)

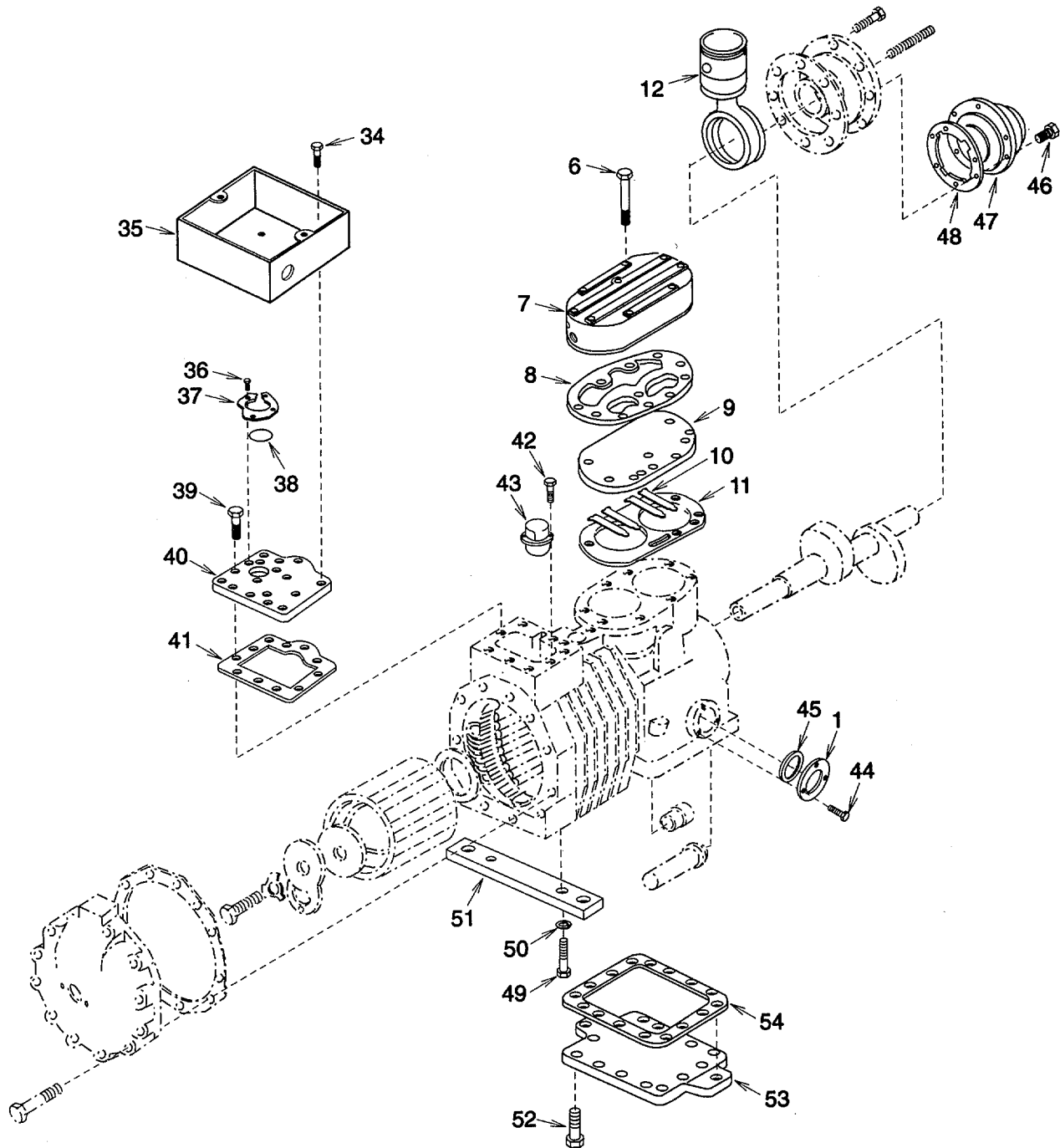

Figure 5-33. Compressor (Sheet 2 of 2)

5-36. COMPRESSOR B1 TESTING, REPAIR, AND REPLACEMENT - Continued

- (4) Replace dehydrator (para 5-14)
- (5) Leak check (para 5-10), evacuate (para 5-11), and charge (para 5-12) the refrigeration system.

b. Testing

- (1) Remove two screws (3) and cover (4)
- (2) Using multimeter set to measure continuity, check compressor (5) winding continuity between terminals 1 to 2, 1 to 3, and 3 to 2 Continuity should be indicated If continuity was not indicated, replace compressor.
- (3) Using multimeter set to measure continuity, check compressor (5) winding continuity between each terminal 1, 2, and 3 to compressor frame ground. No continuity should be indicated. If continuity was indicated, replace compressor.
- (4) Discharge refrigeration system (para 5-7).
- (5) Remove nine screws (6), cylinder head (7), cylinder head gasket (8), valve plate assembly (9), four reed valves (10) and valve plate gasket (11) Discard gaskets
- (6) Examine reed valves (10) for warpage and any other physical damage Replace valve plate assembly (9) if reed valves are damaged.
- (7) Examine compressor (5) cylinder walls for any scoring or excessive wear (groove at top of piston (12) travel Replace compressor if scored or excessively worn.
- (8) Press on top of highest piston (12). When pushed down, the higher piston should have some resistance and the lower piston should rise Repeat for other piston If either piston was loose and did not cause the other one to rise, replace piston and any other damaged components.
- (9) If no failure was indicated, remove any gasket material from all machined gasket surfaces and install new valve plate gasket (11), four reed valves (10), valve plate assembly (9), new cylinder head gasket (8), cylinder head (7), and nine screws (6)
- (10) Install cover (4) and two screws (3).
- (11) Replace dehydrator (para 5-14)
- (12) Leak check (para 5-10), evacuate (para 5-11), and charge (para 5-12) the refrigeration system.

c. Removal.**NOTE**

Remove only items necessary to access defective component(s)

- (1) Remove two screws (3) and cover (4)
- (2) Tag wire leads (13). Remove four screws (14) and pull wire leads out through strain relief cable bushing (15)
- (3) Remove ground strap (para 4-52)

- (4) Remove conduit locknut (16) and strain relief cable bushing (15).
- (5) Discharge refrigeration system (para 5-7)
- (6) Tag capillary tubes (17) and loosen five flare nuts (18) from tees (19) and carefully pull tubes away from tees being careful not to bend or kink tubes.
- (7) Remove two tees (19).
- (8) Remove two caps and chains (20) and one elbow (21).
- (9) Remove four screws (22) Pull two service valves (23) away from compressor (5) being careful not to bend or kink tubing (24). Remove two service valve gaskets (25) and suction screen (26) Discard gaskets.

WARNING

Compressor weight exceeds 240 lb (109 kg). Use appropriate lifting device to avoid personal injury.

- (10) Remove four locknuts (27), mounting spacers (28), and compressor (5). Discard locknuts.
- (11) Remove four mounting springs (29) and shipping brackets (30)
- (12) Remove four nuts (31), screws (32), lock washers, (33). Discard lock washers.
- (13) De-braze two service valves (23) from tubing (24) (para 5-9).

d. Disassembly.

NOTE

Disassemble only as necessary to replace defective component(s).

- (1) Remove four screws (6), cylinder head (7), cylinder head gasket (8), valve plate assembly (9), four reed valves (10), and valve plate gasket (11). Discard gaskets
- (2) Remove four screws (34) and terminal box (35).
- (3) Remove three screws (36), fused cluster terminal (37), and fused cluster seal (38) Discard fused cluster terminal and seal
- (4) Remove 10 screws (39), terminal plate (40), and terminal mounting plate gasket (41) Discard gasket.
- (5) Remove two screws (42) and protector (43)
- (6) Remove three screws (44), sight glass (1), and seal (45). Discard seal.
- (7) Remove six screws (46), oil pump (47), and oil pump gasket (48). Discard gasket.
- (8) Remove two screws (49), lock washers (50), and mounting foot plate (51).
- (9) Remove 17 screws (52), bottom plate (53), and bottom plate gasket (54). Discard gasket.

5-36. COMPRESSOR B1 TESTING, REPAIR, AND REPLACEMENT. - Continuede. Assembly.

- (1) Remove any gasket material from all machined gasket surfaces.
- (2) Install new bottom plate gasket (54), bottom plate (53), and 17 screws (52).
- (3) Install mounting foot plate (51), two new lock washers (50), and screws (49).
- (4) Install new oil pump gasket (48), oil pump (47), and six screws (46).
- (5) Install new seal (45), sight glass (1) and three screws (44).
- (6) Install protector (43) and two screws (42).
- (7) Install new terminal mounting plate gasket (41), terminal plate (40), and 10 screws (39).
- (8) Install new fused cluster seal (38), new fused cluster terminal (37), and three screws (36).
- (9) Install terminal box (35) and four screws (34).
- (10) Install new valve plate gasket (11), four reed valves (10), valve plate assembly (9), new cylinder head gasket (8), cylinder head (7), and four screws (6).
- (11) Check compressor lubricating oil level at sight glass (1). Level should be at mid-point of sight glass. Add or remove oil as necessary.
 - (a) Remove plug (2)
 - (b) Add or remove oil as necessary
 - (c) Wrap anti-seize tape around plug (2) threads
 - (d) Install plug (2).

f. Installation

- (1) Install two service valves (23) onto tubing (24) with mounting surfaces at right angles to each other and braze connection (para 5-9).
- (2) Install four new lock washers (33), screws (32), and nuts (31).
- (3) Install four mounting springs (29) and shipping brackets (30).

WARNING

Compressor weight exceeds 240 lb (109 kg) Use appropriate lifting device to avoid personal injury.

- (4) Install compressor (5), four mounting spacers (28), and new locknuts (27).
- (5) Install suction screen (26), two new service valve gaskets (25), service valves (23), and four screws (22)

- (6) Wrap anti-seize tape around threaded end of elbow (21) Install elbow and two cap and chains (20)
- (7) Wrap anti-seize tape around threaded end of each tee (19) and install two tees
- (8) Align capillary tubes (17) with tees (19) using tags as reference being careful not to bend or kink tubes. Tighten six flare nuts (18)
- (9) Install strain relief cable bushing (15) and conduit locknut (16)
- (10) Push wire leads (13) through strain relief cable bushing (15). Install wire leads, using tags and wiring diagram (fig 1-4), and four screws (14). Remove tags.
- (11) Install cover (4) and two screws (3).
- (12) Install ground strap (para 4-52).
- (13) Replace dehydrator (para 5-14)
- (14) Leak check (para 5-10), evacuate (para 5-11), and charge (para 5-12) the refrigeration system

NOTE

FOLLOW-ON MAINTENANCE
Close both side doors
Close front top door.
Install top access panel (para 4-14).

5-37. TUBING AND FITTINGS TESTING, REPAIR, AND REPLACEMENT.

This task covers: a. Testing b. Removal c. Installation

INITIAL SETUPMaterials/Parts:

Silicone RTV
20, Appendix E
Insulation Tape

General Safety Instructions,**WARNING**

High voltage and rotating parts are used in the refrigeration unit. Personal injury can result if power is connected.

Equipment Conditions:

Doors, panels, guards open/removed as necessary.

- a. Testing. Leak test the tubing and fittings (para 5-10)

NOTE

Repair consists of replacing damaged or leaking tubing and/or fittings.

- b. Removal.

- (1) Discharge (para 5-7) the refrigeration system
- (2) If a flare connection was leaking, loosen flare nut and cut the damaged flare off the tubing end
- (3) Remove insulation as necessary.
- (4) Purge (para 5-8) the refrigeration system and de-braze (para 5-9) any fitting or tubing that was leaking or was too short to flare.
- (5) Remove any silicone RTV remaining in evaporator frame grommets.

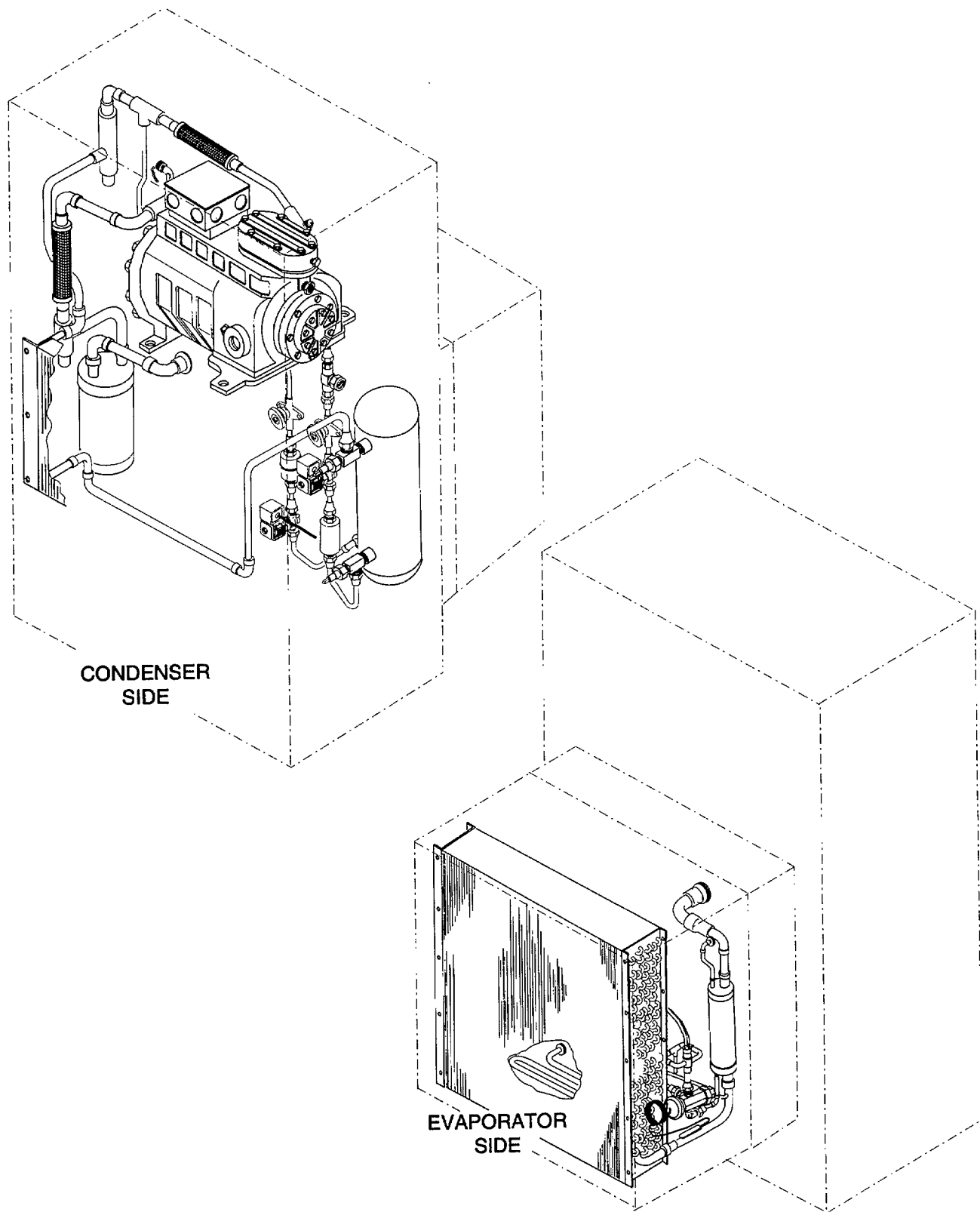

Figure 5-34. Tubing And Fittings

5-37. TUBING AND FITTINGS TESTING, REPAIR, AND REPLACEMENT. - Continued

c. Installation.

- (1) Purge (para 5-8) the refrigeration system and braze (para 5-9) any loose tubing or fitting connections.
- (2) Flare tubing end where damaged flare was removed or on end of new tube if it was too short to flare.
- (3) Replace dehydrator (para 5-14).
- (4) Leak check (para 5-10), evacuate (para 5-11), and charge (para 5-12) the refrigeration system.
- (5) Apply silicone RTV into evaporator frame grommets to seal evaporator enclosure.
- (6) Install insulation If removed and secure with insulation tape as necessary.

NOTE

FOLLOW-ON MAINTENANCE.
Close/install any doors, panels, guards removed.

5-38. PLATES (DATA) REPLACEMENT.

This task covers: a. Removal b. Installation

INITIAL SETUPEquipment Conditions

Refrigeration unit shut down (para 2-7) and power disconnected.

General Safety Instructions**WARNING**

High voltage and rotating parts are used in the refrigeration unit. Personal injury can result if power is connected

- a. Removal.
- (1) Drill through rivets using drill bit slightly smaller than rivet diameter.
 - (2) Remove plate and any remaining rivet material.
- b. Installation. Install new plate and rivets as required.

NOTE

FOLLOW-ON MAINTENANCE:
Connect power and put unit back into service

5-39. LEFT AND RIGHT SIDE DOOR REPLACEMENT.

This task covers: a. Removal b. Installation

INITIAL SETUPMaterials/Parts

Lock Washers (8)
1, Appendix G
Rivets (48)
26, Appendix E

Equipment Conditions

Refrigeration unit shut down (para 2-7) and power disconnected

General Safety Instructions**WARNING**

High voltage and exposed rotating parts are used in the refrigeration unit. Personal injury can result if power is connected

NOTE

Quantities given are for each door.

a. Removal.

- (1) Remove four bumpers (1).
- (2) Remove four bolts (2), lock washers (3), and two barrel bolt clips (4). Discard lock washers.
- (3) Using drill bit slightly smaller than rivet diameter, drill through twelve rivets (5) and remove door (6)
- (4) Drill through twelve rivets (7) and remove two hinges (8).

b. Installation.

- (1) Install two hinges (8) onto door (6) and secure with twelve rivets (7)
- (2) Install door (6) and secure with twelve rivets (5)
- (3) Install two barrel bolt clips (4) and secure with four new lock washers (3) and bolts (2).
- (4) Install four bumpers (1).

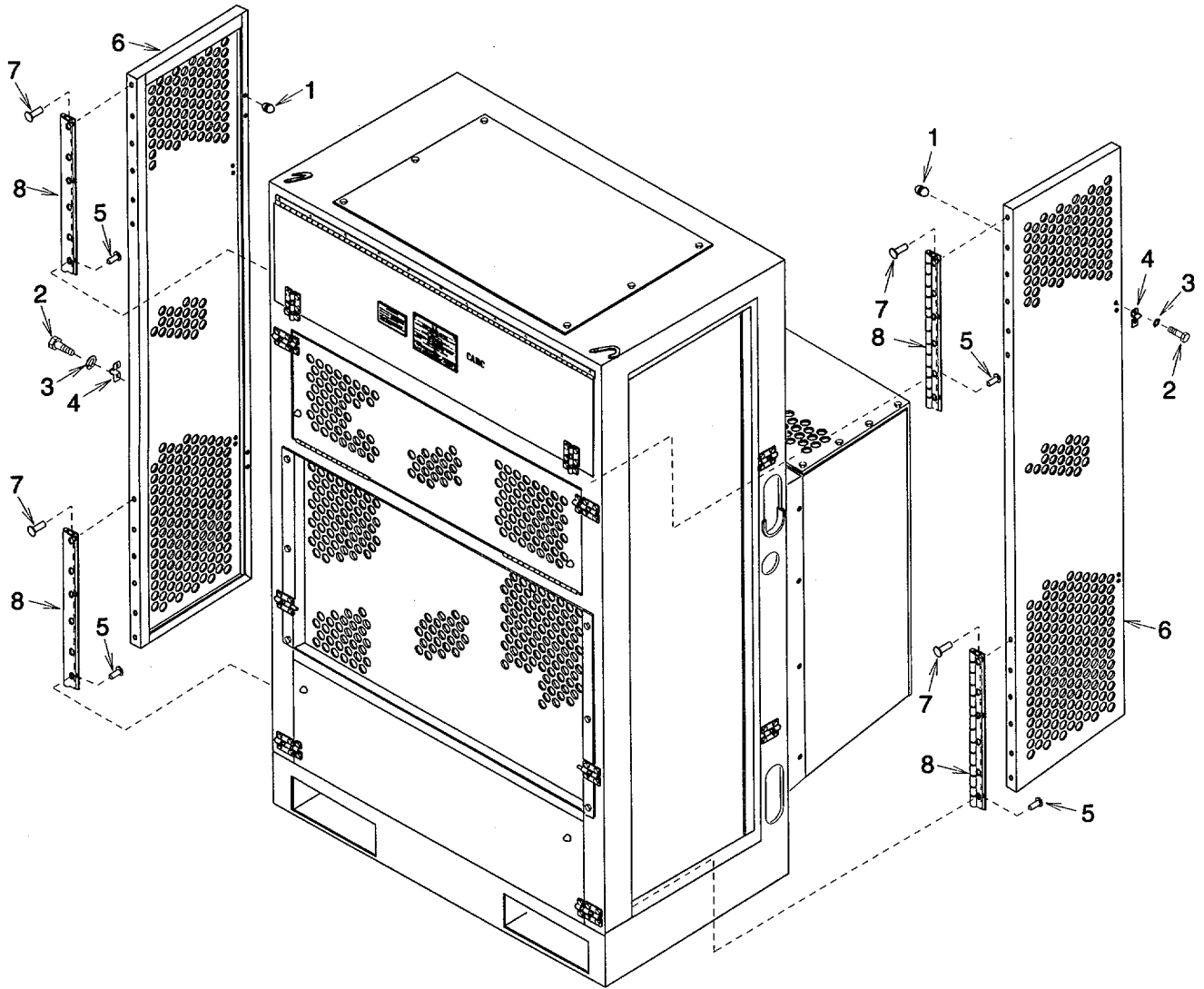

Figure 5-35. Left and Right Side Doors

NOTE

FOLLOW-ON MAINTENANCE
 Connect power and put unit back in service

5-40. FRONT BOTTOM DOOR REPLACEMENT

This task covers: a. Removal b. Installation

INITIAL SETUP

Materials/Parts.

Lock washers (4)

1, Appendix G

Rivets (16)

26, Appendix E

Equipment Conditions.

Refrigeration unit shut down (para 2-7) and power disconnected.

a. Removal.

- (1) Remove six bumpers (1).
- (2) Remove four bolts (2), lock washers (3), and two barrel bolt clips (4). Discard lock washers.
- (3) Using drill bit slightly smaller than rivet diameter drill through eight rivets (5) and remove door (6)
- (4) Drill through eight rivets (7) and remove two hinges (8)

b. Installation.

- (1) Install two hinges (8) onto door (6) and secure using eight rivets (7).
- (2) Install door (6) using eight rivets (5).
- (2) Install two barrel bolt clips (4), four new lock washers (3), and bolts (2).
- (3) Install six bumpers (1).

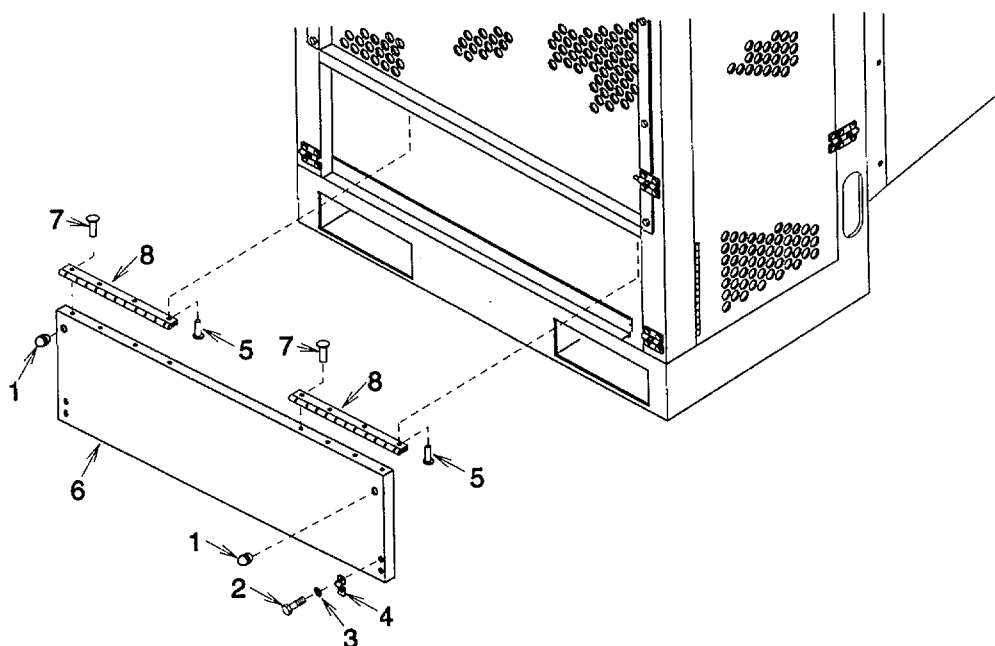

Figure 5-36. Front Bottom Door

NOTE

FOLLOW ON MAINTENANCE.
Close door and put unit back into service.

5-41. FRONT TOP DOOR REPLACEMENT

This task covers: a. Removal b. Installation

INITIAL SETUP

Materials/Parts

Rivets (16)
26, Appendix E
Lock Washers (4)
1, Appendix G

Equipment Conditions:

Refrigeration unit shut down (para 2-7) and power disconnected.

a. Removal.

- (1) Remove six bumpers (1).
- (2) Remove four bolts (2), lock washers (3), and two barrel bolt clips (4) Discard lock washers
- (3) Using drill bit slightly smaller than rivet diameter drill through eight rivets (5) and remove door (6)
- (4) Drill through eight rivets (7) and remove two hinges (8)

b. Installation

- (1) Install two hinges (8) onto door (6) and secure using eight rivets (7)
- (2) Install door (6) using eight rivets (5).
- (2) Install two barrel bolt clips (4), four new lock washers (3), and bolts (2)
- (3) Install six bumpers (1)

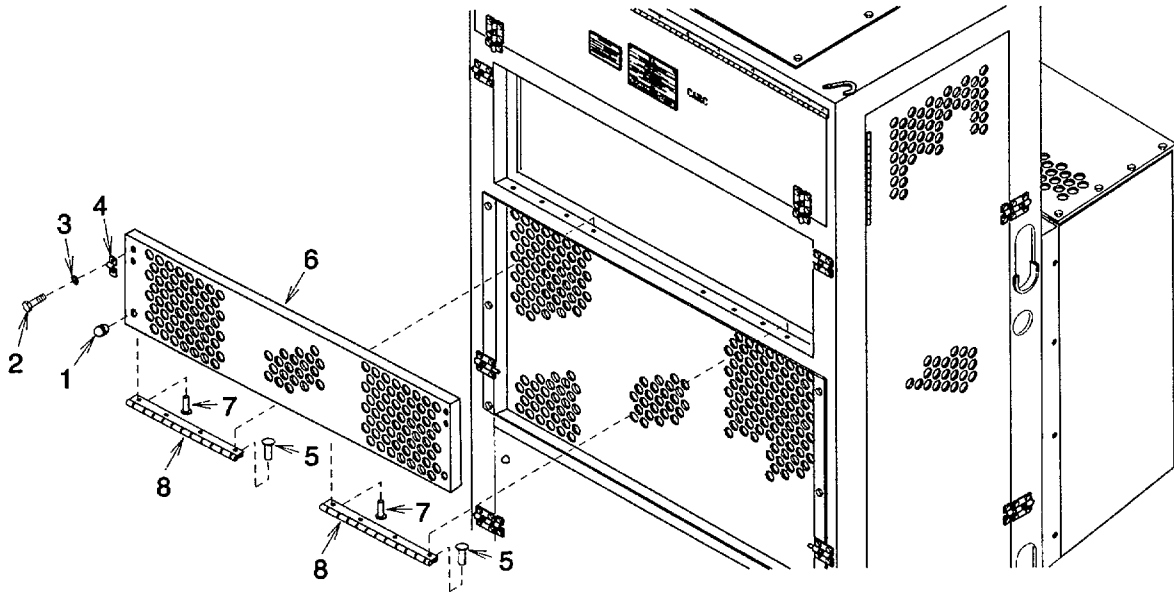

Figure 5-37. Front Top Door

NOTE

FOLLOW-ON MAINTENANCE
Connect power and put unit back into service

542. CONTROL BOX COVER REPAIR AND REPLACEMENT

This task covers: a. Removal b. Repair c. Installation

INITIAL SETUPMaterials / Parts

Rivet (8)
29, Appendix E
Rivet (11)
27, Appendix E
Adhesive, General Purpose
14, Appendix E
Wiping Rag
3, Acetone E
18, Appendix E
Methyl- Ethyl Ketone
19, Methyl Ethyl Ketone
Gaskets (2)
3, Figure F-5, Appendix F
Gaskets
Figure F-28, Appendix F
Gaskets
4, Figure F-5, Appendix F

Equipment Conditions

Refrigeration unit shut down (para 2-7) and power disconnected.

General Safety Instructions:**WARNING**

Acetone and methyl-ethyl ketone (MEK) are flammable and their vapors can be explosive. Repeated or prolonged skin contact or inhalation of vapors can be toxic. Use in a well ventilated area, wear gloves, and keep away from sparks or flame

a. Removal.

- (1) Using drill bit slightly smaller than rivet diameter, drill through eleven rivets (1) and remove control box cover (2).
- (2) Using drill bit slightly smaller than rivet diameter, drill through eight rivets (3) and remove data plates (4) and (5)

b. Repair.

- (1) Remove as much old gasket material (6), (7), or (8) as possible by pulling or scraping it away from the control box cover (2)
- (2) Soften and remove old adhesive and gasket (6), (7), or (8) residue, using acetone or methyl-ethyl ketone (MEK) and a stiff brush.
- (3) Be sure that the attaching surface of the control box cover (2) is clean and free of paint and old adhesive material.
- (4) Coat the mating surfaces of the control box cover (2) and gasket (6), (7), or (8) with adhesive. Let both surfaces air dry until adhesive is tacky, but will not stick to fingers.
- (5) Starting with an end, carefully press gasket (6), (7), or (8) onto the control box cover (2). Press firmly overall to ensure complete contact.

c. Installation.

- (1) Install data plates (4) and (5) and secure using eight rivets (3)
- (2) Install control box cover (2) and secure using eleven rivets (1)

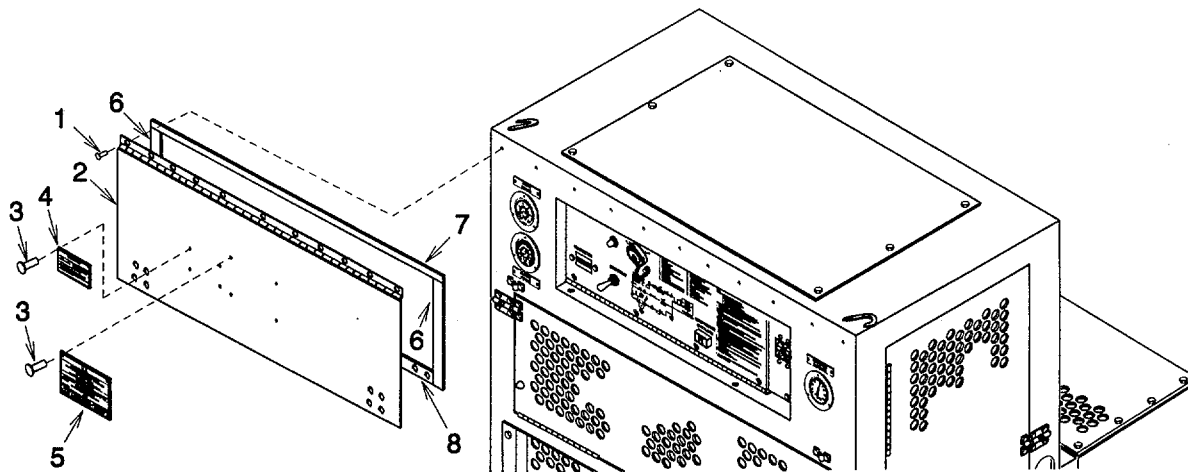

Figure 5-38. Control Box Cover

5-43. FRAME REPAIR

This task covers. Repair

INITIAL SETUPEquipment Conditions

Refrigeration unit shut down (para 2-7) and power disconnected

General Safety Instructions**WARNING**

High voltage and rotating parts are used in the refrigeration unit. Personal injury can result if power is connected.

Repair**NOTE**

Repair to condenser frame at this maintenance level is limited to replacement of any damaged rivets or blind rivet nuts

- (1) Drill through rivet or blind rivet nut using drill bit slightly smaller than rivet diameter
- (2) Remove any remaining rivet material
- (3) Install new rivet or blind rivet nut as required

CHAPTER 6

GENERAL SUPPORT MAINTENANCE INSTRUCTIONS

6-1. GENERAL

The only item authorized by the Maintenance Allocation Chart (MAC) to the general support maintenance level is welding repair to the condenser frame. However, general support maintenance may be called upon to perform any or all of the MAC items listed for unit and direct support maintenance for rehabilitation or overhaul of the refrigeration unit.

6-2. CONDENSER FRAME REPAIR

This task covers: Repair

INITIAL SETUPEquipment Conditions

Refrigeration unit shut down (para 2-7) and power disconnected

General Safety Instructions**WARNING**

High voltage and rotating parts are used in the refrigeration unit. Personal injury can result if power is connected.

Repair

- (1) Disassemble refrigeration unit as necessary and make repairs as indicated
- (2) Repair any minor sheet metal dents and bent edges by straightening using common sheet metal repair procedures
- (3) Weld any cracks or breaks in frame members or welds per MIL-B-7883
- (4) Touch-up any painted surfaces per TM 43-0139.
- (5) Assemble refrigeration unit as necessary to return to service

APPENDIX A

REFERENCES

A-1. SCOPE

This appendix list all forms, field manuals, and technical manuals referenced m this manual.

A-2. FORMS.

Recommended Changes to Publications DA Form 2028

Recommended Changes to Equipment Technical Manuals DA Form 2028-2

Product Quality Deficiency Report Standard Form 368

A-3. FIELD MANUALS.

NBC Contamination Avoidance FM 3-3

NBC Protection FM 3-4

NBC Decontamination FM 3-5

A-4. TECHNICAL MANUALS.

Destruction of Army Material to Prevent Enemy Use TM 750-244-3

Unit, Direct Support, and General Support Maintenance
Repair Parts and Special Tools List TM 9-4110-254-24P

A-5. MISCELLANEOUS PUBLICATIONS.

Army Logistics Readiness and Sustainability AR 700-138

Army Maintenance Management System (TAMMS)..... DA Pam 738-750

Expendable Items
(Except Medical Class V, Repair Parts and Heraldic Items) CTA 50-970

Army Medical Department Expendable/Durable Items CTA 8-100

Methods of Preservation MIL-P-116

Crates, Wood, Open And Covered MIL-C-52950

A-6. WARRANTY TECHNICAL BULLETIN.

Refrigeration Unit, Mechanical, Electric 5K BTU Model F5000RE TB 9-4110-254-24

APPENDIX B

MAINTENANCE ALLOCATION CHART

SECTION I INTRODUCTION

B-1. THE ARMY MAINTENANCE SYSTEM MAC

a. This introduction (Section I) provides a general explanation of all maintenance and repair functions authorized at various maintenance levels under the standard Army Maintenance System concept.

b. The Maintenance Allocation Chart (MAC) in Section II designates overall authority and responsibility for the performance of maintenance functions on the refrigeration unit. The application of the maintenance functions to the end item or component will be consistent with the capacities and capabilities of the designated maintenance levels, which are shown on the MAC in column (4) as.

Unit - Includes two subcolumns, C (operator/crew) and O (unit) maintenance.

Direct Support - Includes an F subcolumn

General support - Includes an H subcolumn.

Depot - Includes a D subcolumn

c. Section III lists the tools and test equipment (both special tools and common tool sets) required for each maintenance function as referenced from Section II.

d. Section IV contains supplemental instructions and explanatory notes for a particular maintenance function.

B-2. MAINTENANCE FUNCTIONS.

Maintenance functions will be limited to and defined as follows-

a. Inspect. To determine the serviceability of an item by comparing its physical, mechanical and/or electrical characteristics with established standards through examination (e g, by sight, sound, or feel)

b. Test. To verify serviceability by measuring the mechanical, pneumatic, hydraulic, or electrical characteristics of an item and comparing those characteristics with prescribed standards.

c. Service. Operations required periodically to keep an item in proper operating condition, e g, to clean (includes decontaminate when required), to preserve, to drain, to paint, or to replenish fuel, lubricants, chemical fluids, or gases.

d. Adjust. To maintain or regulate, within prescribed limits, by bringing into proper position, or by setting the operating characteristics to specified parameters.

e. Aline. To adjust specified variable elements of an item to bring about optimum or desired performance

B-2. MAINTENANCE FUNCTIONS. -Continued

f. Calibrate. To determine and cause corrections to be made or to be adjusted on instruments or test, measuring, and diagnostic equipment used in precision measurement Consists of comparisons of two instruments, one of which is a certified standard of known accuracy, to detect and adjust any discrepancy in the accuracy of the Instrument being compared.

g. Remove/Install. To remove and install the same item when required to perform service or other maintenance functions Install may be the act of emplacing, seating, or fixing into position a spare, repair part, or module (component or assembly) m a manner to allow the proper functioning of an equipment or system

h. Replace. To remove an unserviceable item and install a serviceable counterpart m its place. "Replace" is authorized by the MAC and assigned maintenance level is shown as the 3d position code of the SMR code.

i. Repair. The application of maintenance services', including fault location/troubleshooting², removal/installation, and disassembly/assembly³ procedures, and maintenance actions⁴ to identify troubles and restore serviceability to an item by correcting specific damage, fault, malfunction, or failure m a part, subassembly, module (component or assembly), end item, or system

j. Overhaul. That maintenance effort (service/action) prescribed to restore an item to a completely serviceable/ operational condition as required by maintenance standards m appropriate technical publications (i e., DMWR) Overhaul is normally the highest degree of maintenance performed by the Army Overhaul does not normally return an Item to like new condition

k. Rebuild. Consists of those services/actions necessary for the restoration of unserviceable equipment to a like new condition in accordance with original manufacturing standards. Rebuild is the highest degree of material maintenance applied to Army equipment The rebuild operation includes the act of returning to zero those age measurements (e.g., hours/miles) considered m classifying Army equipment/components.

B-3. EXPLANATION OF COLUMNS IN THE MAC, SECTION II.

a. Column 1, Group Number. Column 1 lists functional group code numbers, the purpose of which is to identify maintenance significant components, assemblies, subassemblies, and modules with the next higher assembly

b. Column 2, Component/Assembly. Column 2 contains the names of components, assemblies, subassemblies, and modules for which maintenance is authorized.

¹Services - Inspect, test, service, adjust, align, calibrate, and/or replace

²Fault location/troubleshooting - The process of investigating and detecting the cause of equipment malfunctioning; the act of isolating a fault within a system or unit under test (UUT).

³Disassembly/assembly - The step-by-step breakdown (taking apart) of a spare/functional group coded item to the level of its least component, that is assigned an SMR code for the level of maintenance under consideration (e.g., identified as maintenance significant).

⁴Actions - Welding, grinding, riveting, straightening, facing, machining, and/or resurfacing.

B-3. EXPLANATION OF COLUMNS IN THE MAC. SECTION II.-Continued

c. Column 3. Maintenance Functions. Column 3 lists the functions to be performed on the item listed in column 2. (For detailed explanation of these functions, see paragraph B-2).

d. Column 4. Maintenance Level. Column 4 specifies each level of maintenance authorized to perform each function listed in column 3, by indicating work time required (expressed as man-hours in whole hours or decimals) in the appropriate subcolumn. This work-time figure represents the active time required to perform that maintenance function at the indicated level of maintenance. If the number or complexity of the tasks within the listed maintenance function vary at different maintenance levels, appropriate work-time figures are to be shown for each level. The work-time figure represents the average time required to restore an item (assembly, subassembly, component, module, end item, or system) to a serviceable condition under typical field operating conditions. This time includes preparation time (including any necessary disassembly/assembly time), troubleshooting/fault location time, and quality assurance time in addition to the time required to perform the specific tasks identified for the maintenance functions authorized in the maintenance allocation chart. The symbol designations for the various maintenance levels are as follows:

C.....Operator or Crew Maintenance

O..... Unit Maintenance

F..... Direct Support Maintenance

H General Support Maintenance

e. Column 5. Tools and Equipment Reference Code. Column 5 specifies, by code, those common tool sets (not individual tools) common, TMDE, and special tools, special TMDE, and special support equipment required to perform the designated function. Codes are keyed to tools and test equipment in section III.

f. Column 6. Remarks. When applicable, this column contains a letter code, in alphabetical order, which is keyed to the remarks contained in Section IV.

⁵This maintenance level is not included in Section II, column (4) of the Maintenance Allocation Chart. Functions to this level of maintenance are identified by a work-time figure in the "H" column of Section II, column (4), and an associated reference code is used in the Remarks column (6). This code is keyed to Section IV, Remarks, and the SRA complete repair application is explained there.

B-4. EXPLANATION OF COLUMNS IN TOOL AND TEST EQUIPMENT REQUIREMENTS, SECTION III.

- a. Column 1, Reference Code. The tool and test equipment reference code correlates with a code used in the MAC, Section II, Column 5.
- b. Column 2, Maintenance Level. The lowest level of maintenance authorized to use the tool or test equipment.
- c. Column 3, Nomenclature. Name or identification of the tool or test equipment.
- d. Column 4, National Stock Number. The National stock number of the tool or test equipment.
- e. Column 5, Tool Number. The manufacturer's part number or type number.

B-5. EXPLANATION OF COLUMNS IN REMARKS, SECTION IV.

- a. Column 1, Remarks Code. The code recorded in column 6, Section II.
- b. Column 2, Remarks. This column lists information pertinent to the maintenance function being performed as indicated in the MAC, Section II.

Section II. MAINTENANCE ALLOCATION CHART

(1) GROUP NUMBER	(2) COMPONENT ASSEMBLY	(3) MAINTENANCE FUNCTION	(4) MAINTENANCE LEVEL					(5) TOOLS AND EQUIP	(6) REMARKS
			UNIT		DS	GS	Depot		
			C	O	F	H	D		
00 01	REFRIGERATION UNIT PANELS & GUARDS								
	Bolts, Barrel	Inspect Service Replace	0.1	0.1 0.5				1 1	
	Panels	Inspect Replace	0.1	0.5				1	
	Guards	Inspect Replace	0 1	0.5				1	
	Bolt Assembly, Unit Mounting	Inspect Replace	0 1	0.5				1	
02	ELECTRICAL AND CONTROL								
	Wires, Cables, & Harnesses	Inspect Test Repair Replace		0.5 0.5 1.0 2.0				1 1 1, 3 1, 3	
	Circuit Breaker CB1	Inspect Test Replace		0 1 0.5 1 0				1 1 1	
	Lamp Assembly DS1	Inspect Test Replace		0 1 0.5 1 0				1 1 1	
	Fuses F1 and F2	Inspect Test Replace		0.1 0.5 0 2				1 1 1	
	Motor Starter K1	Inspect Test Repair Replace		0 1 0.5 0.5 1 0				1 1 1 1	
	Contactors K2	Inspect Test Replace		0 1 0.5 1 0				1 1 1	
	Relays K3 and K4, Control	Inspect Test Replace		0 1 0.5 1.0				1 1 1	

Section II. MAINTENANCE ALLOCATION CHART

(1) GROUP NUMBER	(2) COMPONENT ASSEMBLY	(3) MAINTENANCE FUNCTION	(4) MAINTENANCE LEVEL					(5) TOOLS AND EQUIP	(6) REMARKS	
			UNIT		DS	GS	Depot			
			C	O	F	H	D			
03	Hourmeter M1	Inspect		0.1				1		
		Test		0.5				1		
		Replace		1.0				1		
	Switch S1, Toggle	Inspect		0.1				1		
		Test		0.5				1		
		Replace		1.0				1		
	Timer TM1, Repeat Cycle	Inspect		0.1				1		
		Test		0.5				1		
		Replace		1.0				1		
	Thermostat S3, Remote Bulb	Inspect		0.1				1		
		Test		0.5				1		
		Replace		1.0				1		
	Switches S6 and S7, Push	Inspect		0.1				1		
		Test		0.5				1		
		Replace		0.5				1		
	POWER TRANSMISSION/AIR HANDLING	Belt	Inspect	0.1						
			Adjust		0.5				1	
			Replace		0.5				1	
		Pulley	Inspect	0.1						
			Replace		0.1				1	
		Motor B2, AC	Inspect		0.1					
			Test		1.0				1	
			Replace		1.0				1	
		Fan, Condenser	Inspect		1.0					
			Replace		0.5				1	
		Fan, Evaporator	Inspect		0.5				1	
			Replace		0.5				1	
Pulley (Sheave & Bushing)		Inspect	0.1							
		Replace		0.1				1		
Shaft, Fan Drive		Inspect	0.1							
		Replace			4.0			1		
Bearings, Flange		Inspect		0.5				1		
		Service		0.2				1		
		Replace		2.0				1		

Section II. MAINTENANCE ALLOCATION CHART

(1) GROUP NUMBER	(2) COMPONENT ASSEMBLY	(3) MAINTENANCE FUNCTION	(4) MAINTENANCE LEVEL					(5) TOOLS AND EQUIP	(6) REMARKS
			UNIT		DS	GS	Depot		
			C	O	F	H	D		
04	REFRIGERATION SYSTEM								
	Dehydrator	Inspect	0.1						
		Replace			3.0			2, 5	
	Strainer	Inspect	0.1						
		Replace			3.0			2, 5	
	Valves, Isolation	Inspect	0.1						
		Replace			3.0			2, 5	
	Receiver	Inspect	0.1						
		Replace			3.0			2, 5	
	Condenser	Inspect		0.1					
		Service		1.0				1, 6	
		Replace			4.0			2, 4, 5	
	Valve, Pressure Regulator (Discharge)	Inspect	0.1						
		Replace			3.0			2, 4, 5	
	Hose Assembly, Metal (Discharge)	Inspect	0.1						
		Replace			3.0			2, 4, 5	
	Valve, Pressure Regulator (Suction)	Inspect	0.1						
		Replace			3.0			2, 4, 5	
	Hose Assembly, Metal (Suction)	Inspect	0.1						
		Replace			3.0			2, 4, 5	
	Accumulator	Inspect	0.1						
		Replace			3.0			2, 4, 5	
	Valves L1 and L2, Solenoid	Inspect	0.1						
		Test		0.3				1	
		Repair		1.0		3.0		2, 5	A
		Replace				3.0		2, 5	
	Valves, Packless Stop	Inspect	0.1						
		Replace				3.0		2, 4, 5	
	Indicator, Sight	Inspect	0.1						
		Replace				3.0		2, 5	
Switch S5, Differential Oil Pressure	Inspect	0.1							
	Replace				3.0		2, 5		
Switch S2, Dual Pressure Control	Inspect	0.1							
	Replace				3.0		2, 5		
Thermometer	Inspect	0.1							
	Replace			0.5			1		
Pressure Gage (Discharge)	Inspect	0.1							
	Replace				3.0		2, 5		

Section II. MAINTENANCE ALLOCATION CHART

(1) GROUP NUMBER	(2) COMPONENT ASSEMBLY	(3) MAINTENANCE FUNCTION	(4) MAINTENANCE LEVEL					(5) TOOLS AND EQUIP	(6) REMARKS
			UNIT		DS	GS	Depot		
			C	O	F	H	D		
05	Pressure Gage (Suction)	Inspect	0	1					
		Replace			3.0			2, 5	
	Thermostat S4, Defrost Termination	Inspect		0.1				1	
		Test		0.5				1	
		Replace		1.0				1	
	Heat Interchanger	Inspect		0.1				1	
		Replace			4.0			1, 4, 5	
	Valve, Expansion	Inspect		0.1				1	
		Replace			3.0			2, 5	
	Coil, Evaporator	Inspect		0.1				1	
		Service		1.0				1, 6	
	Compressor B1	Replace			4.0			2, 4, 5	
		Inspect	0.1					1	
		Service			0.5			2, 5	
		Test			0.5			2, 5	
		Repair			10.0			2, 4, 5	
		Replace			6.0			2, 4, 5	
	Tubing and Fittings	Inspect		1.0				1	
		Test			1.0			2	
		Repair			1.0			2, 4, 5	
		Replace			3.0			2, 4, 5	
	ENCLOSURE								
	Gaskets, Heat Shield	Inspect	0.1						
	Replace		1.0				1		
Plates (Data)	Inspect	0.1							
	Replace			1.0			1		
Doors and Cover	Inspect	0.1							
	Service		0.5				1		
	Repair			1.0			1		
	Replace			0.5			1		
Frame	Inspect	0.1							
	Repair			2.0	6.0		1	B	

SECTION III. TOOL AND TEST EQUIPMENT REQUIREMENTS FOR REFRIGERATION UNIT

Tool or Test Equipment Ref Code	Maintenance Level	Nomenclature	National Stock Number	Tool Number
NOTE				
Standard tools and test equipment in the following kits are adequate to accomplish the maintenance functions listed in Section II:				
1	O	Shop Equipment (1), Automotive Vehicle	4910-00-754-0654	SC 4910-95-CL-A74
2	O	Comb, Fin	5120-00-916-6197	
3	O	Heat Gun	3439-01-037-7268	
4	F	Tool Kit, Service, Refrigeration Unit	5180-00-597-1474	SC 5180-90-CL-N18
5	F	Recovery and Recycle Unit, Refrigerant	4130-01-338-2707	
6	F	Nitrogen Regulator	6680-00-503-1327	

SECTION IV. REMARKS FOR REFRIGERATION UNIT

Reference Code	Remarks
A	Repair at unit maintenance level is limited to replacement of electric coil.
B	Repair at general support maintenance level is limited to welding condenser frame only.

APPENDIX C**COMPONENTS OF END ITEM (COEI) AND BASIC ISSUE ITEMS LIST****SECTION I. INTRODUCTION****C-1. SCOPE.**

This appendix list components of the end item and basic issue items for the refrigeration unit to help you inventory the items for safe and efficient operation of the equipment.

C-2. GENERAL.

The Components of End Item (COEI) and Basic issue Items (BII) Lists are divided into the following sections:

a. Section II, Components of End Item. This listing is for information purposes only, and is not authority to requisition replacements. These items are part of the refrigeration unit. As part of the end item, these items must be with the end item whenever it is issued or transferred between property accounts. Items of COEI are removed and separately packaged for transportation or furnished to help you find and identify the items.

b. Section III, Basic Issue Items. These essential items are required to place the refrigeration unit in operation, operate it, and to do emergency repairs. Although shipped separately packaged, BII must be with the refrigeration unit during operation and when it is transferred between property accounts. This list is your authority to request/requisition them for replacement based on authorization of the end item by the TOE/MTOE. Illustrations are furnished to help you find and identify the items.

c. Explanation of Columns.

(1) Column (1), Illus Number, gives you the number of the item illustrated.

(2) Column (2), National Stock Number, identifies the stock number of the item to be used for requisitioning purposes

(3) Column (3), Description and Usable On Code, identifies the Federal item name (in all capital letters) followed by a minimum description when needed. The last line below the description is the Commercial and Government Entity Code (CAGEC) (m parentheses) and the part number.

(4) Column (4), U/I (unit of issue), indicates how the item is issued for the National Stock Number shown in column two

(5) Column (5), Qty Rqd, indicates the quantity required.

SECTION II. COMPONENTS OF END ITEM

There are no loose or separate components supplied with this refrigeration unit.

SECTION III. BASIC ISSUE ITEMS LIST

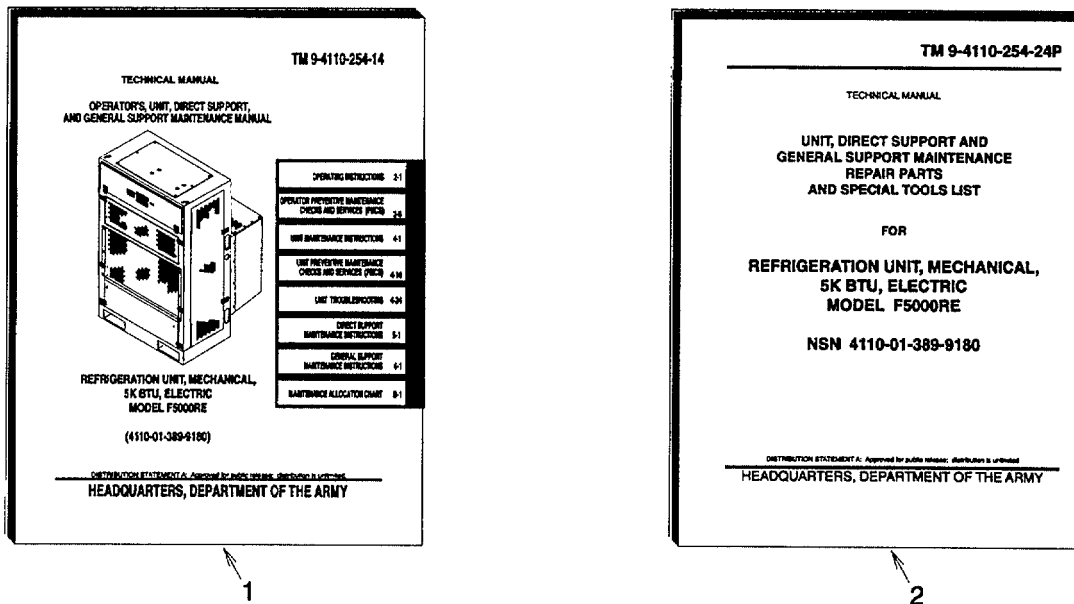

Figure C-1. Basic Issue Items

(1) Illus Number	(2) National Stock Number	(3) Description CAGEC and Part Number	(4) U/M	(5) Qty Rqd.
1		ARMY TECHNICAL MANUAL Operator's, Unit, Direct Support and General Support Maintenance for Refrigeration Unit, Mechanical 5K BTU Electric, Model F5000RE TM 9-4110-254-14	EA	1
2		ARMY TECHNICAL MANUAL Unit, Direct Support and General Support Maintenance Repair Parts and Special Tools List for Refrigeration Unit, Mechanical, 5K BTU, Electric Model F5000RE TM 9-4110-254-24P	EA	1

APPENDIX D

ADDITIONAL AUTHORIZATION LIST

There are no additional authorized items required for this refrigeration unit.

APPENDIX E

EXPENDABLE AND DURABLE ITEMS LIST

SECTION I. INTRODUCTION

E-1. SCOPE.

This appendix lists expendable and durable items you will need to maintain the refrigeration unit. This listing is for informational purposes only and is not authority to requisition the listed items. These items are authorized by CTA 50-970, expendable items (except Medical, Class V, Repair Parts, and Heraldic Items).

E-2. EXPLANATION OF COLUMNS.

- a. Column (1)-Item Number This number is assigned to the entry in the listing for referencing when required.
- b. Column (2)-Level This column identifies the lowest level of maintenance that requires the listed item.

C - Operator/Crew

O - Unit Maintenance

F - Direct Support Maintenance

H - General Support Maintenance

- c. Column (3)-National Stock Number. This is the national stock number assigned to the item, use it to request or requisition the item

- d. Column (4)-Description. Indicates the federal item name and, if required a description to identify the item. The last line for each item indicates the Commercial and Government Entity Code (CAGEC) in parentheses followed by the part number.

- e. Column (5)-Unit of Measure (U/M) Unit of Issue (U/I). This measure is expressed by a two character alphabetical abbreviation (e.g., EA, IN, PR). If the unit of measure differs from the unit of issue as shown in the Army Master Data File (AMDF) requisition the lowest unit of issue that will satisfy your requirements.

SECTION II. EXPENDABLE AND DURABLE ITEMS LIST

(1) Item Number	(2) Level	(3) National Stock Number	(4) Description	(5) (U/M)/ (U/I)
1	O	7510-00-266-5006	Tape, Waterproof Packaging, PPP-T-60, Type IV	roll
2	O	8135-00-664-6958	Greaseproofed, Waterproof, Flexible Barrier Material, PP-C-843, Type II Class B	roll
3	C	7920-00-205-1711	Wiping Rag	bl
4	C	7930-00-985-6911	Detergent (81349) MIL-D-16791	gl
5	O	9150-01-178-4725	Lubricating Oil, General Purpose MIL L.-2104	qt
6	O	9150-00-985-7316	Grease, Multipurpose MIL-G-23549	lb
7	O	9905-00-537-8954	Marker Tag, MIL-T-12755	box
8	O	5935-00-725-4153	Solder, Lead-Tin, QQ-S-571 Type SN60WRP2	
9	F	3439-00-640-3713	Flux, Brazing O-F-499, type B	oz
10	O	5640-00-580-6276	Insulation Tape	roll
11	F	6830-00-292-0732	Nitrogen	cy
12	F	6830-01-380-4960	Refrigerant, R134a	lb
13	O	5350-00-192-5047	Abrasive Cloth	pg
14	O	3040-00-644-0439	Adhesive, General Purpose,	pt
15	F		Brazing Alloy, Silver QQ-B-564, grade O, I or II	oz
16	F		Brazing Alloy, Silver QQ-B-564, grade III	oz
17	O	3439-01-045-7940	Flux, Solder, Liquid, Rosin Base MIL-F-14256	qt
18	F		Acetone	gl
19	F		Methyl-ethyl Ketone	gl
20	O		Adhesive-Sealant, Silicone RTV MIL-A-46106, Type I	oz

(1) Item Number	(2) Level	(3) National Stock Number	(4) Description	(5) (U/M)/ (U/I)
21	F	,	Lubricating 011, Compressor, Refrigeration (14569) Arctic 22 CC	gl
22	F		Tape, Anti-Seize MIL-T-27730, Size 1	roll
23	O		Tiedown Strap, (96906) MS3367-4-9	hd
24	O		Tiedown Strap, (96906) MS3367-2-9	hd
25	O		Tiedown Strap, (96906) MS3367-5-9	hd
26	F		Rivet, (94833) 500K2032-8	hd
27	F		Rivet, (94833) 500K2031-151	hd
28	F		Tie Down Strap, (96906) MS3367-7-9	hd
29	F		Rivet, (94833) 500K2031-139	hd

APPENDIX F

ILLUSTRATED LIST OF MANUFACTURED ITEMS

SECTION I.

F-1. SCOPE.

This appendix includes complete instructions for making items authorized to be manufactured or fabricated at unit, and direct support maintenance.

- a. A part number index in alphanumeric order is provided for cross-referencing the part number of the item to be manufactured to the figure which covers fabrication criteria.
- b. All bulk materials needed for manufacture of an item are listed by part number or specification number in a tabular list on the illustration.
- c. All dimensions are given in inches with centimeters shown in parenthesis.
- d. For fabrication information of electrical wires including lengths and markings, see Table 4-3.

SECTION II.

F-2. MANUFACTURED ITEMS PART NUMBER LIST.

<u>Part Number</u>	<u>Figure Number</u>
12075-5-9375	F-1
12075-7-1500	F-1
12075-7-2375	F-4
12075-9-2875	F-1
12075-9-9500	F-1
12076-3-1000	F-2
12076-5-2125	F-2
12076-5-2500	F-2
12076-5-938	F-2
12284-5-5000	F-5
12284-5-9750	F-5
12290-8-8000	F-6
148K0143	F-7
148K0144	F-8
148K0168	F-9
148K0169-1T	F-10

F-2. MANUFACTURED ITEMS PART NUMBER LIST. -Continued

<u>Part Number</u>	<u>Figure Number</u>
148K0170	F-1
148K0171	F-11
148K0172	F-1
148K0173.....	F-12
148K0174	F-13
148K0239-1/3.....	F-5
148K0239-1/4.....	F-5
149K0000-1/99.....	F-14
149K0000-1/141	F-3
149K0000-1/162	F-15
149K0000-1/178	F-3
149K0009-1/50	F-3
149K0032.....	F-16
149K0051-1/3.....	F-1
149K0051-3/3.....	F-1
149K0052-1/T	F-17
149K0053-1/T	F-18
149K0074	F-19
149K0057	F-20
149K0058	F-21
149K0059.....	F-22
149K0075.....	F-23
149K0061	F-24
149K0063-1/T	F-25
149K0064-1/T	F-26
149K0065	F-27
149K0072-1	F-28
149K0072-3	F-5
149K0073	F-5
150K0096	F-5
150K0030	F-5

<u>Part Number</u>	<u>Figure Number</u>
151K0031	F-29
151K0042-1/4	F-3
152K0194	F-30
500K1662-3-3.36	F-4

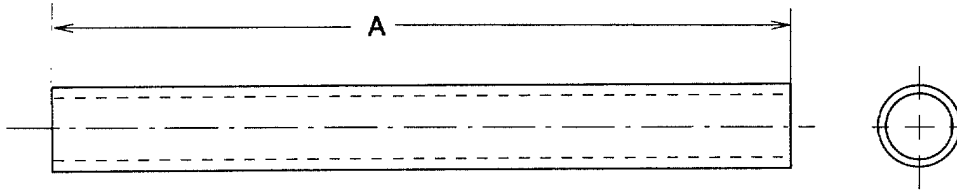

ITEM	PART NO.	DIM "A"	FABRICATE FROM
1	12075-5-9375	9.375 (23.813)	0.375 (.953) O.D. X 0.032 (0.081) WALL ASTM B280 COPPER TUBING
2	12075-7-1500	1.500 (3.81)	0.625 (1.588) O.D. X 0.035 (0.089) WALL ASTM B280 COPPER TUBING
3	12075-7-2375	2.375 (6.03)	0.625 (1.588) O.D. X 0.035 (0.089) WALL ASTM B280 COPPER TUBING
4	12075-9-2875	2.875 (7.30)	0.875 (2.223) O.D. X 0.045 (0.114) WALL ASTM B280 COPPER TUBING
5	12075-9-9500	9.50 (24.13)	0.875 (2.223) O.D. X 0.045 (0.114) WALL ASTM B280 COPPER TUBING
6	148K0170	1.13 (2.87)	0.375 (.953) O.D. X 0.032 (0.081) WALL ASTM B280 COPPER TUBING
7	148K0172	1.25 (3.17)	0.625 (1.588) O.D. X 0.035 (0.089) WALL ASTM B280 COPPER TUBING
8	149K0051-1/3	40.00 (101.6)	0.125 (.318) O.D. X 0.030 (0.076) WALL ASTM B280 COPPER TUBING
9	149K0051-3/3	90.00 (228.60)	0.125 (.318) O.D. X 0.030 (0.076) WALL ASTM B280 COPPER TUBING

Figure F-1. Tube, Copper Straight, Various

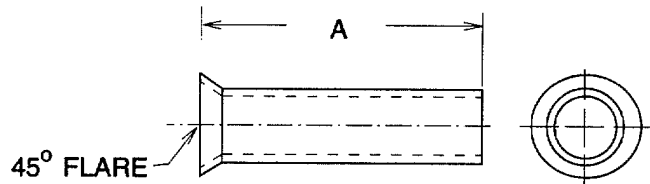

ITEM	PART NO.	DIM "A"	FABRICATE FROM
1	12076-3-1000	1.000 (2.540)	0.250 (0.635) O.D. X 0.030 (0.076) WALL ASTM B280 COPPER TUBING
2	12076-5-2125	2.125 (5.398)	0.375 (.953) O.D. X 0.032 (0.081) WALL ASTM B280 COPPER TUBING
3	12076-5-2500	2.500 (6.350)	0.375 (.953) O.D. X 0.032 (0.081) WALL ASTM B280 COPPER TUBING
4	12076-5-938	0.938 (2.383)	0.375 (.953) O.D. X 0.032 (0.081) WALL ASTM B280 COPPER TUBING

Figure F-2. Tubing-Copper, Straight Flared, Various

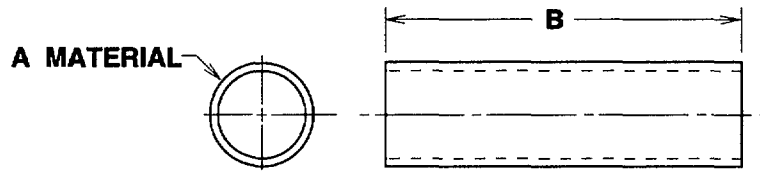

ITEM	PART NUMBER	FABRICATE FROM MATERIAL A	B LENGTH
1	149K0000-1/141	M23053/5-106-9 INSULATION, SLEEVING, HEAT SHRINKABLE	1.50 (3.81)
2	149K0000-1/178	M23053/5-107-9 INSULATION, SLEEVING, HEAT SHRINKABLE	1.50 (3.81)
3	149K0009-1/50	M23053/5-107-9 INSULATION, SLEEVING, HEAT SHRINKABLE	.88 (2.24)
4	151K0042-1/4	M23053/5-102-0 INSULATION, SLEEVING, HEAT SHRINKABLE	1.50 (3.81)

Figure F-3. Insulation Sleeving

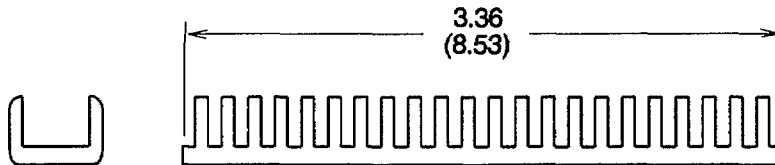

NOTE

1. FABRICATE FROM (03296) CATERPILLAR GROMMET FOR .085/.128 (.216/.325) SHEET THICKNESS

Figure F-4. Grommet, Part Number 500K1662-3-3.36

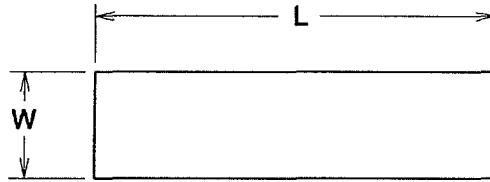

ITEM	PART NUMBER	W DIM	L DIM	FABRICATE FROM
1	148K0239-1/3	.50 (1.27)	4.88 (12.40)	ASTM D1056-2A2C2F2 0.125 (0.318) THICK RUBBER GASKET
2	148K0239-1/4	.50 (1.27)	6.50 (16.51)	ASTM D1056-2A2C2F2 0.125 (0.318) THICK RUBBER GASKET
3	149K0072-3	1.00 (2.54)	9.13 (85.09)	ASTM D1056-2A2C2F2 0.125 (0.318) THICK RUBBER GASKET
4	149K0073	.56 (1.42)	33.50 (85.09)	ASTM D1056-2A2C2F2 0.063 (0.158) THICK RUBBER GASKET
5	150K0096	.50 (1.27)	6.84 (17.37)	ASTM D1056-2A2C2F2 0.125 (0.318) THICK RUBBER GASKET
6	151K0030	.50 (1.27)	5.88 (14.94)	ASTM D1056-2A2C2F2 0.125 (0.318) THICK RUBBER GASKET
7	12284-5-5000	.50 (1.27)	5.00 (12.70)	ASTM D1056-2A2C2F2 0.125 (0.318) THICK RUBBER GASKET
8	12284-5-9750	.50 (1.27)	9.75 (24.77)	ASTM D1056-2A2C2F2 0.125 (0.318) THICK RUBBER GASKET

Figure F-5. Gasket, Various

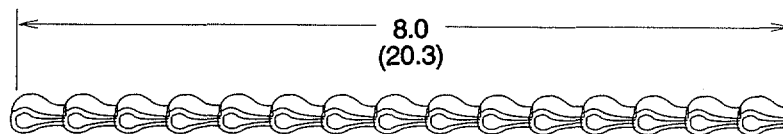

NOTE

1. FABRICATE FROM NUMBER 8 SASH CHAIN

Figure F-6. Chain, Sash, Part Number 12290-8-8000

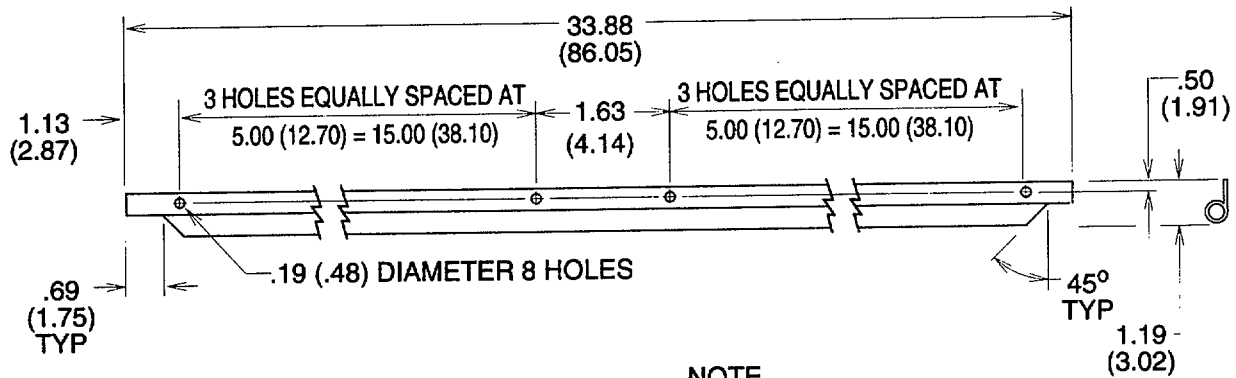

NOTE
1. FABRICATE FROM (74951) V-1234-100

Figure F-7. Gasket, Top/Bottom, Part Number 148K0143

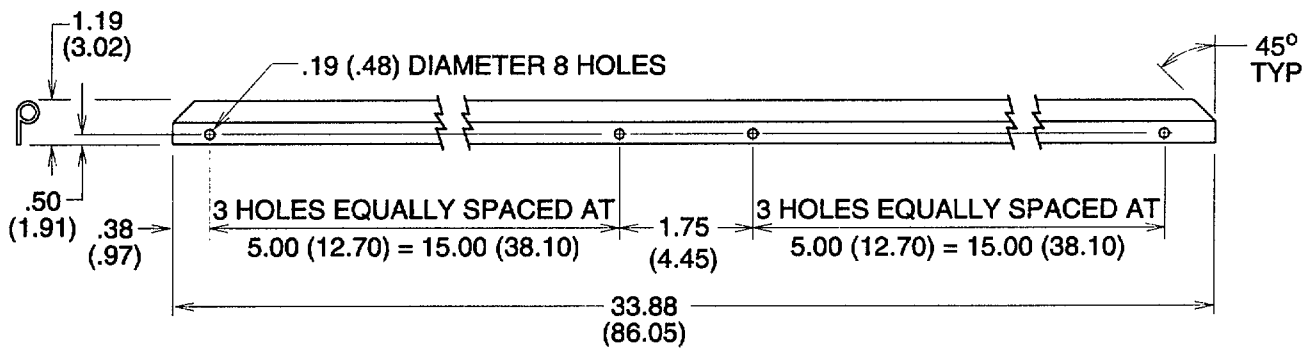

NOTE
1. FABRICATE FROM (74951) V-1234-100

Figure F-8. Gasket, Right/Left, Part Number 148K0144

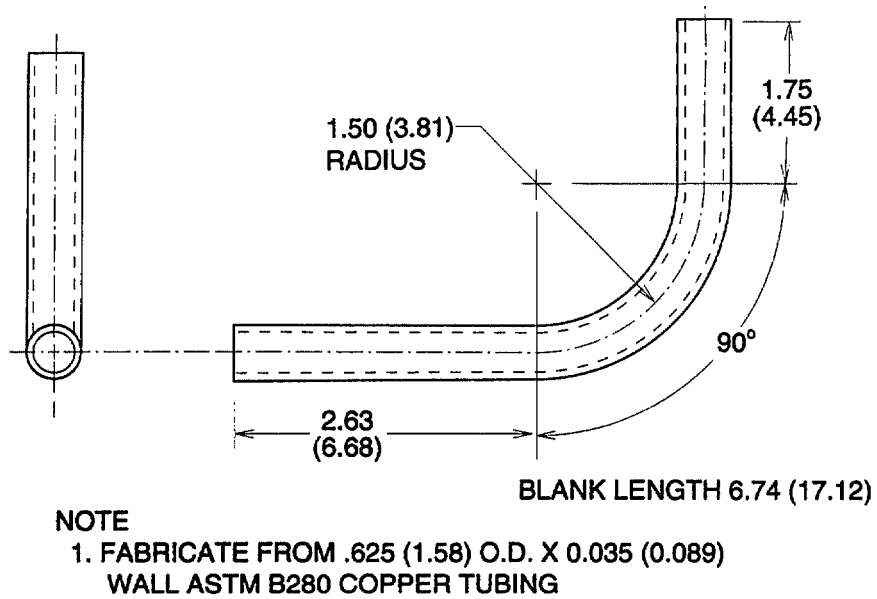

Figure F-9. Tube, Coil to Heat Exchanger, Part Number 148K0168

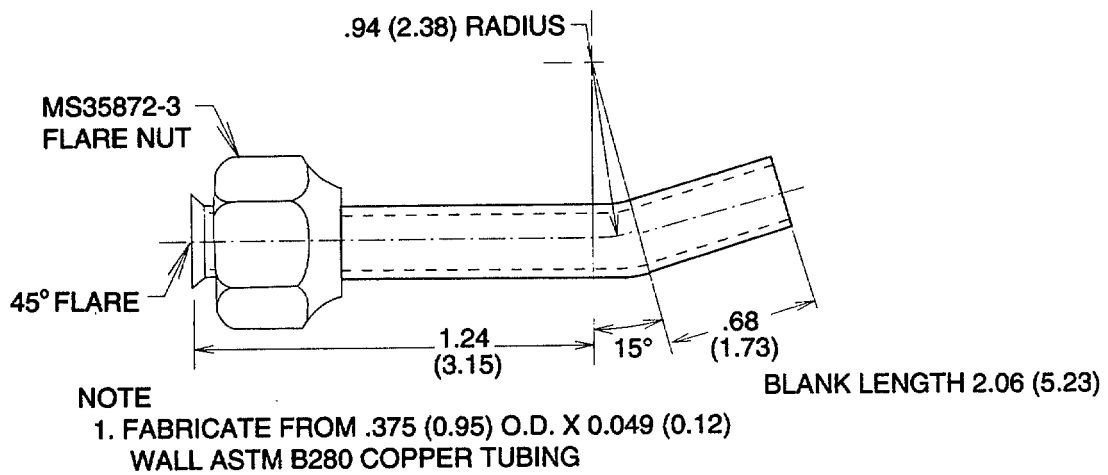

Figure F-10. Tube Expansion, Valve to Heat Exchanger, Part Number 148K0169

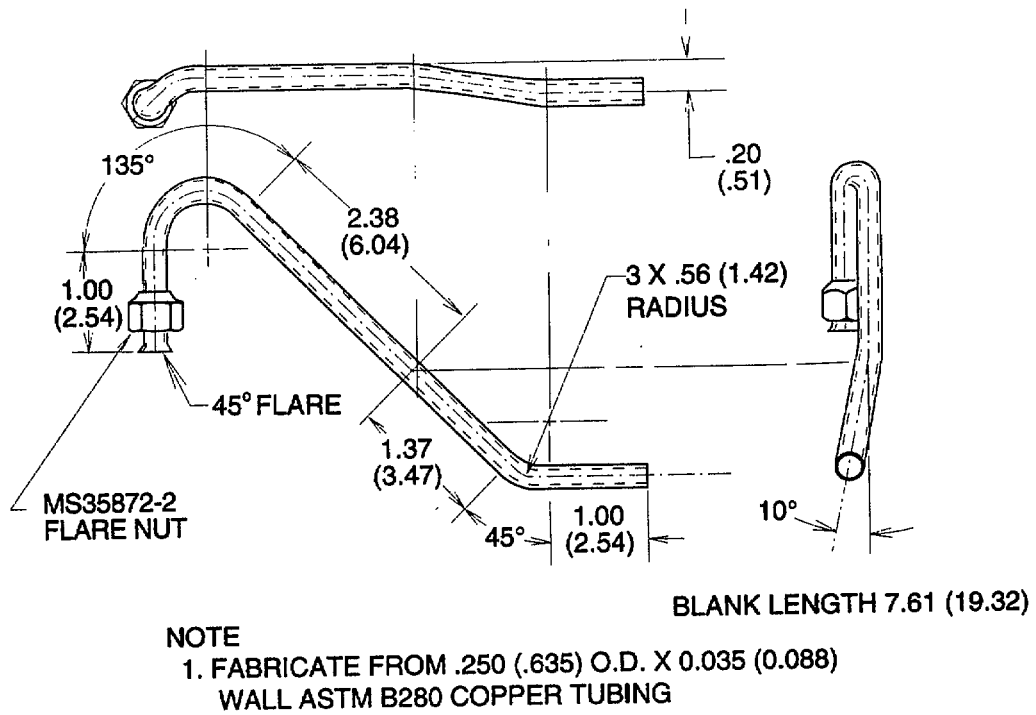

Figure F-11. Tube, Expansion Valve Bypass, Part Number 148K0171

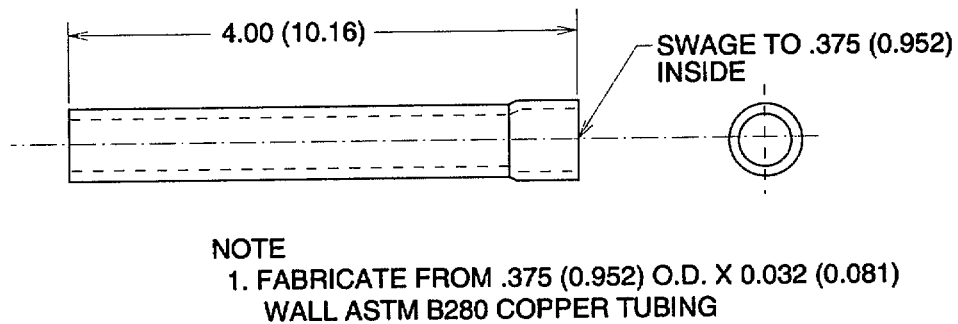
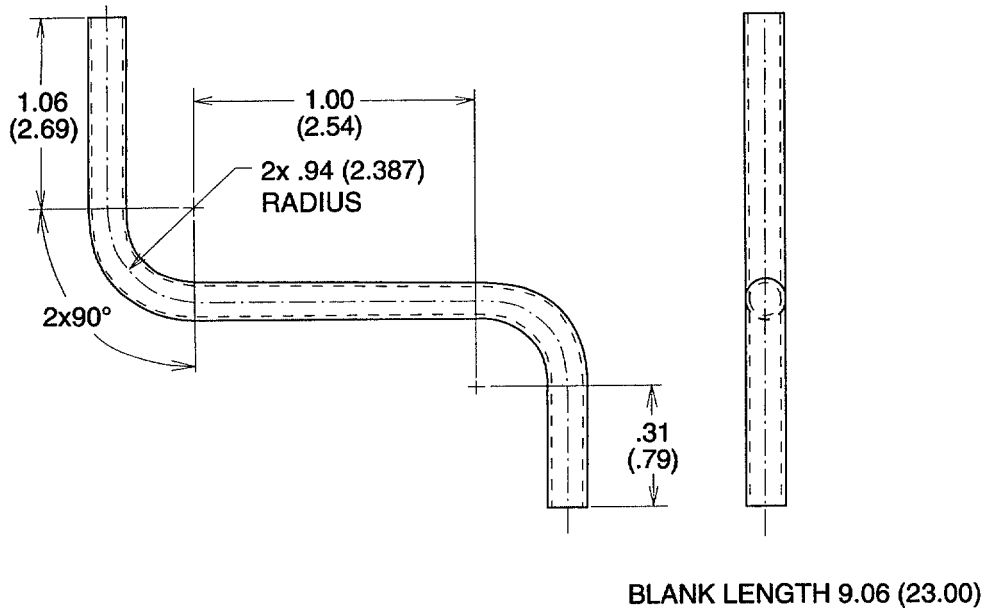
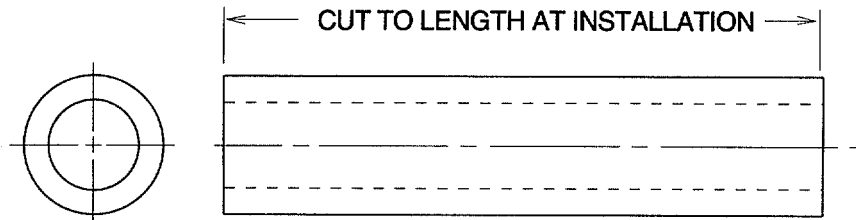

Figure F-12. Tube, 0.375 Tee to Defrost Coil, Part Number 148K0173



NOTE
 1. FABRICATE FROM .38 (.965) O.D. X 0.032 (0.081)
 WALL ASTM B280 COPPER TUBING

Figure F-13. Tube, Heat Exchanger to 0.375 Elbow, Part Number 148K0174



NOTE
 1. FABRICATE FROM MIL-P-15280, FORM T, 0.875 (2.222) INSIDE DIAMETER
 X 0.50 (1.27) WALL INSULATION TUBING.

Figure F-14. Tubing, Insulation, Part Number 148K0000-1/99

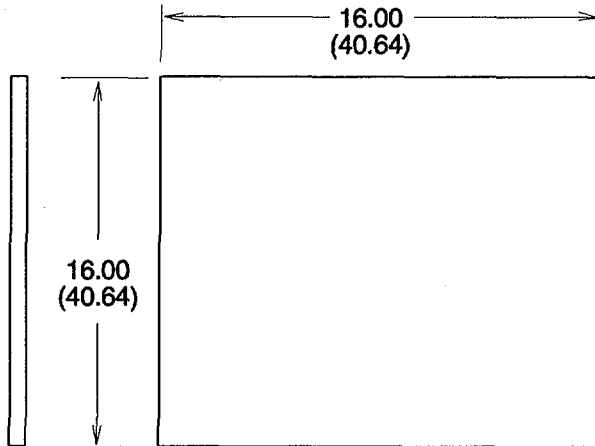

NOTE

1. FABRICATE FROM (97403) 13225E8562 INSULATION SHEET

Figure F-15. Insulation Sound and Temperature, Part Number 149K0000-1/162

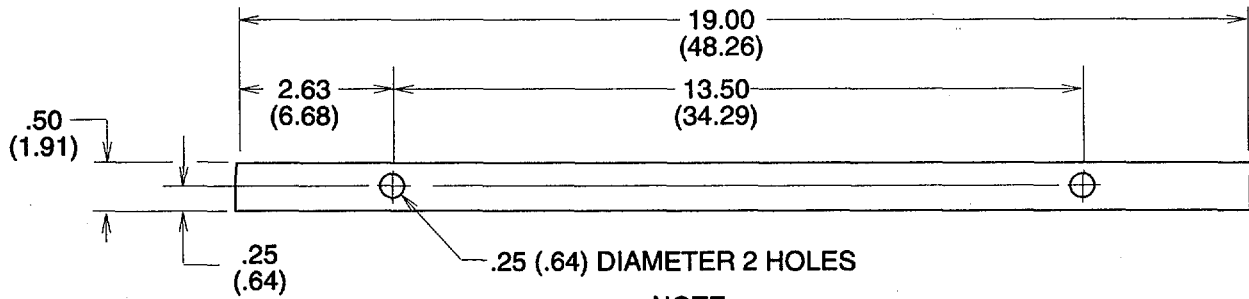

NOTE

1. FABRICATE FROM ASTM D1056-2A2C2F2 0.125 (0.318) THICK RUBBER GASKET

Figure F-16. Gasket, Control Box, Top, Part Number 149K0032

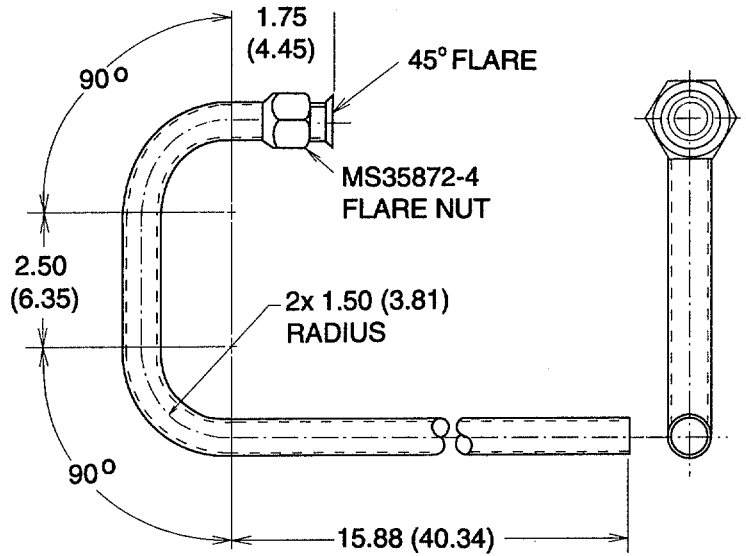

BLANK LENGTH 24.85 (63.12)

NOTE

1. FABRICATE FROM .625(1.58) O.D. X 0.035 (0.88) WALL ASTM B280 COPPER TUBING

Figure F-17. Tube Assembly Inlet, Receiver, Part Number 149K0052-1/T

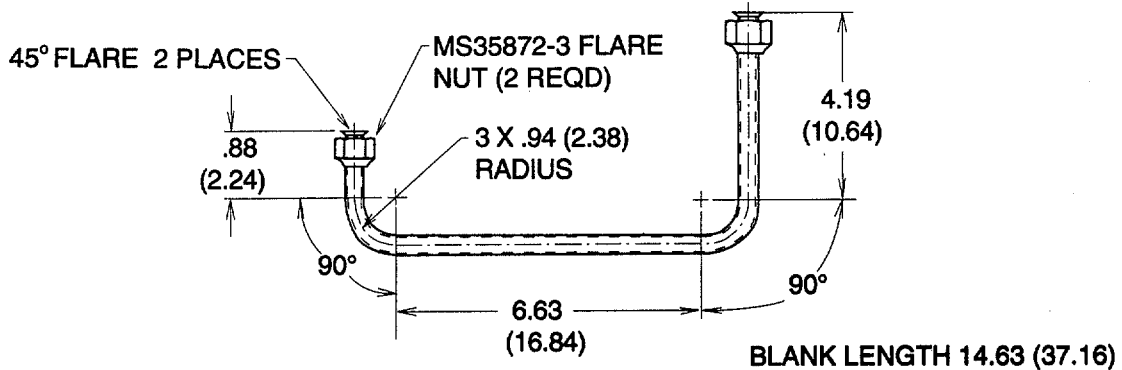

BLANK LENGTH 14.63 (37.16)

NOTE

1. FABRICATE FROM .375 (.952) O.D. X 0.030 (0.076) WALL ASTM B280 COPPER TUBING

Figure F-18. Tube Assembly, Outlet Receiver, Part Number 149K0053-1/T

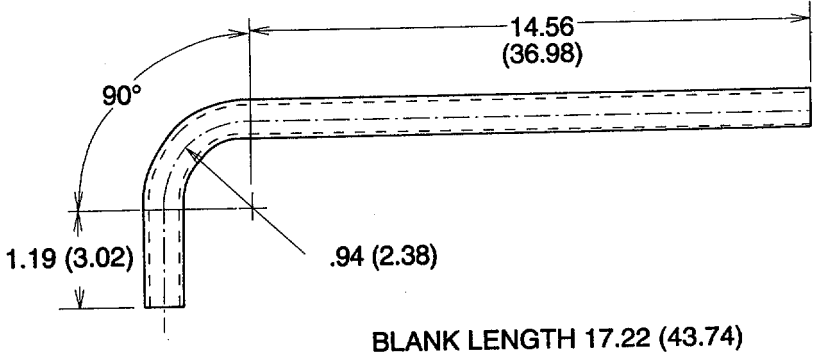

NOTE
1. FABRICATE FROM .375 (.95) O.D. X 0.030 (0.76)
WALL ASTM B280 COPPER TUBING

Figure F-19. Tube, Elbow to Elbow, Sight Glass Outlet, Part Number 149K0074

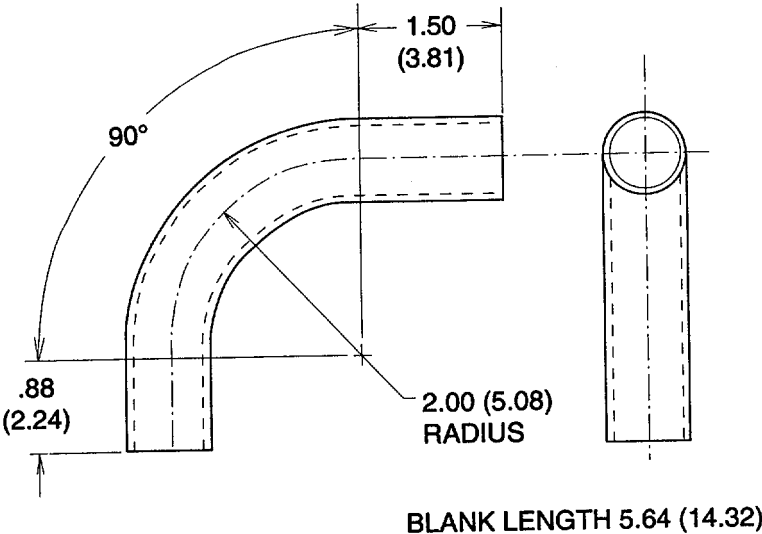

NOTE
1. FABRICATE FROM .875 (2.22) O.D. X 0.045 (2.54)
WALL ASTM B280 COPPER TUBING

Figure F-20. Tube, Outlet, Accumulator, Part Number 149K0057

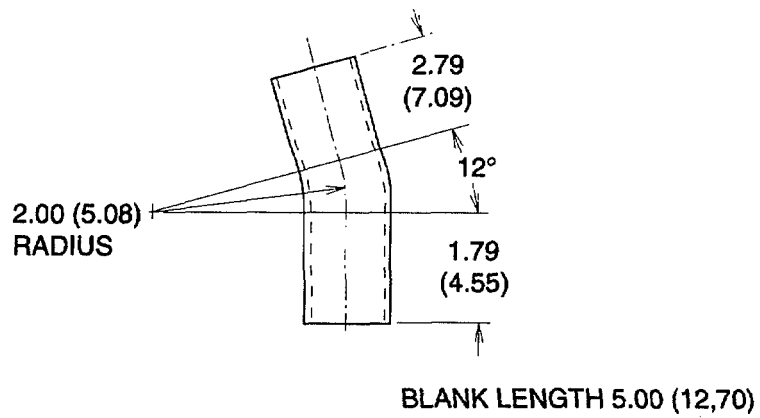

NOTE

1. FABRICATE FROM .875 (2.22) O.D. X 0.045 (2.23) WALL ASTM B280 COPPER TUBING

Figure F-21. Tube, Outlet, Suction Pressure Regulator Valve, Part Number 149K0058

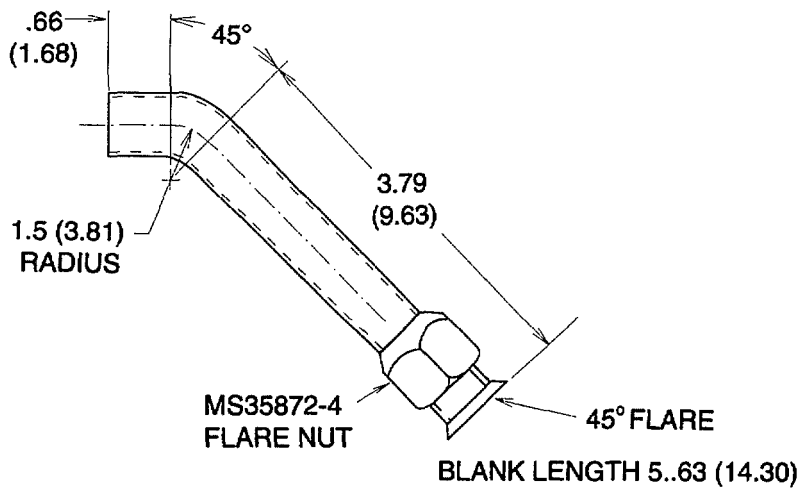

NOTE

1. FABRICATE FROM .625 (1.58) O.D. X 0.035 (0.88) WALL ASTM B280 COPPER TUBING

Figure F-22. Tube, Outlet, Compressor, Part Number 149K0059

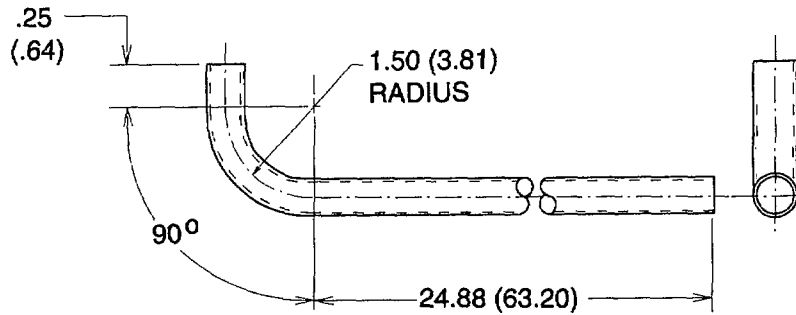

BLANK LENGTH 27.49 (69.82)

NOTE

1. FABRICATE FROM .625(1.58) O.D. X 0.035 (0.88) WALL ASTM B280 COPPER TUBING

Figure F-23. Tube, Outlet, Condenser Coil, Part Number 149K0075

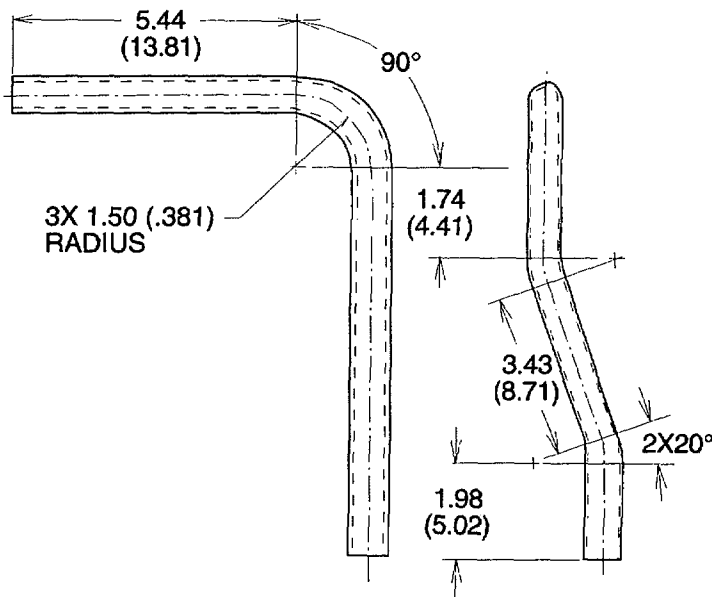

BLANK LENGTH 16.00 (40.64)

NOTE

1. FABRICATE FROM .625 (1.58) O.D. X 0.035 (0.088) WALL ASTM B280 COPPER TUBING

Figure F-24. Tube, Outlet, Discharge Pressure Regulator Valve, Part Number 149K0061

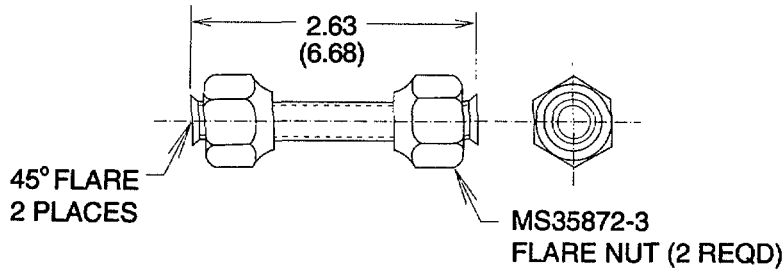

NOTE

1. FABRICATE FROM .375 (.952) O.D. X .030 (.076) WALL ASTM B280 COPPER TUBING

Figure F-25. Tube Assembly, Outlet Strainer, Part Number 149K0063-1/T

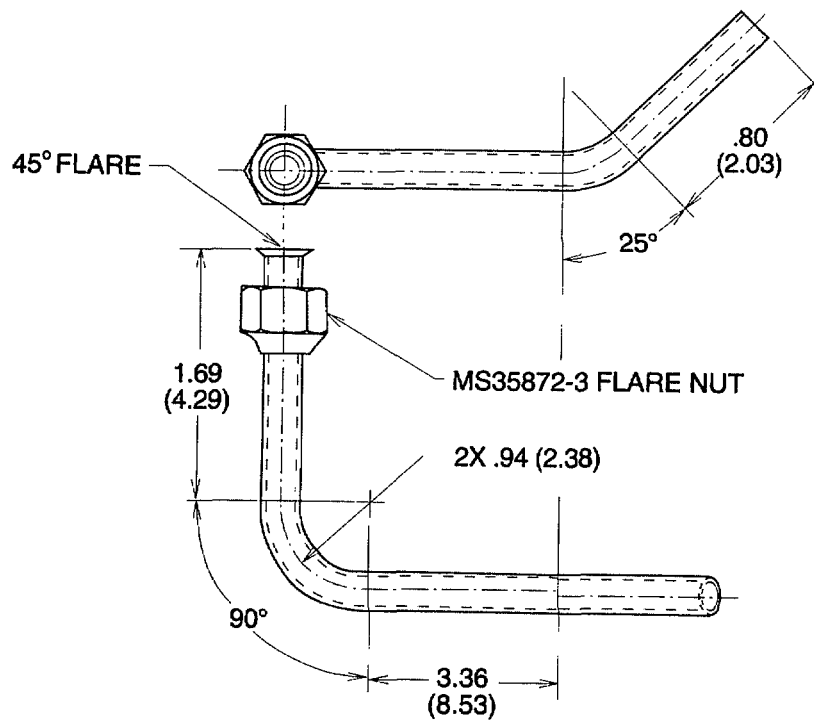

BLANK LENGTH 7.73 (19.63)

NOTE

1. FABRICATE FROM .375 (.95) O.D. X 0.030 (0.76) WALL ASTM B280 COPPER TUBING

Figure F-26. Tube Assembly, Outlet, Solenoid Valve, Part Number 149K0064-1/T

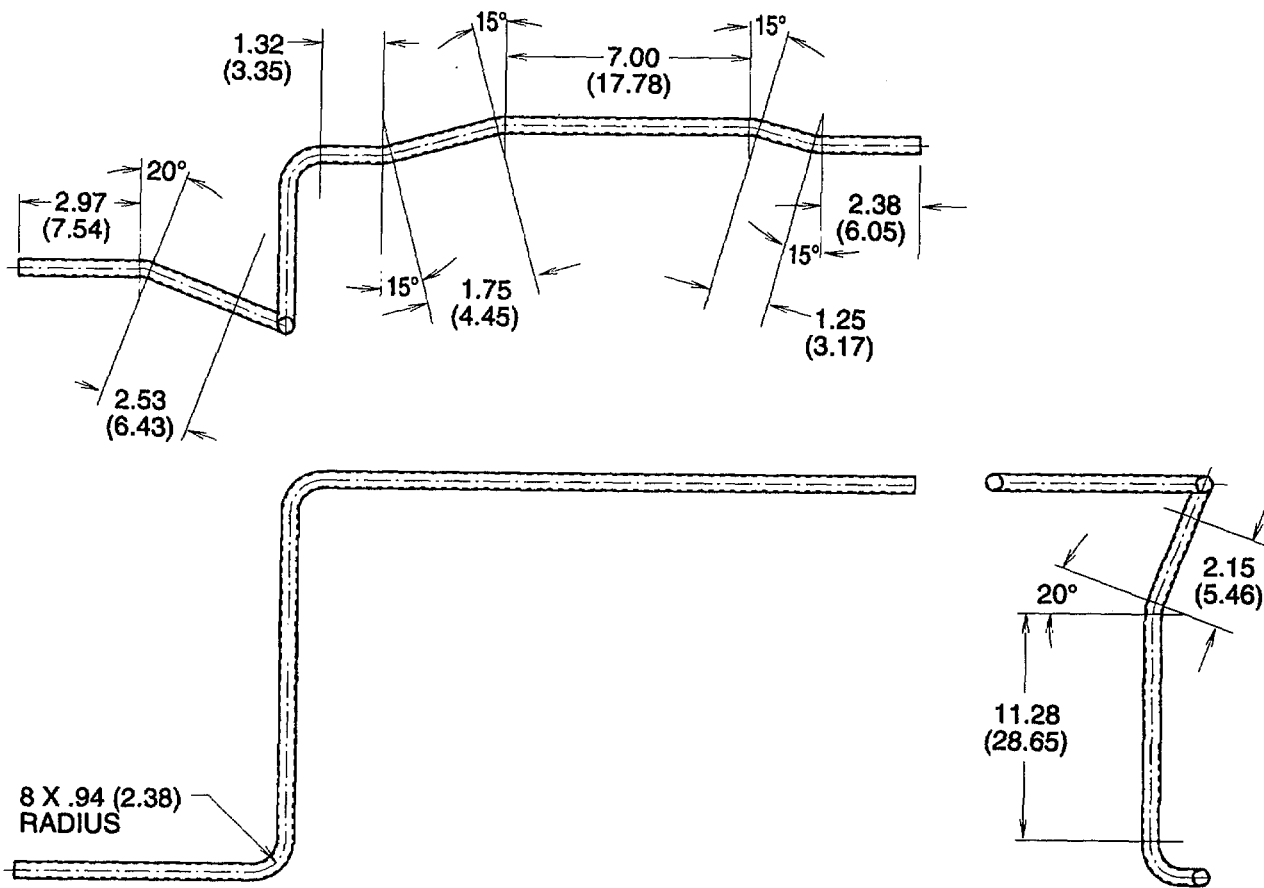

NOTE

- 1. FABRICATE FROM .375 (.952) O.D. X 0.030 (0.076) WALL ASTM B280 COPPER TUBING

BLANK LENGTH 37.23 (94.56)

Figure F-27. Tube, Inlet, Shut-off Valve, Part Number 149K0065

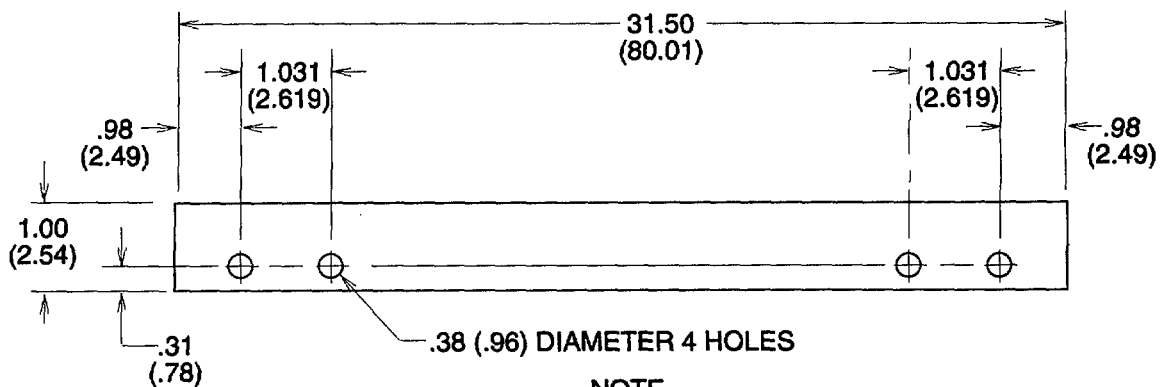

NOTE

- 1. FABRICATE FROM ASTM D1056-2A2C2F2 0.125 (0.318) THICK RUBBER GASKET

Figure F-28. Gasket, Cover, Control Box, Part Number 149K0072-1

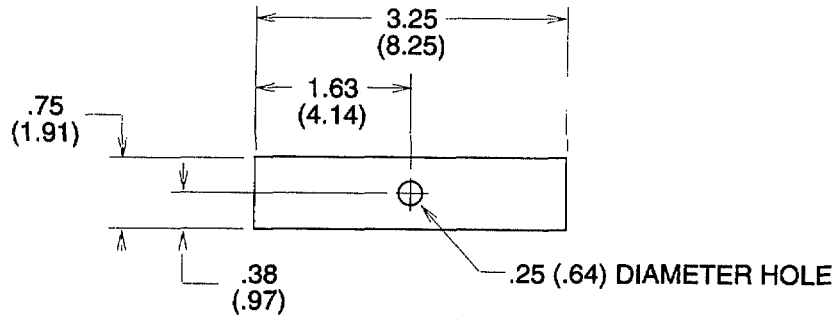

NOTE
 1. FABRICATE FROM ASTM D1056-2A2C2F2
 0.125 (0.318) THICK RUBBER GASKET

Figure F-29. Gasket, Circuit Breaker Panel, Part Number 151K0031

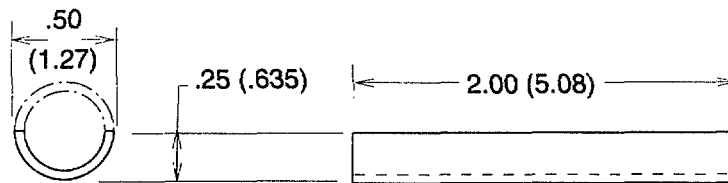

NOTE
 1. FABRICATE FROM 0.50 (1.27) X .032 (.0812)
 WALL ASTM B280 COPPER TUBING

Figure F-30. Contact Cradle, Sensing Bulb, Part Number 152K0194

APPENDIX G

MANDATORY REPLACEMENT PARTS

Item Number	Nomenclature	Part Number	
1	Lock Washer	500K1950-3	(94833)
2	Seal	020-0844-01	(14569)
3	Lock Washer	500K1950-2	(94833)
4	Terminal Mounting Plate Gasket	503-0346-01	(14569)
5	Teflon Seal	24591	(97765)
6	Lock Washer	500K1950-1	(94833)
7	Lock Washer	500K1950-5	(94833)
8	Self Locking Nut	500K1927-1	(94833)
9	Self Locking Nut	500K1927-9	(96906)
10	Cotter Pin	MS24665-351	(96906)
11	Self Locking Nut	52054-9	(94833)
12	Self Locking Nut	500K1927-3	(94833)
13	Lock Washer	500K1950-4	(94833)
14	Self Locking Nut	500K1927-2	(94833)
15	Self Locking Nut	500K1927-5	(94833)
16	Lock Washer	500K1950-6	(94833)
17	Self Locking Nut	500K1927-6	(94833)
18	Oil Pump Gasket	020-0732-00	(14569)
19	Locknut	101-0006-00	(14569)
20	Gasket	020-0012-11	(14569)
21	Gasket	020-0012-09	(14569)
22	Gasket	020-0756-00	(14569)

Item Number	Nomenclature	Part Number	
23	Gasket	020-0757-04	(14569)
24	Sight Glass	570-0020-00	(14569)
25	Self Locking Nut	500K1927-4	(94833)
26	Fused Cluster Terminal	521-0018-00	(14569)
27	Fused Cluster Seal	020-0844-00	(14569)
28	Lock Washer	102-0010-11	(14569)
29	Lock Washer	102-0010-08	(14569)

ALPHABETICAL INDEX

A

AC Motor B2 Testing and Replacement 4-41
 Access Panel Replacement 4-15
 Accumulator Replacement 5-23
 Administrative Storage 4-54
 Air Handling System 1-15
 Assembly and Preparation for Use 2-4

B

Barrel Bolts Replacement 4-13
 Brazing/Debraze Procedure 5-9

C

Charging the Refrigerant System 5-12
 Circuit Breaker CB1 Testing and Replacement 4-21
 Circuit Breaker Cover Repair 5-2
 Cleaning 3-4
 Coil Guard Front Panel Replacement 4-17
 Common Tools and Equipment 4-1
 Compound Gage (Suction Pressure) Replacement 5-31
 Compressor B1 Testing, Repair, and Replacement 5-36
 Condenser Coil Replacement 5-18
 Condenser Fan Replacement 4-42
 Condenser Frame Repair 6-2
 Contactor K2 Testing and Replacement 4-26
 Control Box Assembly Replacement 4-19
 Control Box Cover Repair and Replacement 5-42
 Control Panel Repair 5-3
 Control Relays K3 and K4 Testing and Replacement 4-27
 Corrosion Prevention and Control 1-9
 Cover Panel (Coil Guard Rear) Replacement 4-16

D

Decals and Instruction Plates 2-8
 Defrost Termination Thermostat S4 Testing and Replacement 4-51
 Dehydrator Replacement 5-14
 Destruction of Army Material To Prevent Enemy Use 1-3
 Differential Oil Pressure Switch S5 Replacement 5-29
 Discharging the Refrigerant System 5-7
 Dual Pressure Control Switch S2 Replacement. ... 5-30
 Dummy Stowage Connector and Cover Replacement 4-34

E

Electrical System 1-13
 Equipment Characteristics, Capabilities and Features 1-10
 Equipment Data 1-12
 Evacuating the Refrigerant System 5-11
 Evaporator Coil Replacement 5-35
 Evaporator Fan Replacement 4-43
 Expansion Valve Replacement..... 5-34

F

Fan Drive Shaft Replacement 5-4
 Fault Controls and Indicators 2-2
 Flange Bearing (Condenser Fan) Replacement. 4-46
 Flange Bearing (Evaporator Fan) Replacement. 4-45
 Frame Repair 5-43
 Front Bottom Door Replacement 5-40
 Front Top Door Replacement..... 5-41
 Fuses F1 and F2 Testing and Replacement 4-24

G

General 2-3, 3-3, 4-10, 6-1
 Grease Fitting Extension Replacement 4-50
 Ground Strap (Compressor) Replacement. 4-52
 Ground Strap (Control Box Assembly) Replacement 4-33
 Ground Strap (Motor) Replacement 4-40

H

Heat Exchanger Replacement 5-33
 Heat Shield Gaskets Replacement 4-53
 Hourmeter M1 Testing and Replacement 4-28

I

Installation Instructions 4-6
 Isolation Valves Replacement 5-16

L

Lamp DS1 Assembly Testing and Replacement..... 4-23
 Leak Testing the Refrigerant System..... 5-10
 Left and Right Side Door Replacement..... 5-39
 Location and Description of Major
 Components 1-11
 Long Term Storage or Shipment 4-56
 Lubrication 3-1, 4-9

M

Maintenance Forms, Records and Reports 1-2
 Mandatory Replacement Parts ... 4-11
 Metal Hose Assembly (Discharge)
 Replacement. 5-20
 Metal Hose Assembly (Suction) Replacement. 5-22
 Motor Starter K1 Testing, Repair, and
 Replacement..... 4-25

N

NBC Decontamination Procedures 2-10

O

Official Nomenclature, Names and
 Designations 1-6
 Operating Controls and Indicators.. 2-1
 Operation Under Inclement Weather 2-9
 Operator Checks 2-6

P

Plates (Data) Replacement 5-38
 Power Distribution Block TB2 Replacement 4-36
 Preliminary Adjustment of Equipment 4-8
 Preliminary Servicing of Equipment 4-7
 Preparation For Storage or Shipment 1-4
 Pressure Gage (Discharge Pressure) Replacement 5-32
 Pressure Regulator Valve (Discharge)
 Replacement 5-19
 Pressure Regulator Valve (Suction)
 Replacement 5-21
 Pulley (Sheave and Bushing) Replacement..... 4-44
 Pulley Replacement 4-39
 Pump Down Refrigeration Unit 4-55
 Purging the Refrigerant System 5-8
 Push Switches S6 and S7 Testing and
 Replacement..... 4-37

Q

Quality Assurance 1-5

R

Receiver and Fusible Plug Replacement. 5-17
 Refrigerant System Pressure Check 5-13
 Refrigeration System..... 1-14
 Refrigeration System Repairs 5-5
 Remote Bulb Thermostat S3 Testing and
 Replacement 4-31
 Repair Parts 4-3
 Repeat Cycle Timer TM1 Testing and
 Replacement 4-30
 Reporting Equipment Improvement
 Recommendations (EIR)..... 1-7
 Reset Button Replacement 4-35
 Resistor R1 Assembly Testing and
 Replacement 4-22

S

Scope 1-1
 Service Manifold Installation..... 5-6
 Service Upon Receipt of Material 4-5
 Shutdown Procedures 2-7
 Sight Indicator Replacement 5-28
 Site and Shelter Requirements 4-4
 Solenoid Valve L1 (Liquid Line) Replacement..... 5-24
 Solenoid Valve L1 (Liquid Line) Testing and
 Repair..... 4-47
 Solenoid Valve L2 (Defrost Line) Replacement 5-25
 Solenoid Valve L2 (Defrost Line) Testing and
 Repair 4-48
 Special Tools, TMDE, and Support Equipment 4-2
 Startup Procedures 2-5
 Stop Valve (Defrost Line) Replacement..... 5-27
 Stop Valve (Liquid Line) Replacement..... 5-26
 Strainer Replacement 5-15

T

Terminal Board Tb1 Replacement 4-32
 Thermometer Testing and Replacement 4-49
 Toggle Switch S1 Testing and Replacement..... 4-29
 Top Access Panel Replacement..... 4-14
 Troubleshooting 3-2, 4-12, 5-1
 Tubing and Fittings Testing, Repair, and
 Replacement 5-37

U

Unit Mounting Bolt Assembly Replacement 4-18

V

V-Belt Replacement and Adjustment 4-38

W

Warranty Information 1-8
Wires, Cables, and Harnesses Testing, Repair,
and Replacement 4-20

By Order of the Secretary of the Army:

Official

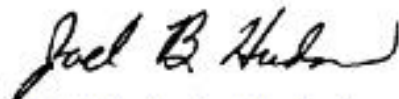

*Administrative Assistant to the
Secretary of the Army*
02020

DENNIS J REIMER
General, United States Army
Chief of Staff

DISTRIBUTION:

To be distributed in accordance with DA Form 12-25-E, block no. 6304, requirements for TM 9-4110-254-14.

These are the instructions for sending an electronic 2028

The following format must be used if submitting an electronic 2028. The subject line must be exactly the same and all fields must be included; however only the following fields are mandatory: 1, 3, 4, 5, 6, 7, 8, 9, 10, 13, 15, 16, 17, and 27.

From: Whomever" <whomever@avma27.army.mil>
To: mpmt%avma28@st-louis-emh7 army.mil

Subject: DA Form 2028

1. **From:** Joe Smith
2. **Unit:** home
3. **Address:** 4300 Park
4. **City:** Hometown
5. **St:** MO
6. **Zip:** 77777
7. **Date Sent:** 19-OCT-93
8. **Pub no:** 55-2840-229-23
9. **Pub Title:** TM
10. **Publication Date:** 04-JUL-85
11. **Change Number:** 7
12. **Submitter Rank:** MSG
13. **Submitter FName:** Joe
14. **Submitter MName:** T
15. **Submitter LName:** Smith
16. **Submitter Phone:** 123-123-1234
17. **Problem:** 1
18. **Page:** 2
19. **Paragraph:** 3
20. **Line:** 4
21. **NSN:** 5
22. **Reference:** 6
23. **Figure:** 7
24. **Table:** 8
25. **Item:** 9
26. **Total:** 123
27. **Text:**

This is the text for the problem below line 27.

RECOMMENDED CHANGES TO EQUIPMENT TECHNICAL PUBLICATIONS



THEN...JOT DOWN THE
DOPE ABOUT IT ON THIS FORM.
CAREFULLY TEAR IT OUT, FOLD IT
AND DROP IT IN THE MAIL.

SOMETHING WRONG WITH PUBLICATION

FROM: (PRINT YOUR UNIT'S COMPLETE ADDRESS)

DATE SENT

PUBLICATION NUMBER

PUBLICATION DATE

PUBLICATION TITLE

BE EXACT PIN-POINT WHERE IT IS

PAGE
NO.

PARA-
GRAPH

FIGURE
NO.

TABLE
NO.

IN THIS SPACE, TELL WHAT IS WRONG
AND WHAT SHOULD BE DONE ABOUT IT.

TEAR ALONG PERFORATED LINE

PRINTED NAME, GRADE OR TITLE AND TELEPHONE NUMBER

SIGN HERE

The Metric System and Equivalents

Linear Measure

1 centimeter = 10 millimeters = .39 inch
 1 decimeter = 10 centimeters = 3.94 inches
 1 meter = 10 decimeters = 39.37 inches
 1 dekameter = 10 meters = 32.8 feet
 1 hectometer = 10 dekameters = 328.08 feet
 1 kilometer = 10 hectometers = 3,280.8 feet

Weights

1 centigram = 10 milligrams = .15 grain
 1 decigram = 10 centigrams = 1.54 grains
 1 gram = 10 decigram = .035 ounce
 1 decagram = 10 grams = .35 ounce
 1 hectogram = 10 decagrams = 3.52 ounces
 1 kilogram = 10 hectograms = 2.2 pounds
 1 quintal = 100 kilograms = 220.46 pounds
 1 metric ton = 10 quintals = 1.1 short tons

Liquid Measure

1 centiliter = 10 milliliters = .34 fl. ounce
 1 deciliter = 10 centiliters = 3.38 fl. ounces
 1 liter = 10 deciliters = 33.81 fl. ounces
 1 dekaliter = 10 liters = 2.64 gallons
 1 hectoliter = 10 dekaliters = 26.42 gallons
 1 kiloliter = 10 hectoliters = 264.18 gallons

Square Measure

1 sq. centimeter = 100 sq. millimeters = .155 sq. inch
 1 sq. decimeter = 100 sq. centimeters = 15.5 sq. inches
 1 sq. meter (centare) = 100 sq. decimeters = 10.76 sq. feet
 1 sq. dekameter (are) = 100 sq. meters = 1,076.4 sq. feet
 1 sq. hectometer (hectare) = 100 sq. dekameters = 2.47 acres
 1 sq. kilometer = 100 sq. hectometers = .386 sq. mile

Cubic Measure

1 cu. centimeter = 1000 cu. millimeters = .06 cu. inch
 1 cu. decimeter = 1000 cu. centimeters = 61.02 cu. inches
 1 cu. meter = 1000 cu. decimeters = 35.31 cu. feet

Approximate Conversion Factors

To change	To	Multiply by	To change	To	Multiply by
inches	centimeters	2.540	ounce-inches	Newton-meters	.007062
feet	meters	.305	centimeters	inches	.394
yards	meters	.914	meters	feet	3.280
miles	kilometers	1.609	meters	yards	1.094
square inches	square centimeters	6.451	kilometers	miles	.621
square feet	square meters	.093	square centimeters	square inches	.155
square yards	square meters	.836	square meters	square feet	10.764
square miles	square kilometers	2.590	square meters	square yards	1.196
acres	square hectometers	.405	square kilometers	square miles	.386
cubic feet	cubic meters	.028	square hectometers	acres	2.471
cubic yards	cubic meters	.765	cubic meters	cubic feet	35.315
fluid ounces	milliliters	29.573	cubic meters	cubic yards	1.308
pints	liters	.473	milliliters	fluid ounces	.034
quarts	liters	.946	liters	pints	2.113
gallons	liters	3.785	liters	quarts	1.057
ounces	grams	28.349	liters	gallons	.264
pounds	kilograms	.454	grams	ounces	.035
short tons	metric tons	.907	kilograms	pounds	2.205
pound-feet	Newton-meters	1.356	metric tons	short tons	1.102
pound-inches	Newton-meters	.11296			

Temperature (Exact)

°F	Fahrenheit temperature	5/9 (after subtracting 32)	Celsius temperature	°C
----	------------------------	----------------------------	---------------------	----

PIN: 074736-000